

PLEASE CHECK WWW.MOLEX.COM FOR LATEST PART INFORMATION

Part Number: **0191640306**
Status: **Active**
Description: Perma-Seal™ Ring Tongue Terminal for 18-22 AWG Wire, Stud Size 10, Mylar Tape Carrier

Documents:

[Drawing \(PDF\)](#) [RoHS Certificate of Compliance \(PDF\)](#)

Agency Certification

CSA LR18689
 UL E32244

General

Product Family Ring and Spade Terminals
 Series 19164
 Crimp Quality Equipment Yes
 Mil-Spec N/A
 Product Name Perma-Seal™
 Type Ring

Physical

Barrel Type Closed
 Flammability 94V-2
 Insulation NiAc™
 Material - Plating Mating Tin
 Packaging Type Adhesive Tape on Reel
 Stud Size 10 (M5)
 Wire Insulation Diameter 5.97mm (.235")
 Wire Size AWG 18, 20, 22
 Wire Size mm² 0.38 - 0.96

Material Info

Old Part Number SA-221-10T

Reference - Drawing Numbers

Sales Drawing SD-19164-006



EU RoHS

ELV and RoHS Compliant
REACH SVHC
 Not Reviewed
Halogen-Free Status
Not Reviewed

China RoHS



Need more information on product environmental compliance?

Email productcompliance@molex.com
 For a multiple part number RoHS Certificate of Compliance, [click here](#)

Please visit the [Contact Us](#) section for any non-product compliance questions.

Search Parts in this Series

[19164Series](#)

Application Tooling | [FAQ](#)

Tooling specifications and manuals are found by selecting the products below. Crimp Height Specifications are then contained in the Application Tooling Specification document.

Global

Description	Product #
Power Crimp Tool Head for Prema-Seal™ Terminals 10-22 AWG	0640057400
ATP Perishable Tool Kit Used in ATP Presses that Process 18-22 AWG Product on Tape	0198082009
Hand Crimp Tool, UL Approved	0640017400

This document was generated on 04/14/2010

PLEASE CHECK WWW.MOLEX.COM FOR LATEST PART INFORMATION

	10	9	8	7	6	5	4	3	2	1	
F	MATERIAL NUMBER	ENGINEERING NUMBER	MATERIAL NUMBER ON TAPE	ENGINEERING NUMBER ON TAPE	STUD SIZE	HOLE "S" ± 0.005 ± 0.03	"D" MAX	"H" ± 0.10 ± 0.25	"L" MAX	"T" REF	ID MIN
	191640085	SA-221-06	---	---	#6	$\varnothing .146/3.71$	$\varnothing .32/8.1$	---	1.46/37.1	.028/0.71	.064/1.63
	191640086	SA-221-08	191640419	SA-221-08T	#8	$\varnothing .173/4.39$	$\varnothing .32/8.1$.534/13.56	1.46/37.1	.028/0.71	.064/1.63
	191640003	SA-221-10	191640306	SA-221-10T	#10	$\varnothing .198/5.03$	$\varnothing .32/8.1$.534/13.56	1.46/37.1	.028/0.71	.064/1.63
	191640004	SA-222-14	191640844	SA-222-14T	1/4	$\varnothing .265/6.73$	$\varnothing .48/12.2$.340/8.65	1.66/42.2	.028/0.71	.055/1.40
	191640005	SA-226-38	191640845	SA-226-38T	3/8	$\varnothing .390/9.91$	$\varnothing .54/13.7$.328/8.33	1.95/49.5	.032/0.81	.055/1.40

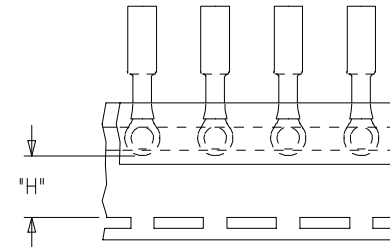
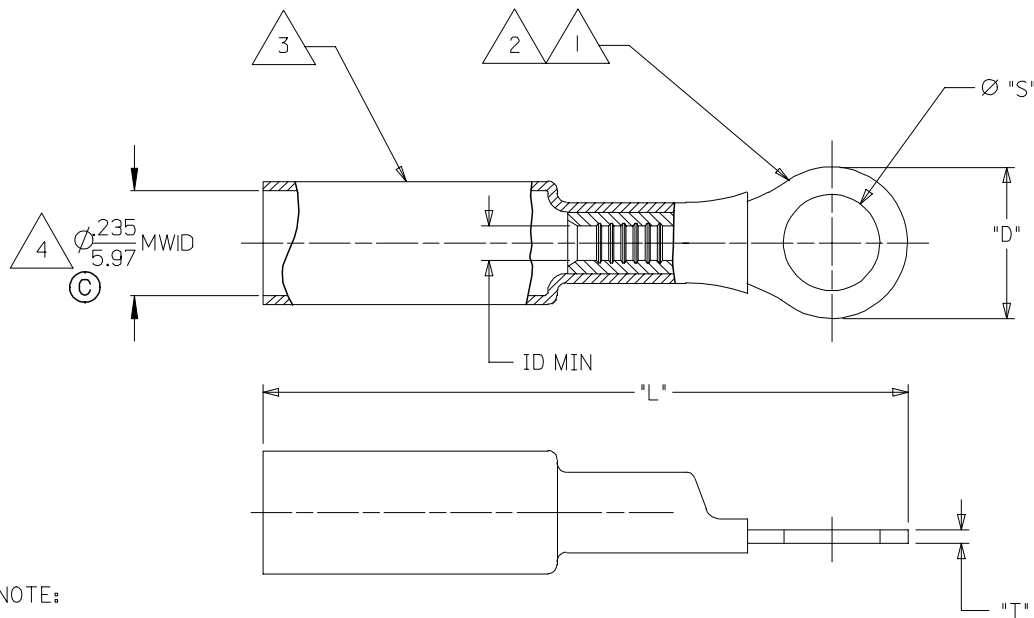

PARTS ON TAPE

SALES DRAWING

NOTE:

- 1. TERMINAL MATERIAL: COPPER ALLOY
- 2. FINISH: ELECTRO TIN PLATE.
- 3. INSULATION MATERIAL: HEAT SHRINKABLE TUBING WITH HOTMELT ADHESIVE INNER LINER. COLOR: RED.
- 4. MWID = MAXIMUM WIRE INSULATION DIAMETER.

CHANGED MWID EC NO: ETC2006-0154 DRWN:NASAYDEH 2005/12/21 CHKD: ILOMASTRO 2005/12/21 APPR: JPAMLIK 2005/12/21	QUALITY SYMBOLS	GENERAL TOLERANCES (UNLESS SPECIFIED)	DIMENSION STYLE IN/MM	SCALE ---	DESIGN UNITS INCH	THIRD ANGLE PROJECTION																											
	$\nabla=0$ $\nabla=0$	<table border="1"> <thead> <tr> <th></th> <th>mm</th> <th>INCH</th> </tr> </thead> <tbody> <tr> <td>4 PLACES</td> <td>\pm---</td> <td>\pm---</td> </tr> <tr> <td>3 PLACES</td> <td>± 0.13</td> <td>$\pm .005$</td> </tr> <tr> <td>2 PLACES</td> <td>± 0.25</td> <td>$\pm .010$</td> </tr> <tr> <td>1 PLACE</td> <td>\pm---</td> <td>\pm---</td> </tr> </tbody> </table>		mm	INCH	4 PLACES	\pm ---	\pm ---	3 PLACES	± 0.13	$\pm .005$	2 PLACES	± 0.25	$\pm .010$	1 PLACE	\pm ---	\pm ---	<table border="1"> <thead> <tr> <th>DRAWN BY</th> <th>DATE</th> </tr> </thead> <tbody> <tr> <td>BENDERLE</td> <td>2005/5/14</td> </tr> <tr> <th>CHECKED BY</th> <th>DATE</th> </tr> <tr> <td>HBEITZEL</td> <td>2005/5/14</td> </tr> <tr> <th>APPROVED BY</th> <th>DATE</th> </tr> <tr> <td>RDEROSS</td> <td>2005/5/14</td> </tr> </tbody> </table>	DRAWN BY	DATE	BENDERLE	2005/5/14	CHECKED BY	DATE	HBEITZEL	2005/5/14	APPROVED BY	DATE	RDEROSS	2005/5/14	TITLE		
		mm	INCH																														
	4 PLACES	\pm ---	\pm ---																														
3 PLACES	± 0.13	$\pm .005$																															
2 PLACES	± 0.25	$\pm .010$																															
1 PLACE	\pm ---	\pm ---																															
DRAWN BY	DATE																																
BENDERLE	2005/5/14																																
CHECKED BY	DATE																																
HBEITZEL	2005/5/14																																
APPROVED BY	DATE																																
RDEROSS	2005/5/14																																
	<table border="1"> <thead> <tr> <th>MATERIAL NO.</th> <th>DOCUMENT NO.</th> <th>SHEET NO.</th> </tr> </thead> <tbody> <tr> <td>SEE CHART</td> <td>SD-19164-006</td> <td>1 OF 1</td> </tr> </tbody> </table>	MATERIAL NO.	DOCUMENT NO.	SHEET NO.	SEE CHART	SD-19164-006	1 OF 1	RING TONGUE TERMINAL PERMA-SEAL NIAC 22-18 AWG MOLEX INCORPORATED																									
MATERIAL NO.	DOCUMENT NO.	SHEET NO.																															
SEE CHART	SD-19164-006	1 OF 1																															
	DRAFT WHERE APPLICABLE MUST REMAIN WITHIN DIMENSIONS					THIS DRAWING CONTAINS INFORMATION THAT IS PROPRIETARY TO MOLEX INCORPORATED AND SHOULD NOT BE USED WITHOUT WRITTEN PERMISSION																											