

IN74LV620

OCTAL 3-STATE INVERTING BUS TRANSCEIVER

Microcircuits IN74LV620 are pin-to-pin compatible with microcircuits of series 74ALS620, 74HC620, 74HCT620. Input voltage levels are compatible with standard C-MOS levels

Features:

Output voltage levels are compatible with input levels C-MOS, N-MOS and TTL microcircuits.

Supply voltage range from 1.2 to 3.6 V.

Maximum input current: 1.0 mA; 0.1 mA at T = 25 °C.

Consumption current 8 mA.

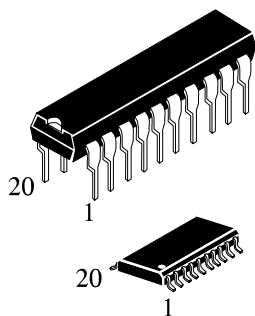

N SUFFIX
PLASTIC

DW SUFFIX
SOIC

ORDERING INFORMATION

IN74LV620N	Plastic
IN74LV620D	SOIC

T_A = -40° to 125° C for all packages

Block diagram

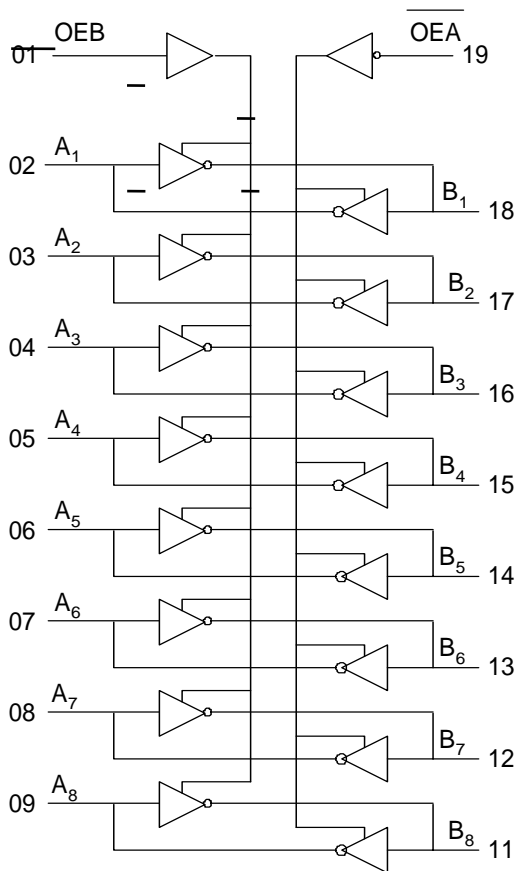

Truth table

Inputs		Inputs/Outputs	
OEB	OEA	A	B
L	L	A=B	input
H	H	input	B=A
L	H	Z	Z
H	H	A=B	B=A

Pinout

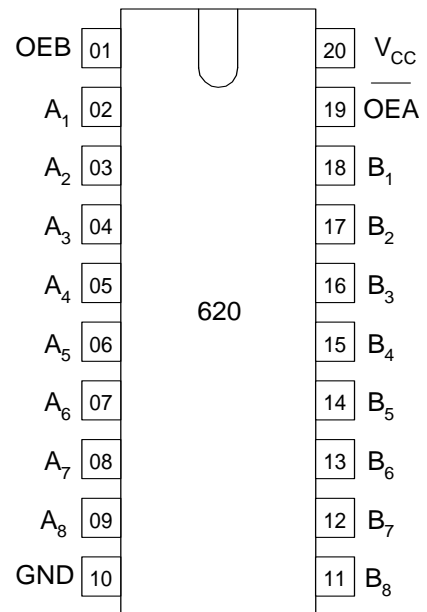

Absolute maximum ratings*

Symbol	Parameter	Value	Unit
V_{CC}	Supply voltage	from -0.5 to +5.0	V
I_{IK}^{*1}	Input diode current	± 20	mA
I_{OK}^{*2}	Output diode current	± 50	mA
I_O^{*3}	Output current source-drain	± 35	mA
I_{CC}	Supply output current	± 70	mA
I_{GND}	Common output current	± 70	mA
P_D	Dissipation power at free air change, Plastic DIP SOIC * ⁴	750 500	mW
Tstg	Storage temperature	from -65 to +150	°C
T_L		260	°C

* Under absolute maximum conditions operation of microcircuits is not guaranteed. Operation under maximum conditions is guaranteed.
^{*1} If $V_I < -0.5V$ or $V_I > V_{CC} + 0.5 V$.
^{*2} If $V_O < -0.5V$ or $V_O > V_{CC} + 0.5 V$.
^{*3} If $-0.5V < V_O < V_{CC} + 0.5 V$.
^{*4} Under operation in the temperature range from 65°C to 125°C value of dissipation power drops down - to 10 mW/°C for Plastic DIP
- to 7 mW/°C for SOIC

Maximum conditions

Symbol	Parameter	Min	Max	Unit
V_{CC}	Supply voltage	1.2	3.6	V
V_{IN}	Input voltage	0	V_{CC}	V
V_{OUT}	Output voltage	0	V_{CC}	V
T_A	Operation temperature. For all packages	-40	125	°C
t_{LH}, t_{HL}	Period of signal rise and fall edges (Figure 1)			ns
	$V_{CC}=1.2 B$	0	1000	
	$V_{CC}=2.0 B$		700	
	$V_{CC}=3.0 B$		500	
	$V_{CC}=3.6 B$		400	

DC electrical characteristics

Symbol	Parameter	Test conditions	V _{CC} , V	Value						Unit
				25°C		From -40°C to 85°C		From -40°C to 125°C		
				min	max	min	max	min	max	
V _{IH}	High input voltage	V _O = V _{CC} -0.1 V	1.2	0.9	-	0.9	-	0.9	-	V
			2.0	1.4	-	1.4	-	1.4	-	
			3.0	2.1	-	2.1	-	2.1	-	
			3.6	2.5	-	2.5	-	2.5	-	
V _{IL}	Low input voltage	V _O = 0.1 V	1.2	-	0.3	-	0.3	-	0.3	V
			2.0	-	0.6	-	0.6	-	0.6	
			3.0	-	0.9	-	0.9	-	0.9	
			3.6	-	1.1	-	1.1	-	1.1	
V _{OH}	High output voltage	V _I = V _{IH} or V _{IL} I _O = -50 mA	1.2	1.11	-	1.1	-	1.1	-	V
		2.0	1.91	-	1.9	-	1.9	-		
		V _I = V _{IH} or V _{IL} I _O = -8 mA	3.0	2.91	-	2.9	-	2.9	-	V
		3.6	3.51	-	3.5	-	3.5	-		
V _{OL}	Low output voltage	V _I = V _{IH} or V _{IL} I _O = 50 mA	1.2	-	0.09	-	0.1	-	0.1	V
			2.0	-	0.09	-	0.1	-	0.1	
			3.0	-	0.09	-	0.1	-	0.1	
			3.6	-	0.09	-	0.1	-	0.1	
		V _I = V _{IH} or V _{IL} I _O = 8 mA	3.0	-	0.33	-	0.4	-	0.5	V
I _I	Input current	V _I = V _{CC} or 0 V	3.6	-	±0.1	-	±1.0	-	±1.0	uA
I _{OZ}	Output current in «off» state	Outputs in the third state V _I = V _{IL} or V _{IH} V _O = V _{CC} or 0 V	3.6	-	±0.5	-	±5	-	±10	uA
I _{CC}	Consumption current	V _I = V _{CC} or 0 V I _O = 0 mA	3.6	-	8.0	-	80	-	160	uA

AC electrical characteristics ($C_L=50$ pF, $t_{LH} = t_{HL} = 6.0$ ns)

Sym-bol	Parameter	Test conditions	V_{CC} , V	Value						Unit
				25°C		From -40°C to 85°C		From -40°C to 125°C		
				min	max	min	max	min	max	
t_{PHL} , t_{PLH} from A to B from B to A	Propagation delay time in «on» and «off» states	Fig.1	1.2	-	100	-	125	-	140	ns
			2.0	-	23	-	28	-	34	
			3.0	-	14	-	18	-	21	
t_{PHZ} t_{PLZ} from OE to Y	Propagation delay time when switching from high, low levels into «off» state	Fig.2	1.2	-	120	-	140	-	160	ns
			2.0	-	30	-	37	-	43	
			3.0	-	20	-	24	-	28	
t_{PZH} t_{PZL} from OE to Y	Propagation delay time when switching from «off» state into high, low levels	Fig.2	1.2	-	120	-	140	-	160	ns
			2.0	-	28	-	35	-	43	
			3.0	-	17	-	21	-	26	
t_{THL} , t_{TLH}	Transition time when switching on, off	Fig.1	1.2	-	60	-	75	-	90	ns
			2.0	-	16	-	20	-	24	
			3.0	-	10	-	13	-	15	
C_I	Input capacitance		3.0	-	7	-	-	-	-	pF
C_{PD}	Dynamic capacitance (for one channel)	$V_I = 0$ V or V_{CC}	3.0	-	50	-	-	-	-	

- Time diagram of control of AC characteristics t_{PLH} , t_{PHL}

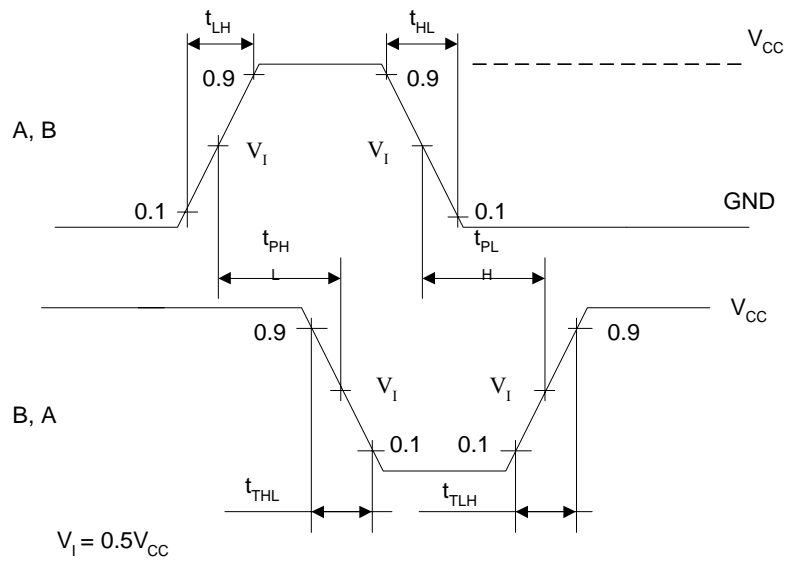

Fig.1

- Time diagram of control of AC characteristics t_{PLZ} , t_{PHZ} , t_{PZL} , t_{PZH}

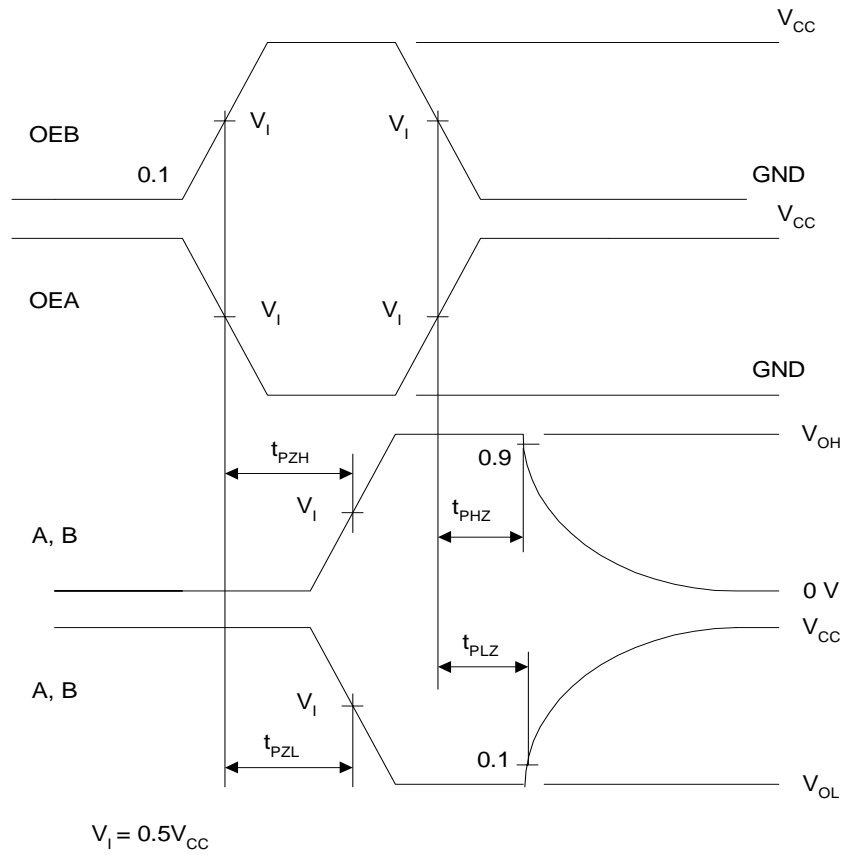
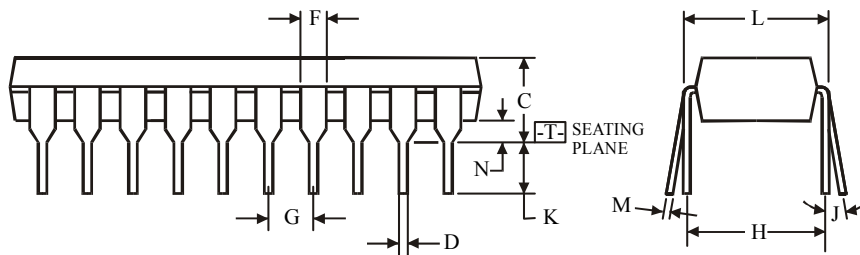
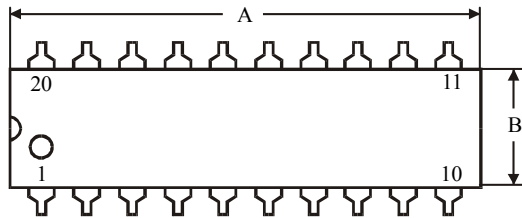
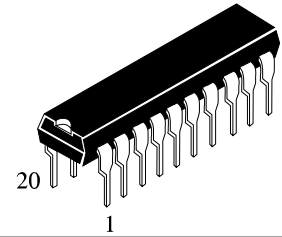

Fig.2

N SUFFIX PLASTIC DIP
(MS - 001AD)



$\oplus 0.25 (0.010) \text{M} \text{T}$

NOTES:

- Dimensions "A", "B" do not include mold flash or protrusions.
Maximum mold flash or protrusions 0.25 mm (0.010) per side.

Symbol	Dimension, mm	
	MIN	MAX
A	24.89	26.92
B	6.1	7.11
C		5.33
D	0.36	0.56
F	1.14	1.78
G	2.54	
H	7.62	
J	0°	10°
K	2.92	3.81
L	7.62	8.26
M	0.2	0.36
N	0.38	

D SUFFIX SOIC
(MS - 013AC)

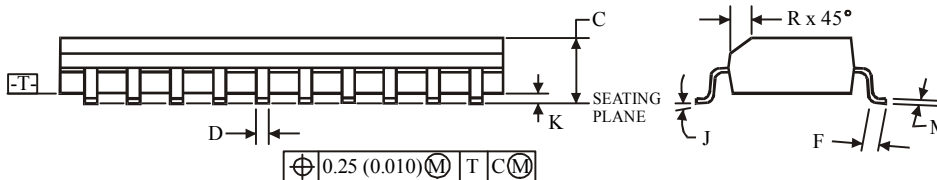
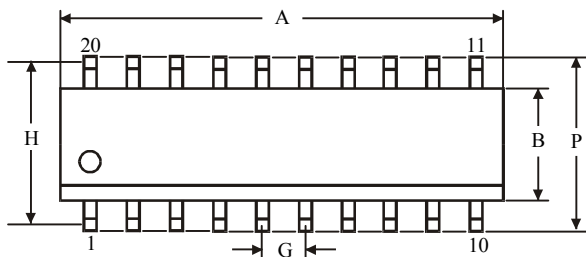
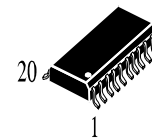

$\oplus 0.25 (0.010) \text{M} \text{T} \text{C} \text{M}$

NOTES:

- Dimensions A and B do not include mold flash or protrusion.
- Maximum mold flash or protrusion 0.15 mm (0.006) per side for A; for B - 0.25 mm (0.010) per side.

Symbol	Dimension, mm	
	MIN	MAX
A	12.6	13
B	7.4	7.6
C	2.35	2.65
D	0.33	0.51
F	0.4	1.27
G	1.27	
H	9.53	
J	0°	8°
K	0.1	0.3
M	0.23	0.32
P	10	10.65
R	0.25	0.75