

Silicon NPN Power Transistors

2SC2615

DESCRIPTION

- With TO-247 package
- High voltage,high speed

APPLICATIONS

- For high voltage,high speed and high power switching applications

PINNING

PIN	DESCRIPTION
1	Base
2	Collector;connected to mounting base
3	Emitter

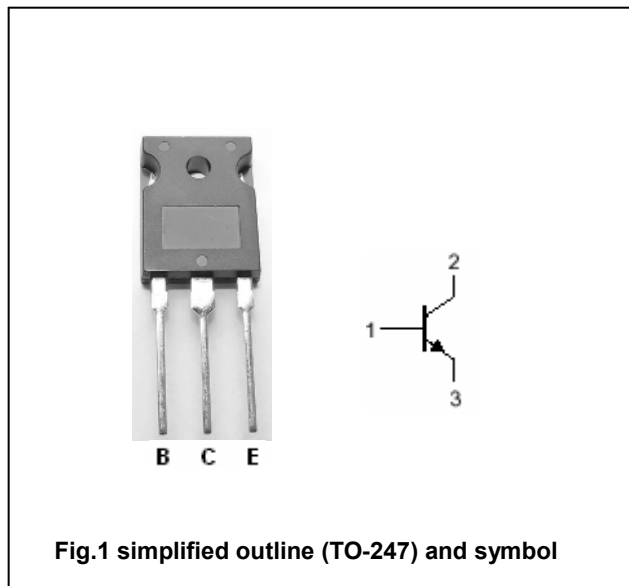

Absolute maximum ratings(Tc=25°C)

SYMBOL	PARAMETER	CONDITIONS	VALUE	UNIT
V <sub>CBO</sub>	Collector-base voltage	Open emitter	500	V
V <sub>CEO</sub>	Collector-emitter voltage	Open base	400	V
V <sub>EBO</sub>	Emitter-base voltage	Open collector	7	V
I <sub>C</sub>	Collector current (DC)		8	A
P <sub>C</sub>	Collector power dissipation	T <sub>C</sub> =25°C	80	W
T <sub>j</sub>	Junction temperature		150	°C
T <sub>stg</sub>	Storage temperature		-55~150	°C

## Silicon NPN Power Transistors

## 2SC2615

## CHARACTERISTICS

T<sub>j</sub>=25°C unless otherwise specified

SYMBOL	PARAMETER	CONDITIONS	MIN	TYP.	MAX	UNIT
V <sub>CEO(SUS)</sub>	Collector-emitter sustaining voltage	I <sub>C</sub> =0.2A; I <sub>B</sub> =0	400			V
V <sub>(BR)EBO</sub>	Emitter-base breakdown voltage	I <sub>E</sub> =10mA; I <sub>C</sub> =0	7			V
V <sub>CEsat</sub>	Collector-emitter saturation voltage	I <sub>C</sub> =4A; I <sub>B</sub> =0.8A			1.0	V
V <sub>BEsat</sub>	Base-emitter saturation voltage	I <sub>C</sub> =4A; I <sub>B</sub> =0.8A			1.5	V
I <sub>CBO</sub>	Collector cut-off current	V <sub>CB</sub> =400V; I <sub>E</sub> =0			0.1	mA
I <sub>EBO</sub>	Emitter cut-off current	V <sub>EB</sub> =5V; I <sub>C</sub> =0			0.1	mA
h <sub>FE-1</sub>	DC current gain	I <sub>C</sub> =4A; V <sub>CE</sub> =5V	15			
h <sub>FE-2</sub>	DC current gain	I <sub>C</sub> =8A; V <sub>CE</sub> =5V	7			

Silicon NPN Power Transistors

2SC2615

PACKAGE OUTLINE

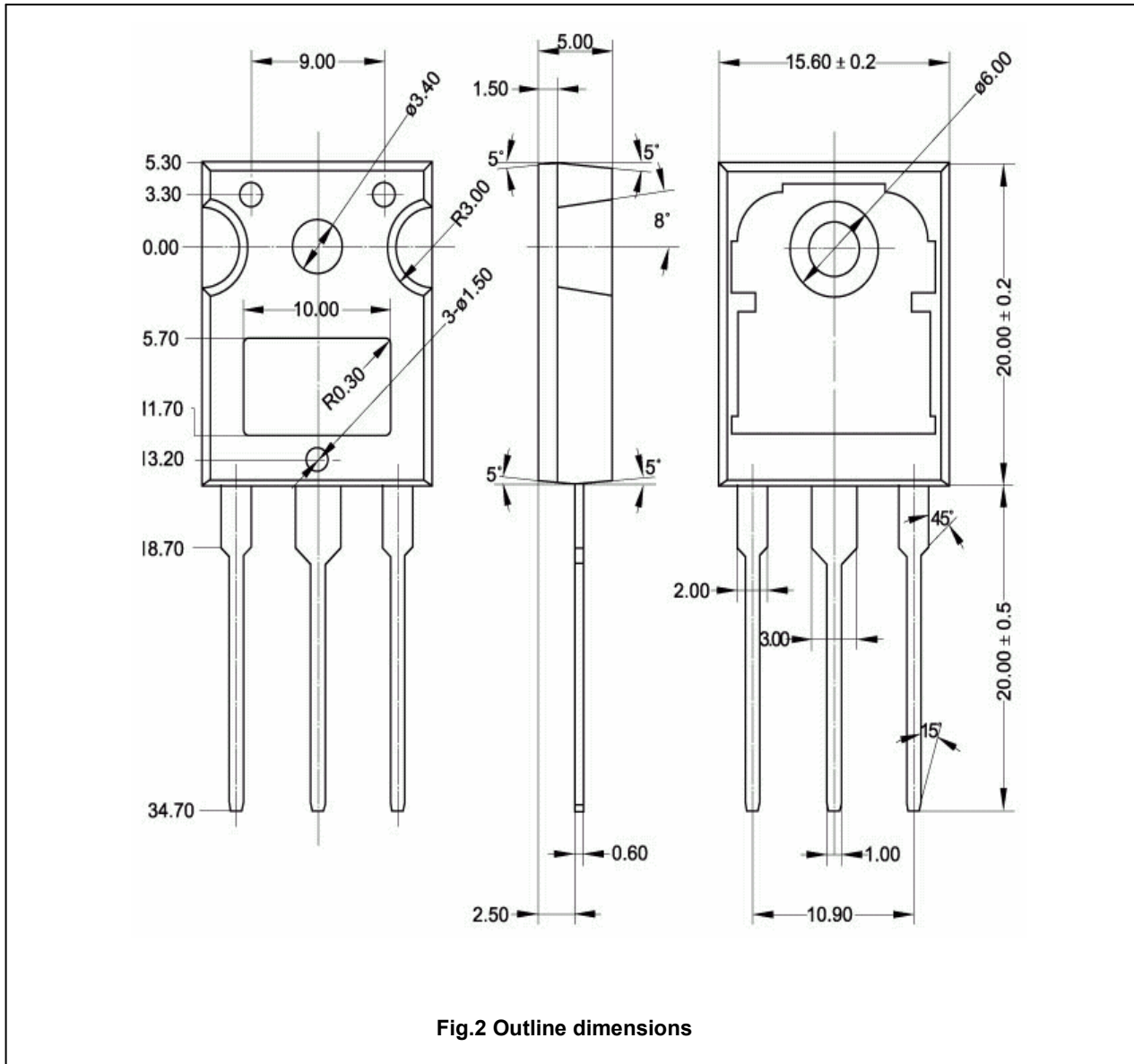

Fig.2 Outline dimensions