

Silicon NPN Power Transistors

BD809

DESCRIPTION

- With TO-220C package
- Complement to type BD810
- DC current gain
: $h_{FE} = 30$ (Min) @ $I_C = 2.0$ Adc

APPLICATIONS

- Designed for use in high power audio amplifiers utilizing complementary or quasi complementary circuits.

PINNING

PIN	DESCRIPTION
1	Base
2	Collector;connected to mounting base
3	Emitter

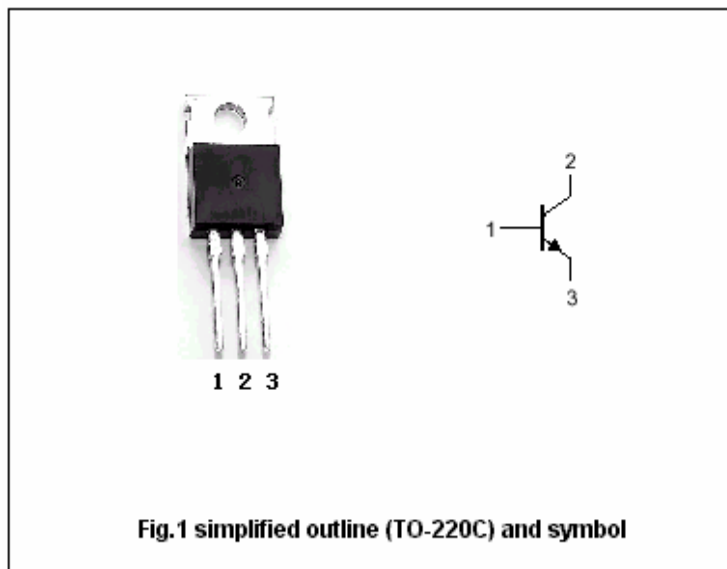
Absolute maximum ratings ($T_a=25^\circ\text{C}$)

SYMBOL	PARAMETER	CONDITIONS	VALUE	UNIT
V_{CBO}	Collector-base voltage	Open emitter	80	V
V_{CEO}	Collector-emitter voltage	Open base	80	V
V_{EBO}	Emitter-base voltage	Open collector	5	V
I_C	Collector current		10	A
I_B	Base current		6	A
P_D	Total power dissipation	$T_C=25^\circ\text{C}$	90	W
T_j	Junction temperature		150	$^\circ\text{C}$
T_{stg}	Storage temperature		-55~150	$^\circ\text{C}$

THERMAL CHARACTERISTICS

SYMBOL	PARAMETER	MAX	UNIT
$R_{th\ j-c}$	Thermal resistance junction to case	1.39	$^\circ\text{C}/\text{W}$

Silicon NPN Power Transistors

BD809

CHARACTERISTICS

T_j=25°C unless otherwise specified

SYMBOL	PARAMETER	CONDITIONS	MIN	TYP.	MAX	UNIT
V _{CE0(SUS)}	Collector-emitter sustaining voltage	I _C =0.1A; I _B =0	80			V
V _{CEsat}	Collector-emitter saturation voltage	I _C =3 A; I _B =0.3 A			1.1	V
V _{BE}	Base-emitter voltage	I _C =4A ; V _{CE} =2V			1.6	V
I _{CBO}	Collector cut-off current	V _{CB} =80V; I _E =0			1.0	mA
I _{EBO}	Emitter cut-off current	V _{EB} =5V; I _C =0			2.0	mA
h _{FE-1}	DC current gain	I _C =2A ; V _{CE} =2V	30			
h _{FE-2}	DC current gain	I _C =4A ; V _{CE} =2V	15			
f _T	Transition frequency	I _C =1A ; V _{CE} =10V; f=1.0MHz	1.5			MHz

Silicon NPN Power Transistors

BD809

PACKAGE OUTLINE

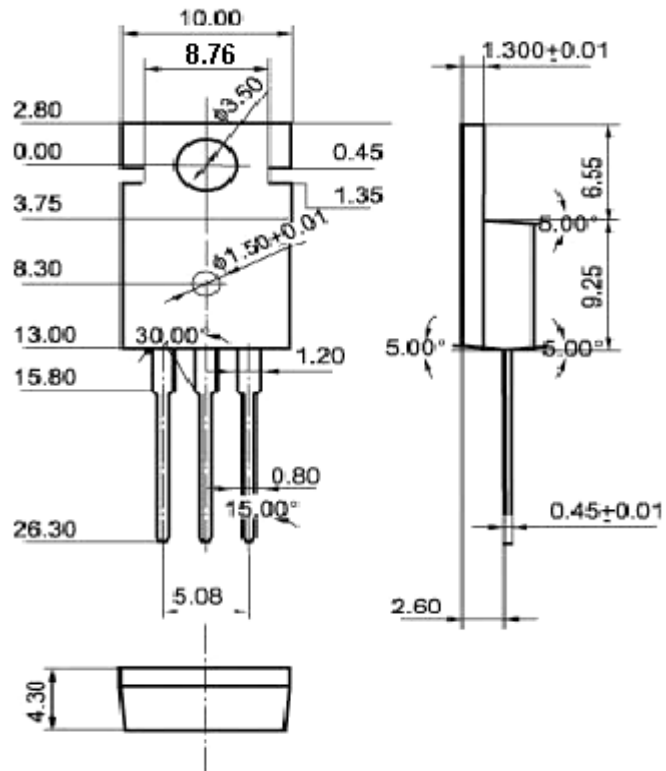

Fig.2 Outline dimensions (unindicated tolerance:±0.10 mm)