

P-CHANNEL ENHANCEMENT MODE POWER MOSFET

MTP3001N3

Description

The MTP3001N3 is a P-channel enhancement-mode MOSFET, providing the designer with the best combination of fast switching, ruggedized device design, low on-resistance and cost effectiveness.

Features

- $R_{DS(ON)}=50m\Omega @V_{GS}=-10V, I_D=-5.3A$
 $R_{DS(ON)}=75m\Omega @V_{GS}=-4.5V, I_D=-4.2A$
- Simple drive requirement
- Low on-resistance
- Fast switching speed
- Pb-free package

Applications

- Power management in notebook computer, portable equipment and battery powered systems.

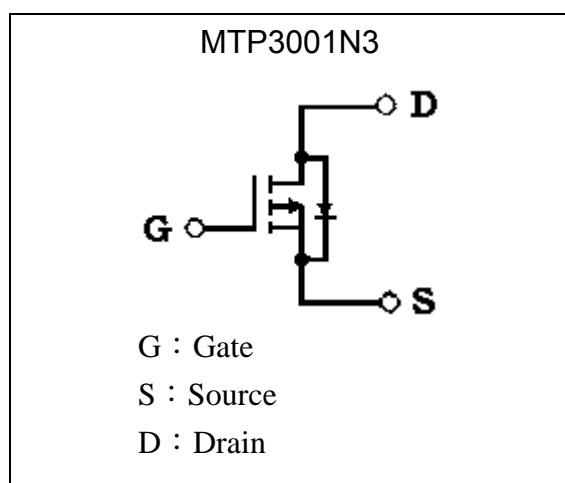
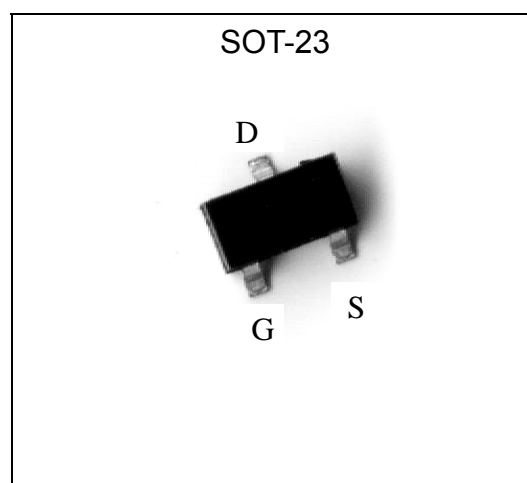
Equivalent Circuit**Outline**



Absolute Maximum Ratings (Ta=25°C)

Parameter	Symbol	Limits	Unit
Drain-Source Breakdown Voltage	BVDSS	-30	V
Gate-Source Voltage	VGS	±20	V
Continuous Drain Current @TA=25 °C (Note 1)	ID	-5.3	A
Continuous Drain Current @TA=70 °C (Note 1)	ID	-4	A
Pulsed Drain Current (Note 2)	IDM	-20	A
Total Power Dissipation @ TA=25 °C (Note 1)	Pd	1.25	W
Operating Junction Temperature	Tj	-55~+150	°C
Storage Temperature	Tstg	-55~+150	°C
Thermal Resistance, Junction-to-Ambient	Rth,ja	50	°C/W

Note : 1.Surface mounted on 1 in² copper pad of FR-4 board, t≤10s.
 2.Pulse width limited by maximum junction temperature.

Electrical Characteristics (Ta=25°C)

Symbol	Min.	Typ.	Max.	Unit	Test Conditions
BVDSS	-30	-	-	V	VGS=0, ID=-250µA
VGS(th)	-1	-1.5	-3	V	VDS=VGS, ID=-250µA
IGSS	-	-	±100	nA	VGS=±20V, VDS=0
IDSS	-	-	-1	µA	VDS=-24V, VGS=0
*RDS(ON)	-	60	70	mΩ	ID=-5.3A, VGS=-10V
	-	75	90		ID=-4.2A, VGS=-4.5V
*GFS	4	7	-	S	VDS=-15V, ID=-5.3A
Ciss	-	551	-	pF	VDS=-15V, VGS=0, f=1MHz
Coss	-	91	-		
Crss	-	61	-		
td(ON)	-	10.8	-	ns	VDD=-15V, ID=-1A, VGS=-10V, RGEN=6Ω, RD=15Ω
tr	-	2.3	-	ns	
td(OFF)	-	23	-	ns	
tf	-	4	-	ns	
Qg	-	9.5	-	nC	VDS=-15V, ID=-5.3A, VGS=-10V,
Qgs	-	3.4	-	nC	
Qgd	-	1.7	-	nC	
ISD	-	-	-1.7	A	-
*VSD	-	-	-1.3	V	VGS=0V, ISD=-1.7A

*Pulse Test : Pulse Width ≤380µs, Duty Cycle≤2%

Ordering Information

Device	Package	Shipping	Marking
MTP3001N3	SOT-23 (Pb-free)	3000 pcs / Tape & Reel	01



Characteristic Curves

On-Resistance vs Gate Voltage

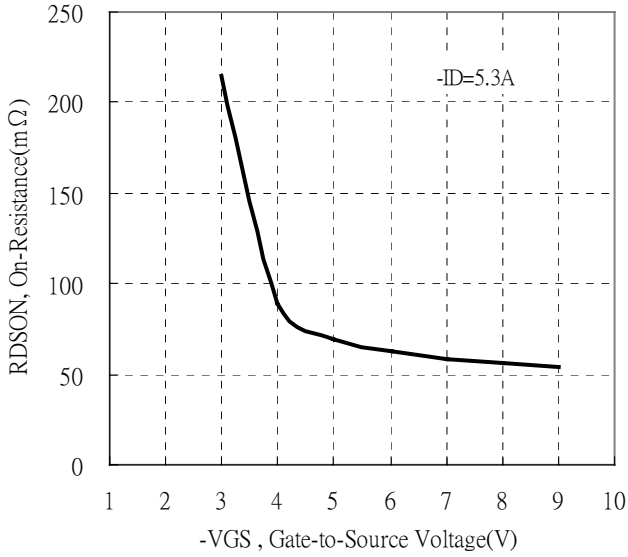

On Resistance vs Drain Current

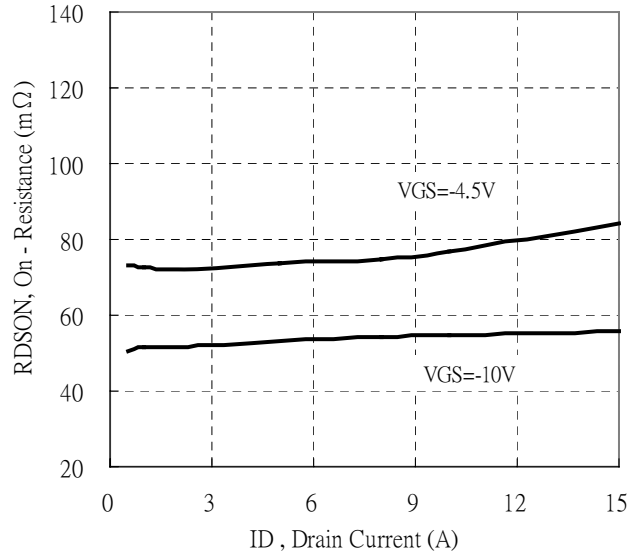

Power Dearting Curve

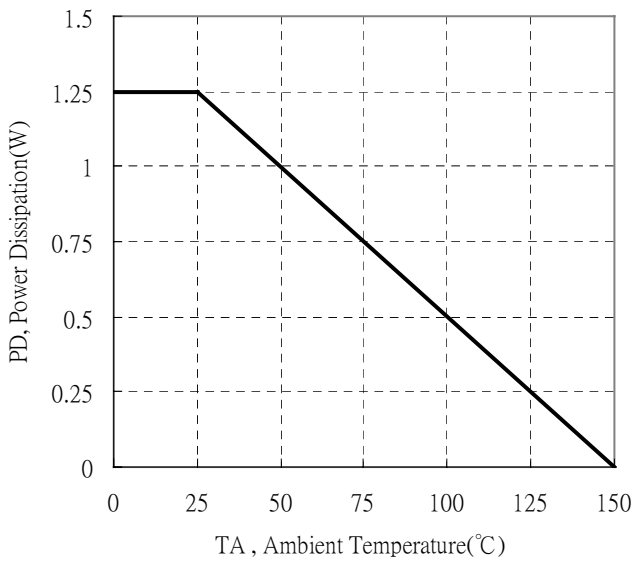

Reel Dimension

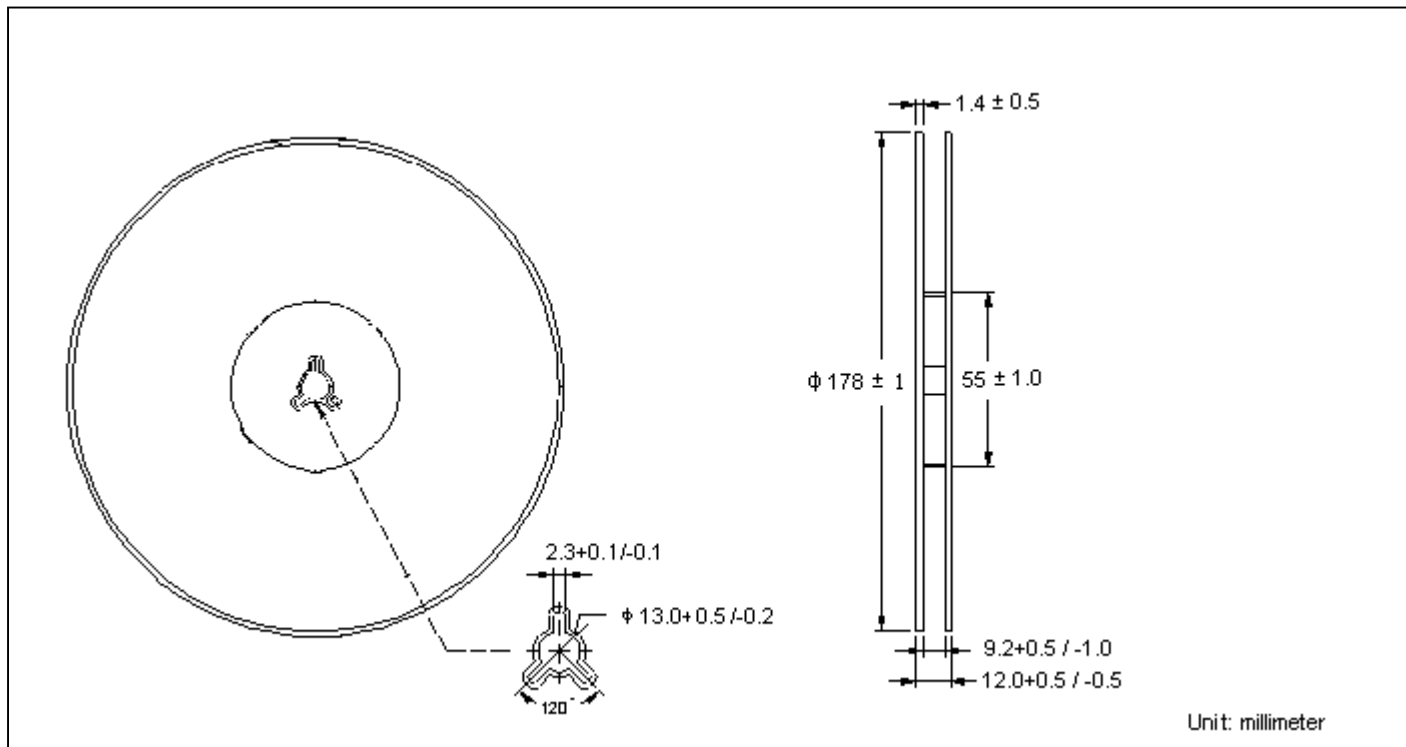

Carrier Tape Dimension

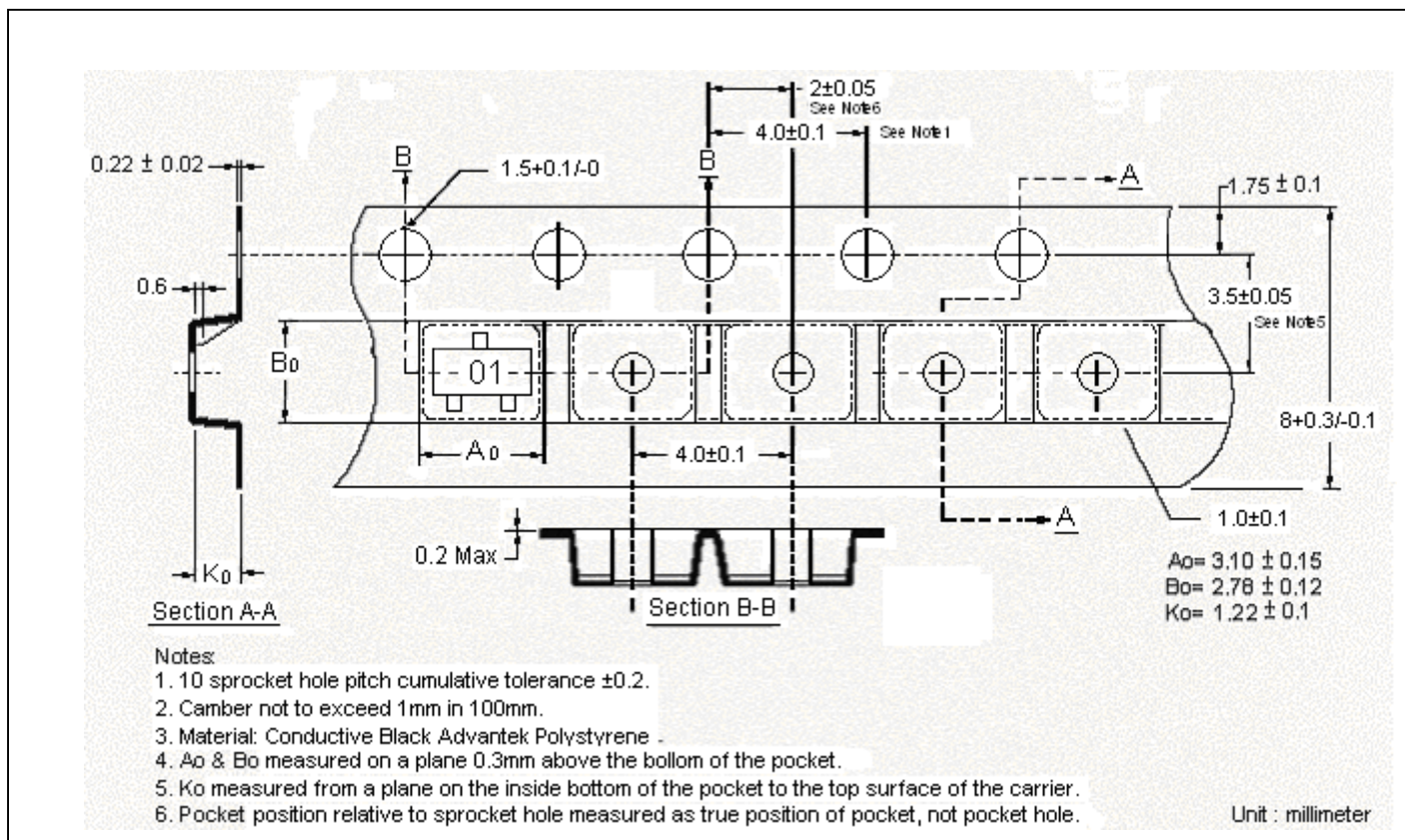

SOT-23 Dimension

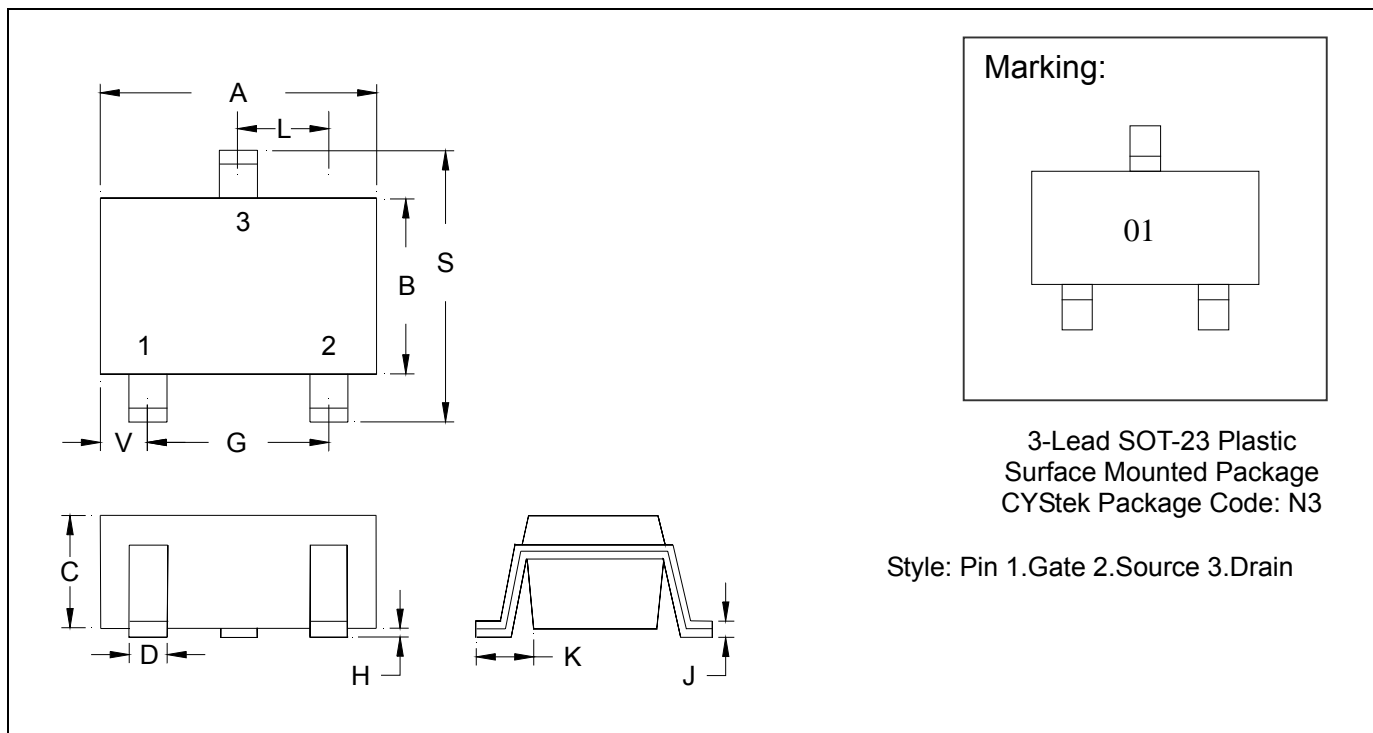

*: Typical

DIM	Inches		Millimeters		DIM	Inches		Millimeters	
	Min.	Max.	Min.	Max.		Min.	Max.	Min.	Max.
A	0.1102	0.1204	2.80	3.04	J	0.0034	0.0070	0.085	0.177
B	0.0472	0.0630	1.20	1.60	K	0.0128	0.0266	0.32	0.67
C	0.0335	0.0512	0.89	1.30	L	0.0335	0.0453	0.85	1.15
D	0.0118	0.0197	0.30	0.50	S	0.0830	0.1083	2.10	2.75
G	0.0669	0.0910	1.70	2.30	V	0.0098	0.0256	0.25	0.65
H	0.0005	0.0040	0.013	0.10					

Notes: 1.Controlling dimension: millimeters.

2.Maximum lead thickness includes lead finish thickness, and minimum lead thickness is the minimum thickness of base material.

3.If there is any question with packing specification or packing method, please contact your local CYStek sales office.

Material:

- Lead: 42 Alloy ; solder plating
- Mold Compound: Epoxy resin family, flammability solid burning class: UL94V-0

Important Notice:

- All rights are reserved. Reproduction in whole or in part is prohibited without the prior written approval of CYStek.
- CYStek reserves the right to make changes to its products without notice.
- CYStek **semiconductor products are not warranted to be suitable for use in Life-Support Applications, or systems.**
- CYStek assumes no liability for any consequence of customer product design, infringement of patents, or application assistance.