



HFP2N60

APPLICATIONS

High-Speed Switching.

ABSOLUTE MAXIMUM RATINGS ($T_a=25$)

T_{stg}	—Storage Temperature.....	-55~150
T_j	—Operating Junction Temperature	150
P_D	— Allowable Power Dissipation ($T_c=25$)	54W
V_{DSS}	— Drain-Source Voltage	600V
V_{GSS}	— Gate-Source Voltage	$\pm 30V$
I_D	— Drain Current($T_c=25$).....	2.0A

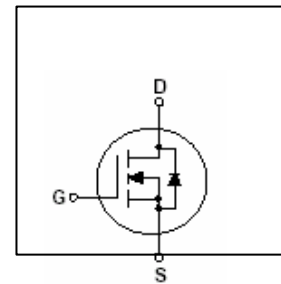
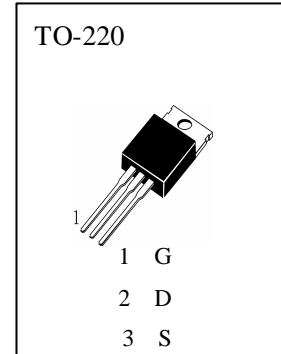

ELECTRICAL CHARACTERISTICS ($T_a=25$)

Symbol	Characteristics	Min	Typ	Max	Unit	Test Conditions
BV_{DSS}	Drain-Source Breakdown Voltage	600			V	$I_D=250 \mu A, V_{GS}=0V$
I_{DSS}	Zero Gate Voltage Drain Current			10	μA	$V_{DS}=600V, V_{GS}=0$
I_{GSS}	Gate -Source Leakage Current			± 100	nA	$V_{GS}=\pm 30V, V_{DS}=0V$
$V_{GS(th)}$	Gate Threshold Voltage	2.0		4.0	V	$V_{DS}=V_{GS}, I_D=250 \mu A$
$R_{DS(on)}$	Static Drain-Source On-Resistance		3.8	5.0		$V_{GS}=10V, I_D=2.0A$
g_{fs}	Forward Transconductance		2.05		S	$V_{DS}=40V, I_D=1.0A$
C_{iss}	Input Capacitance		180	235	pF	} $V_{DS}=25V, V_{GS}=0, f=1MHz$
C_{oss}	Output Capacitance		20	25	pF	
C_{rss}	Reverse Transfer Capacitance		4.3	3	pF	
$t_{d(on)}$	Turn - On Delay Time		9	28	nS	} $V_{DD}=300V, I_D=2.0A$ $R_G=25 *$
t_r	Rise Time		25	60	nS	
$t_{d(off)}$	Turn - Off Delay Time		24	58	nS	
t_f	Fall Time		28	66	nS	} $V_{DS}=480V$ $V_{GS}=10V$ $I_D=2.0A *$
Q_g	Total Gate Charge		8.5	12	nC	
Q_{gs}	Gate-Source Charge		1.3		nC	
Q_{gd}	Gate-Drain Charge		4.1		nC	
I_s	Continuous Source Current			2.0	A	
V_{SD}	Diode Forward Voltage			1.4	V	$I_s=2.0A, V_{GS}=0$
$R_{th(j-c)}$	Thermal Resistance , Junction-to-Case			2.32	/W	

*Pulse Test : Pulse Width 300 μs , Duty Cycle 2%

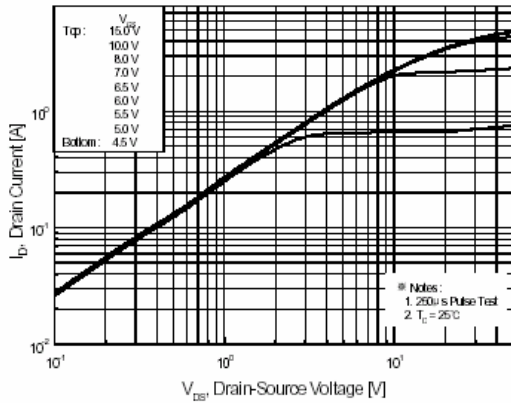

Figure 1. On-Region Characteristics

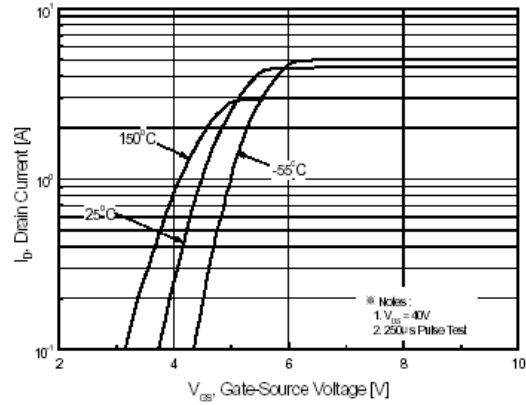

Figure 2. Transfer Characteristics

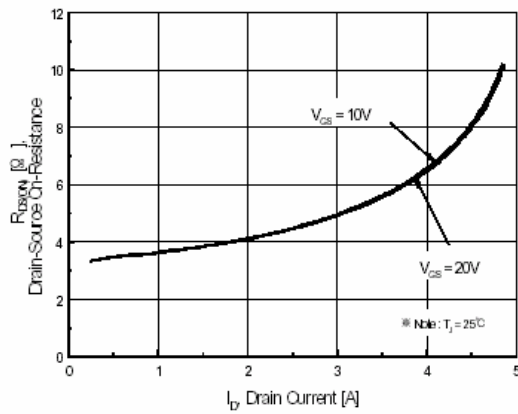

Figure 3. On-Resistance Variation vs Drain Current and Gate Voltage

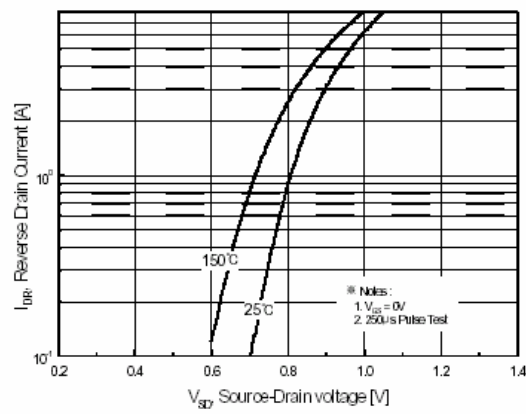

Figure 4. Body Diode Forward Voltage Variation with Source Current and Temperature

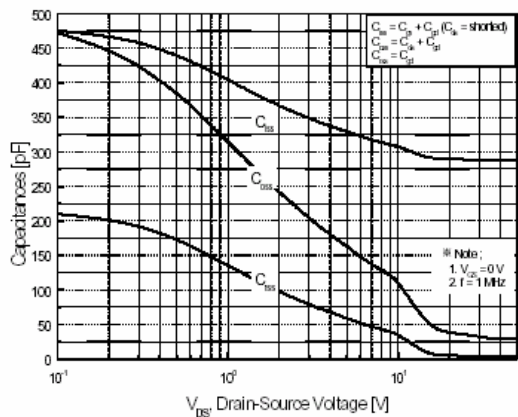

Figure 5. Capacitance Characteristics

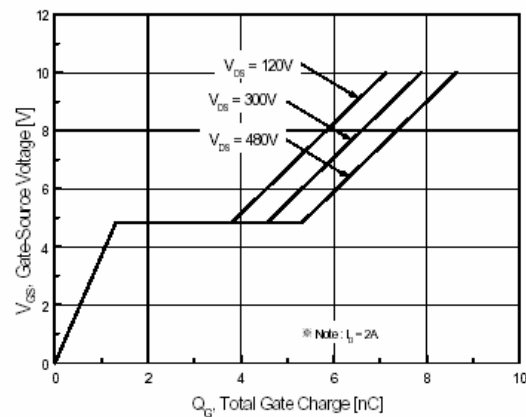

Figure 6. Gate Charge Characteristics

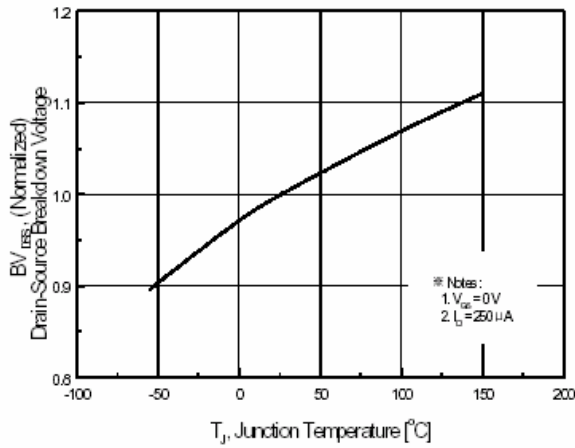

Figure 7. Breakdown Voltage Variation vs Temperature

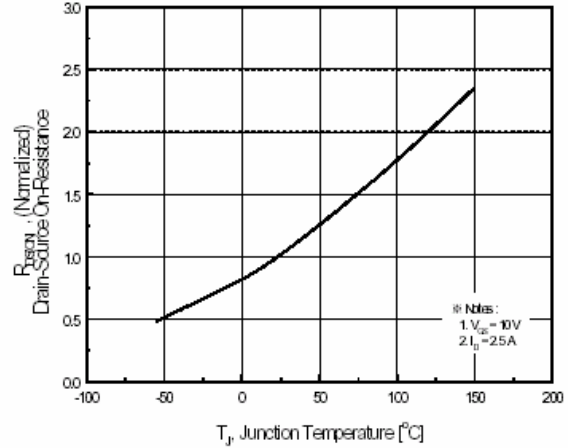

Figure 8. On-Resistance Variation vs Temperature

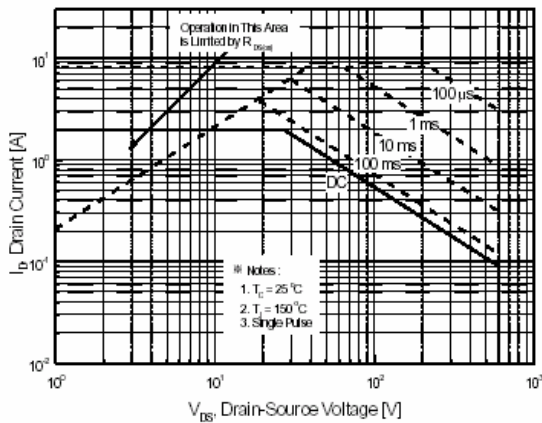

Figure 9-1. Maximum Safe Operating Area for HFP2N60

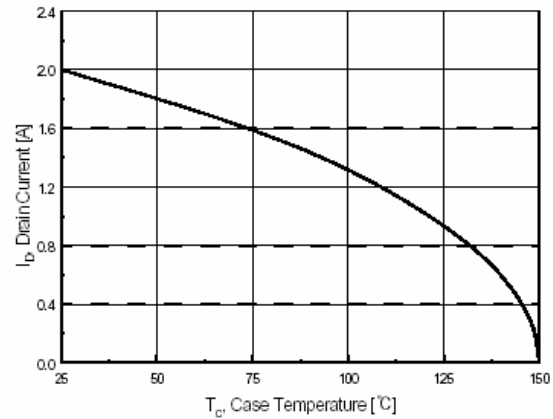

Figure 10. Maximum Drain Current vs Case Temperature

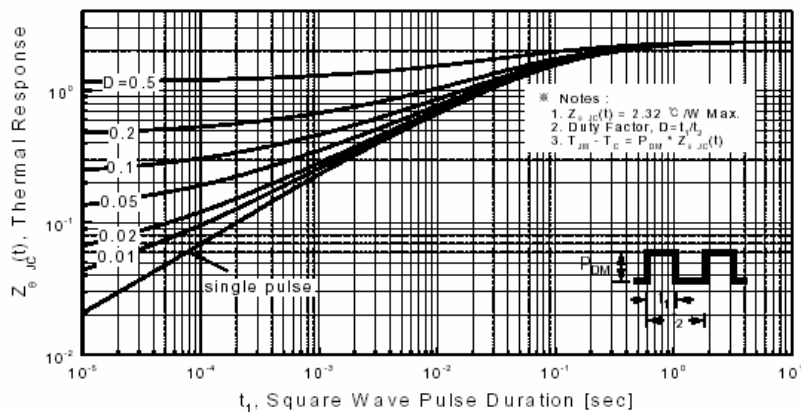
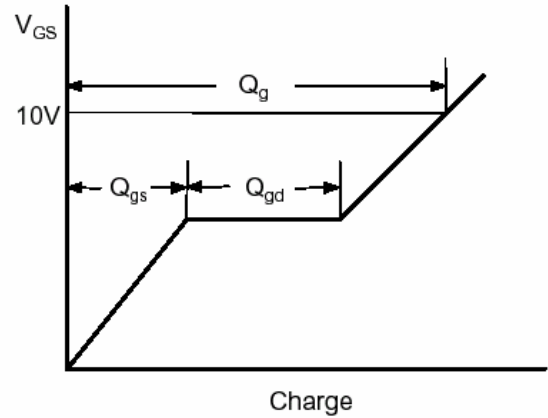
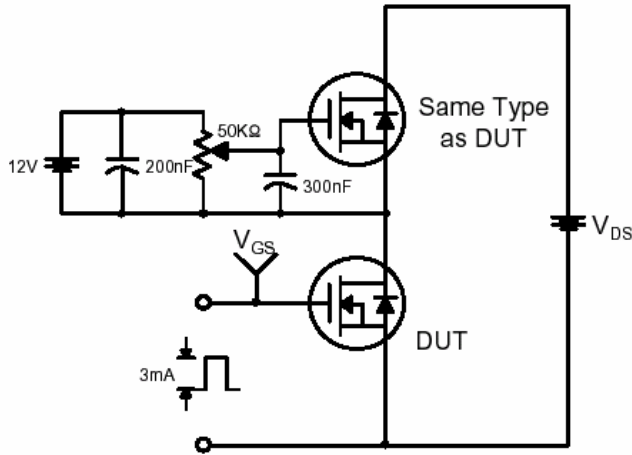

Figure 11-1. Transient Thermal Response Curve for HFP2N60



Gate Charge Test Circuit & Waveform



Resistive Switching Test Circuit & Waveforms

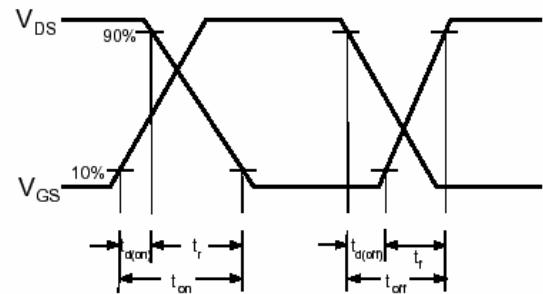
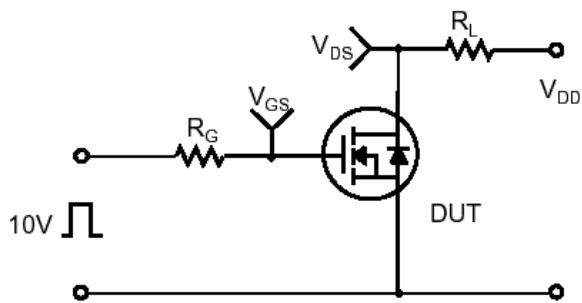

Unclamped Inductive Switching Test Circuit & Waveforms

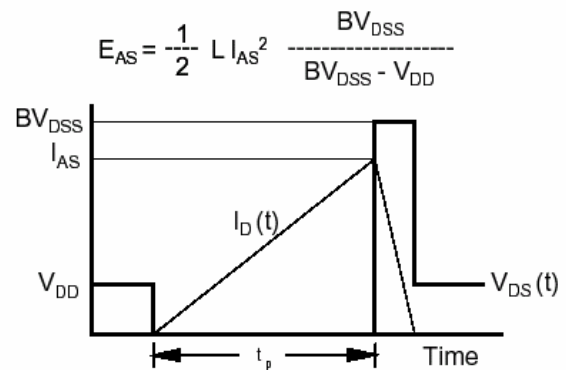
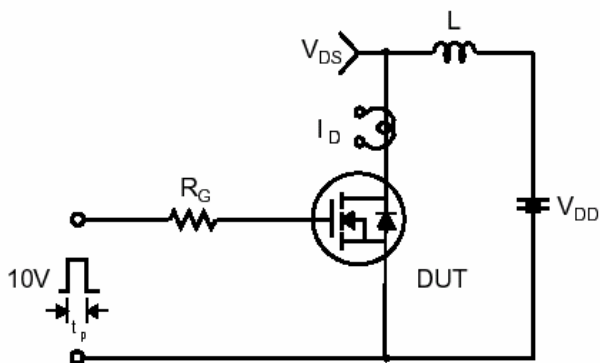



Peak Diode Recovery dv/dt Test Circuit & Waveforms

