



LPC1311/13/42/43

32-bit ARM Cortex-M3 microcontroller; up to 32 kB flash and 8 kB SRAM; USB device

Rev. 01 — 11 December 2009

Product data sheet



1. General description

The LPC1311/13/42/43 are ARM Cortex-M3 based microcontrollers for embedded applications featuring a high level of integration and low power consumption. The ARM Cortex-M3 is a next generation core that offers system enhancements such as enhanced debug features and a higher level of support block integration.

The LPC1311/13/42/43 operate at CPU frequencies of up to 72 MHz. The ARM Cortex-M3 CPU incorporates a 3-stage pipeline and uses a Harvard architecture with separate local instruction and data buses as well as a third bus for peripherals. The ARM Cortex-M3 CPU also includes an internal prefetch unit that supports speculative branching.

The peripheral complement of the LPC1311/13/42/43 includes up to 32 kB of flash memory, up to 8 kB of data memory, USB Device (LPC1342/43 only), one Fast-mode Plus I²C-bus interface, one UART, four general purpose timers, and up to 42 general purpose I/O pins.

2. Features

- ARM Cortex-M3 processor, running at frequencies of up to 72 MHz.
- ARM Cortex-M3 built-in Nested Vectored Interrupt Controller (NVIC).
- 32 kB (LPC1343/13)/16 kB (LPC1342)/8 kB (LPC1311) on-chip flash programming memory.
- 8 kB (LPC1343/13)/4 kB (LPC1342/11) SRAM.
- In-System Programming (ISP) and In-Application Programming (IAP) via on-chip bootloader software.
- Selectable boot-up: UART or USB (USB on LPC134x only).
- Serial interfaces:
 - ◆ USB 2.0 full-speed device controller with on-chip PHY for device (LPC1342/43 only).
 - ◆ UART with fractional baud rate generation, modem, internal FIFO, and RS-485/EIA-485 support.
 - ◆ SSP controller with FIFO and multi-protocol capabilities.
 - ◆ I²C-bus interface supporting full I²C-bus specification and Fast-mode Plus with a data rate of 1 Mbit/s with multiple address recognition and monitor mode.
- Other peripherals:

- ◆ Up to 42 General Purpose I/O (GPIO) pins with configurable pull-up/pull-down resistors.
- ◆ Four general purpose timers/counters with a total of four capture inputs and 13 match outputs.
- ◆ Programmable WatchDog Timer (WDT).
- ◆ System tick timer.
- Serial Wire Debug and Serial Wire Trace port.
- High-current output driver (20 mA) on one pin.
- High-current sink drivers (20 mA) on two I²C-bus pins in Fast-mode Plus.
- Integrated PMU (Power Management Unit) to minimize power consumption during Sleep, Deep-sleep, and Deep power-down modes.
- Three reduced power modes: Sleep, Deep-sleep, and Deep power-down.
- Single 3.3 V power supply (2.0 V to 3.6 V).
- 10-bit ADC with input multiplexing among 8 pins.
- GPIO pins can be used as edge and level sensitive interrupt sources.
- Clock output function with divider that can reflect the system oscillator clock, IRC clock, CPU clock, or the watchdog clock.
- Processor wake-up from Deep-sleep mode via a dedicated start logic using up to 40 of the functional pins.
- Brownout detect with four separate thresholds for interrupt and one threshold for forced reset.
- Power-On Reset (POR).
- Crystal oscillator with an operating range of 1 MHz to 25 MHz.
- 12 MHz internal RC oscillator trimmed to 1 % accuracy that can optionally be used as a system clock.
- PLL allows CPU operation up to the maximum CPU rate without the need for a high-frequency crystal. May be run from the main oscillator, the internal RC oscillator, or the watchdog oscillator.
- Code Read Protection (CRP) with different security levels.
- Available as 48-pin LQFP package and 33-pin HVQFN package.

3. Applications

- eMetering
- Lighting
- Industrial networking
- Alarm systems
- White goods

4. Ordering information

Table 1. Ordering information

Type number	Package		Version
	Name	Description	
LPC1311FHN33	HVQFN33	HVQFN33: plastic thermal enhanced very thin quad flat package; no leads; 33 terminals; body 7 x 7 x 0.85 mm	n/a
LPC1313FBD48	LQFP48	LQFP48: plastic low profile quad flat package; 48 leads; body 7 x 7 x 1.4 mm	SOT313-2
LPC1313FHN33	HVQFN33	HVQFN33: plastic thermal enhanced very thin quad flat package; no leads; 33 terminals; body 7 x 7 x 0.85 mm	n/a
LPC1342FHN33	HVQFN33	HVQFN33: plastic thermal enhanced very thin quad flat package; no leads; 33 terminals; body 7 x 7 x 0.85 mm	n/a
LPC1343FBD48	LQFP48	LQFP48: plastic low profile quad flat package; 48 leads; body 7 x 7 x 1.4 mm	SOT313-2
LPC1343FHN33	HVQFN33	HVQFN33: plastic thermal enhanced very thin quad flat package; no leads; 33 terminals; body 7 x 7 x 0.85 mm	n/a

4.1 Ordering options

Table 2. Ordering options for LPC1311/13/42/43

Type number	Flash	Total SRAM	USB	UART RS-485	I ² C/ Fast+	SSP	ADC channels	Pins	Package
LPC1311FHN33	8 kB	4 kB	-	1	1	1	8	33	HVQFN33
LPC1313FBD48	32 kB	8 kB	-	1	1	1	8	48	LQFP48
LPC1313FHN33	32 kB	8 kB	-	1	1	1	8	33	HVQFN33
LPC1342FHN33	16 kB	4 kB	Device	1	1	1	8	33	HVQFN33
LPC1343FBD48	32 kB	8 kB	Device	1	1	1	8	48	LQFP48
LPC1343FHN33	32 kB	8 kB	Device	1	1	1	8	33	HVQFN33

5. Block diagram

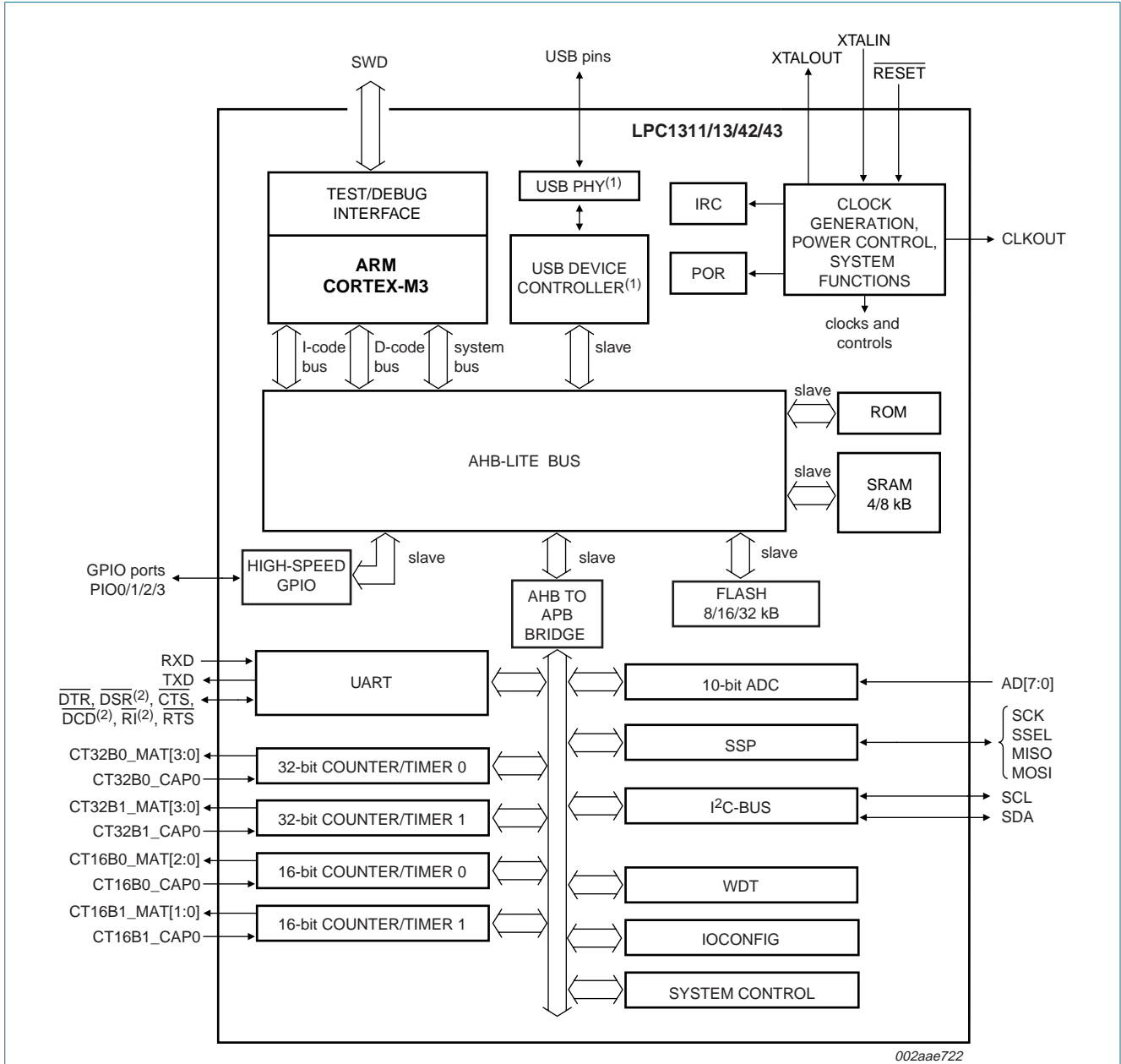

- (1) LPC1342/43 only.
- (2) LQFP48 package only.

Fig 1. Block diagram

6. Pinning information

6.1 Pinning

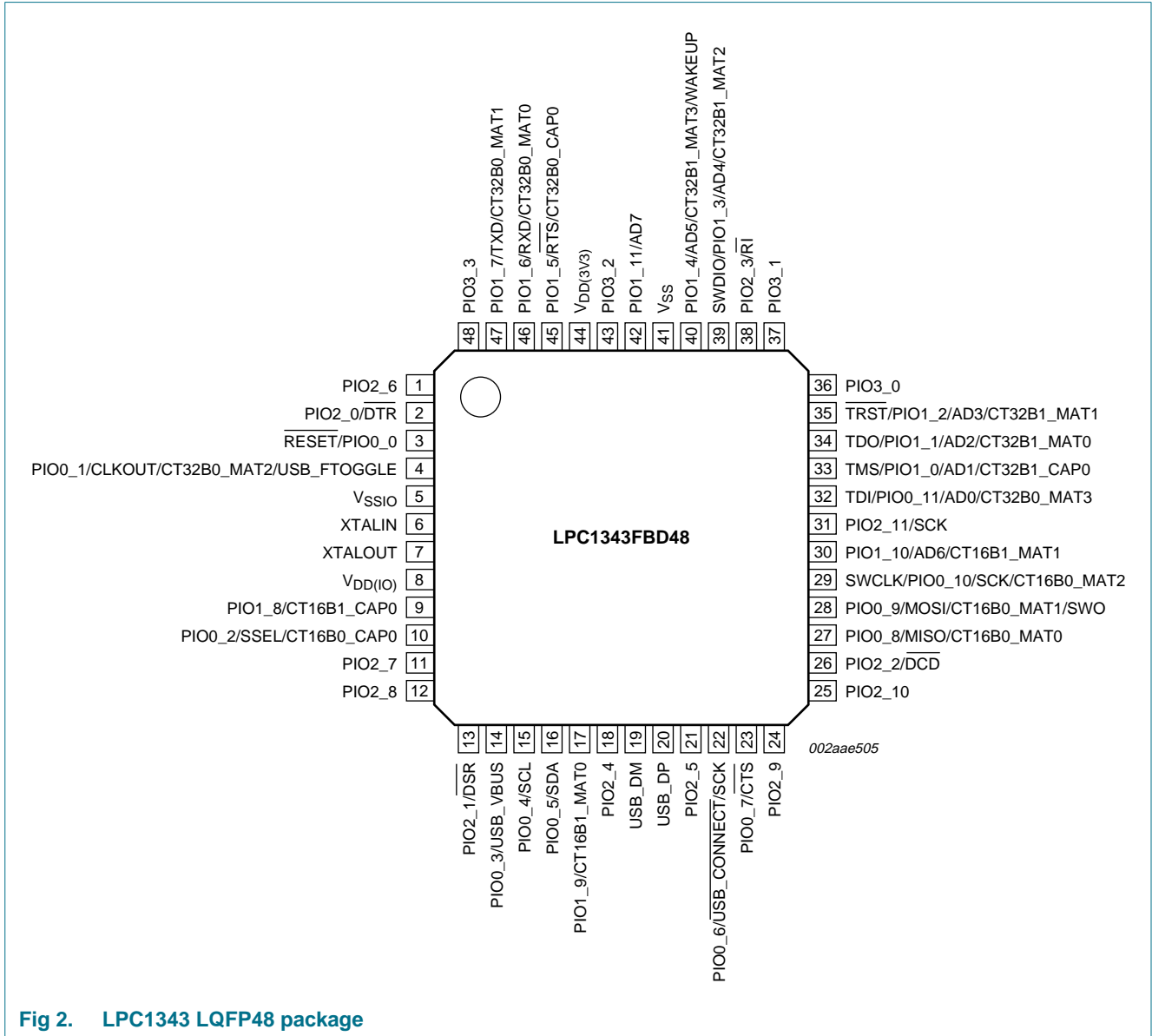

Fig 2. LPC1343 LQFP48 package

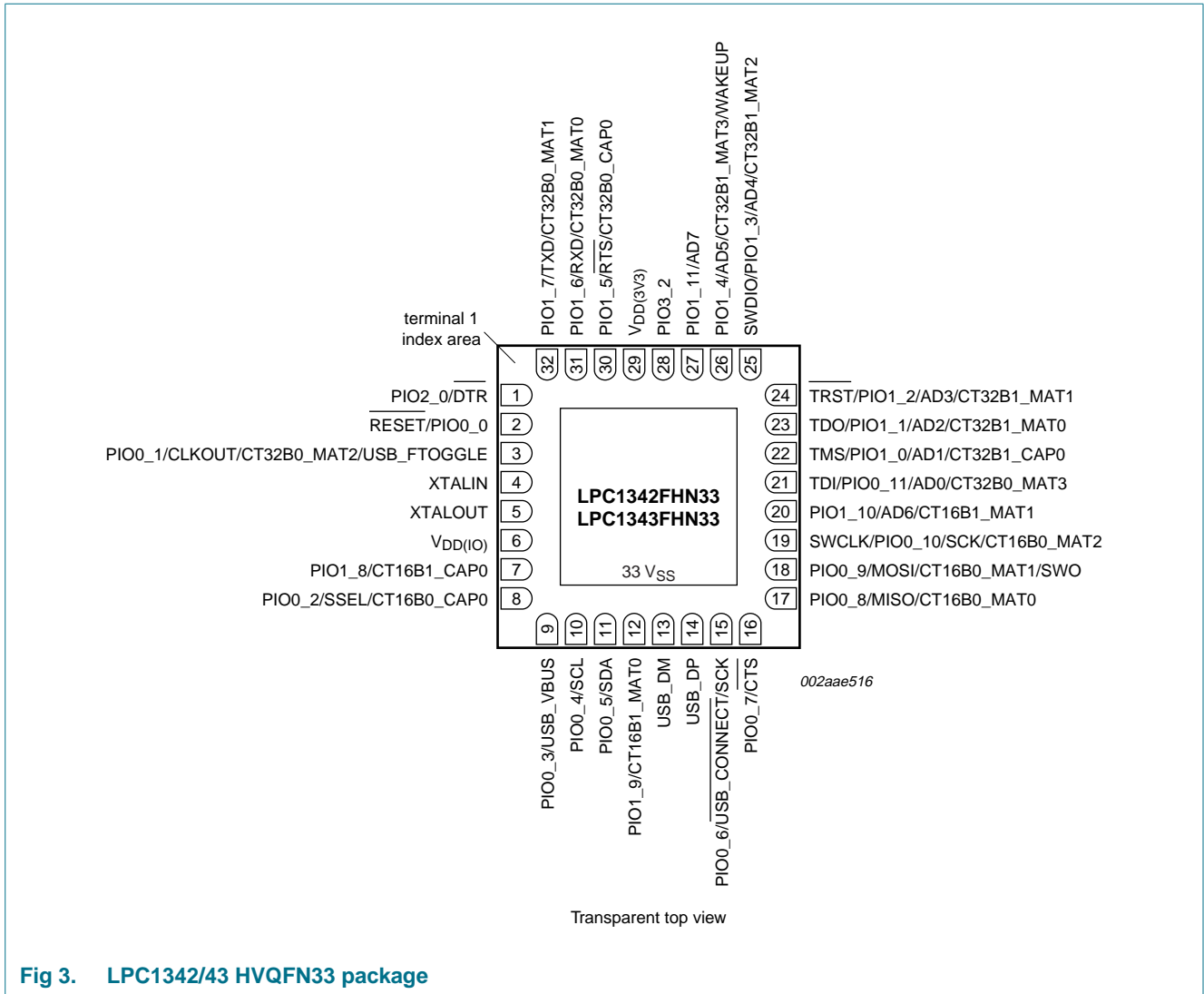

Fig 3. LPC1342/43 HVQFN33 package

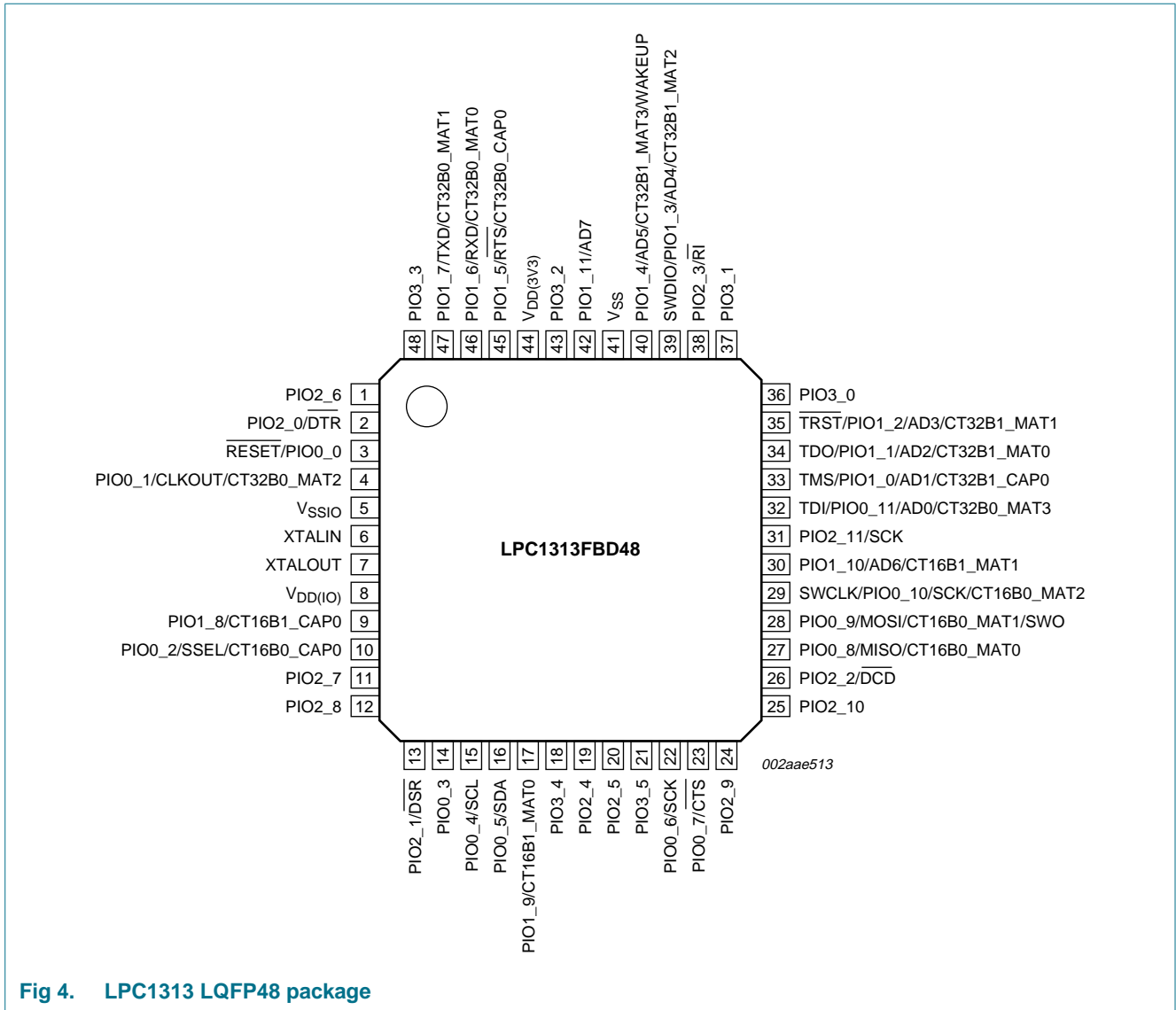

Fig 4. LPC1313 LQFP48 package

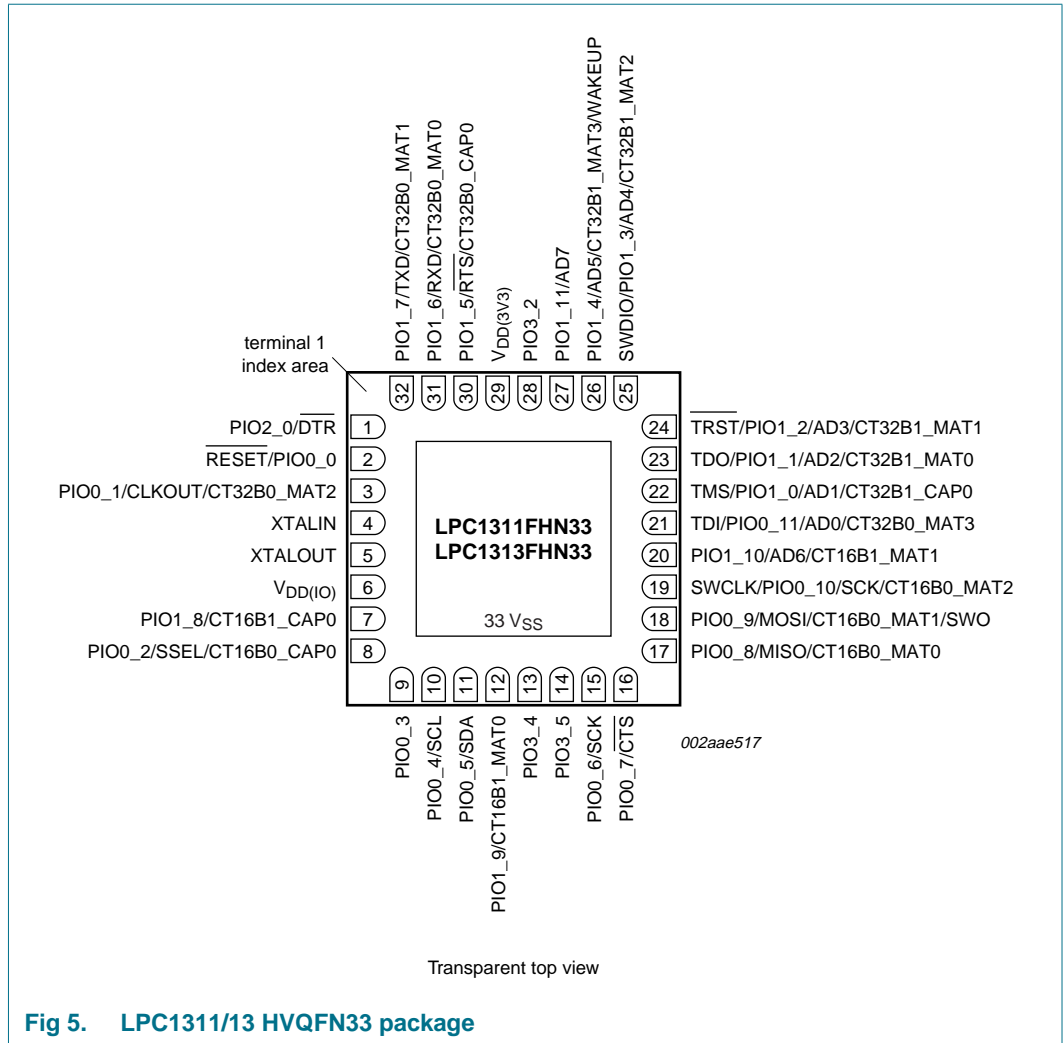

Fig 5. LPC1311/13 HVQFN33 package

6.2 Pin description

Table 3. LPC1313/43 LQFP48 pin description table

Symbol	Pin	Type	Description
RESET/PIO0_0	3	I	RESET — External reset input: A LOW on this pin resets the device, causing I/O ports and peripherals to take on their default states, and processor execution to begin at address 0.
		I/O	PIO0_0 — General purpose digital input/output pin.
PIO0_1/CLKOUT/ CT32B0_MAT2/ USB_FTOGGLE	4 ^[1]	I/O	PIO0_1 — General purpose digital input/output pin. A LOW level on this pin during reset starts the ISP command handler or the USB device enumeration (USB on LPC1343 only, see description of PIO0_3).
		O	CLKOUT — Clockout pin.
		O	CT32B0_MAT2 — Match output 2 for 32-bit timer 0.
		O	USB_FTOGGLE — USB 1 ms Start-of-Frame signal (LPC1343 only).
PIO0_2/SSEL/ CT16B0_CAP0	10 ^[1]	I/O	PIO0_2 — General purpose digital input/output pin.
		O	SSEL — Slave select for SSP.
		I	CT16B0_CAP0 — Capture input 0 for 16-bit timer 0.

Table 3. LPC1313/43 LQFP48 pin description table ...continued

Symbol	Pin	Type	Description
PIO0_3/USB_VBUS	14 ^[1]	I/O	PIO0_3 — General purpose digital input/output pin. LPC1343 only: A LOW level on this pin during reset starts the ISP command handler, a HIGH level starts the USB device enumeration.
		I	USB_VBUS — Monitors the presence of USB bus power (LPC1343 only).
PIO0_4/SCL	15 ^[2]	I/O	PIO0_4 — General purpose digital input/output pin.
		I/O	SCL — I ² C-bus clock input/output. High-current sink only if I ² C Fast-mode Plus is selected in the I/O configuration register.
PIO0_5/SDA	16 ^[2]	I/O	PIO0_5 — General purpose digital input/output pin.
		I/O	SDA — I ² C-bus data input/output. High-current sink only if I ² C Fast-mode Plus is selected in the I/O configuration register.
PIO0_6/USB_CONNECT/ SCK	22 ^[1]	I/O	PIO0_6 — General purpose digital input/output pin.
		O	USB_CONNECT — Signal used to switch an external 1.5 kΩ resistor under software control. Used with the SoftConnect USB feature (LPC1343 only).
		I/O	SCK — Serial clock for SSP.
PIO0_7/CTS	23 ^[1]	I/O	PIO0_7 — General purpose digital input/output pin (high-current output driver).
		I	CTS — Clear To Send input for UART.
PIO0_8/MISO/ CT16B0_MAT0	27 ^[1]	I/O	PIO0_8 — General purpose digital input/output pin.
		I/O	MISO — Master In Slave Out for SSP.
		O	CT16B0_MAT0 — Match output 0 for 16-bit timer 0.
PIO0_9/MOSI/ CT16B0_MAT1/ SWO	28 ^[1]	I/O	PIO0_9 — General purpose digital input/output pin.
		I/O	MOSI — Master Out Slave In for SSP.
		O	CT16B0_MAT1 — Match output 1 for 16-bit timer 0.
		O	SWO — Serial wire trace output.
SWCLK/PIO0_10/ SCK/CT16B0_MAT2	29 ^[1]	I	SWCLK — Serial wire clock and test clock TCK for JTAG interface.
		I/O	PIO0_10 — General purpose digital input/output pin.
		O	SCK — Serial clock for SSP.
		O	CT16B0_MAT2 — Match output 2 for 16-bit timer 0.
TDI/PIO0_11/ AD0/CT32B0_MAT3	32 ^[3]	I	TDI — Test Data In for JTAG interface.
		I/O	PIO0_11 — General purpose digital input/output pin.
		I	AD0 — A/D converter, input 0.
		O	CT32B0_MAT3 — Match output 3 for 32-bit timer 0.
TMS/PIO1_0/ AD1/CT32B1_CAP0	33 ^[3]	I	TMS — Test Mode Select for JTAG interface.
		I/O	PIO1_0 — General purpose digital input/output pin.
		I	AD1 — A/D converter, input 1.
		I	CT32B1_CAP0 — Capture input 0 for 32-bit timer 1.
TDO/PIO1_1/ AD2/CT32B1_MAT0	34 ^[3]	O	TDO — Test Data Out for JTAG interface.
		I/O	PIO1_1 — General purpose digital input/output pin.
		I	AD2 — A/D converter, input 2.
		O	CT32B1_MAT0 — Match output 0 for 32-bit timer 1.

Table 3. LPC1313/43 LQFP48 pin description table ...continued

Symbol	Pin	Type	Description
TRST/PIO1_2/ AD3/CT32B1_MAT1	35 ^[3]	I	TRST — Test Reset for JTAG interface.
		I/O	PIO1_2 — General purpose digital input/output pin.
		I	AD3 — A/D converter, input 3.
		O	CT32B1_MAT1 — Match output 1 for 32-bit timer 1.
SWDIO/PIO1_3/AD4/ CT32B1_MAT2	39 ^[3]	I/O	SWDIO — Serial wire debug input/output.
		I/O	PIO1_3 — General purpose digital input/output pin.
		I	AD4 — A/D converter, input 4.
		O	CT32B1_MAT2 — Match output 2 for 32-bit timer 1.
PIO1_4/AD5/ CT32B1_MAT3/WAKEUP	40 ^[3]	I/O	PIO1_4 — General purpose digital input/output pin.
		I	AD5 — A/D converter, input 5.
		O	CT32B1_MAT3 — Match output 3 for 32-bit timer 1.
		I	WAKEUP — Deep power-down mode wake-up pin. This pin must be pulled HIGH externally to enter Deep power-down mode and pulled LOW to exit Deep power-down mode.
PIO1_5/RTS/ CT32B0_CAP0	45 ^[1]	I/O	PIO1_5 — General purpose digital input/output pin.
		O	RTS — Request To Send output for UART.
		I	CT32B0_CAP0 — Capture input 0 for 32-bit timer 0.
PIO1_6/RXD/ CT32B0_MAT0	46 ^[1]	I/O	PIO1_6 — General purpose digital input/output pin.
		I	RXD — Receiver input for UART.
		O	CT32B0_MAT0 — Match output 0 for 32-bit timer 0.
PIO1_7/TXD/ CT32B0_MAT1	47 ^[1]	I/O	PIO1_7 — General purpose digital input/output pin.
		O	TXD — Transmitter output for UART.
		O	CT32B0_MAT1 — Match output 1 for 32-bit timer 0.
PIO1_8/CT16B1_CAP0	9 ^[1]	I/O	PIO1_8 — General purpose digital input/output pin.
		I	CT16B1_CAP0 — Capture input 0 for 16-bit timer 1.
PIO1_9/CT16B1_MAT0	17 ^[1]	I/O	PIO1_9 — General purpose digital input/output pin.
		O	CT16B1_MAT0 — Match output 0 for 16-bit timer 1.
PIO1_10/AD6/ CT16B1_MAT1	30 ^[3]	I/O	PIO1_10 — General purpose digital input/output pin.
		I	AD6 — A/D converter, input 6.
		O	CT16B1_MAT1 — Match output 1 for 16-bit timer 1.
PIO1_11/AD7	42 ^[3]	I/O	PIO1_11 — General purpose digital input/output pin.
		I	AD7 — A/D converter, input 7.
PIO2_0/DTR	2 ^[1]	I/O	PIO2_0 — General purpose digital input/output pin.
		O	DTR — Data Terminal Ready output for UART.
PIO2_1/DSR	13 ^[1]	I/O	PIO2_1 — General purpose digital input/output pin.
		I	DSR — Data Set Ready input for UART.
PIO2_2/DCD	26 ^[1]	I/O	PIO2_2 — General purpose digital input/output pin.
		I	DCD — Data Carrier Detect input for UART.
PIO2_3/RI	38 ^[1]	I/O	PIO2_3 — General purpose digital input/output pin.
		I	RI — Ring Indicator input for UART.
PIO2_4	18 ^[1]	I/O	PIO2_4 — General purpose digital input/output pin (LPC1343 only).

Table 3. LPC1313/43 LQFP48 pin description table ...continued

Symbol	Pin	Type	Description
PIO2_4	19 ^[1]	I/O	PIO2_4 — General purpose digital input/output pin (LPC1313 only).
PIO2_5	21 ^[1]	I/O	PIO2_5 — General purpose digital input/output pin (LPC1343 only).
PIO2_5	20 ^[1]	I/O	PIO2_5 — General purpose digital input/output pin (LPC1313 only).
PIO2_6	1 ^[1]	I/O	PIO2_6 — General purpose digital input/output pin.
PIO2_7	11 ^[1]	I/O	PIO2_7 — General purpose digital input/output pin.
PIO2_8	12 ^[1]	I/O	PIO2_8 — General purpose digital input/output pin.
PIO2_9	24 ^[1]	I/O	PIO2_9 — General purpose digital input/output pin.
PIO2_10	25 ^[1]	I/O	PIO2_10 — General purpose digital input/output pin.
PIO2_11/SCK	31 ^[1]	I/O	PIO2_11 — General purpose digital input/output pin.
		I/O	SCK — Serial clock for SSP.
PIO3_0	36 ^[1]	I/O	PIO3_0 — General purpose digital input/output pin.
PIO3_1	37 ^[1]	I/O	PIO3_1 — General purpose digital input/output pin.
PIO3_2	43 ^[1]	I/O	PIO3_2 — General purpose digital input/output pin.
PIO3_3	48 ^[1]	I/O	PIO3_3 — General purpose digital input/output pin.
PIO3_4	18 ^[1]	I/O	PIO3_4 — General purpose digital input/output pin (LPC1313 only).
PIO3_5	21 ^[1]	I/O	PIO3_5 — General purpose digital input/output pin (LPC1313 only).
USB_DM	19 ^[4]	I/O	USB_DM — USB bidirectional D– line (LPC1343 only).
USB_DP	20 ^[4]	I/O	USB_DP — USB bidirectional D+ line (LPC1343 only).
V _{DD(I/O)}	8 ^[5]	I	3.3 V input/output supply voltage.
V _{DD(3V3)}	44 ^[5]	I	3.3 V supply voltage to the internal regulator and the ADC. Also used as the ADC reference voltage.
V _{SSIO}	5	I	Ground.
XTALIN	6 ^[6]	I	Input to the oscillator circuit and internal clock generator circuits. Input voltage must not exceed 1.8 V.
XTALOUT	7 ^[6]	O	Output from the oscillator amplifier.
V _{SS}	41	I	Ground.

- [1] 5 V tolerant pad providing digital I/O functions with configurable pull-up/pull-down resistors and configurable hysteresis.
- [2] I²C-bus pads compliant with the I²C-bus specification for I²C standard mode and I²C Fast-mode Plus.
- [3] 5 V tolerant pad providing digital I/O functions with configurable pull-up/pull-down resistors, configurable hysteresis, and analog input. When configured as a ADC input, digital section of the pad is disabled and the pin is not 5 V tolerant.
- [4] Pad provides USB functions. It is designed in accordance with the USB specification, revision 2.0 (Full-speed and Low-speed mode only).
- [5] Tie together V_{DD(3V3)} and V_{DD(I/O)} externally. If separate supplies are used for V_{DD(3V3)} and V_{DD(I/O)}, ensure that the voltage difference between both supplies is smaller than or equal to 0.5 V.
- [6] When the system oscillator is not used, connect XTALIN and XTALOUT as follows: XTALIN can be left floating or can be grounded (grounding is preferred to reduce susceptibility to noise). XTALOUT should be left floating.

Table 4. LPC1311/13/42/43 HVQFN33 pin description table

Symbol	Pin	Type	Description
RESET/PIO0_0	2	I	RESET — External reset input: A LOW on this pin resets the device, causing I/O ports and peripherals to take on their default states, and processor execution to begin at address 0.
		I/O	PIO0_0 — General purpose digital input/output pin.
PIO0_1/CLKOUT/ CT32B0_MAT2/ USB_FTOGGLE	3 ^[1]	I/O	PIO0_1 — General purpose digital input/output pin. A LOW level on this pin during reset starts the ISP command handler or the USB device enumeration (USB on LPC1342/43 only, see description of PIO0_3).
		O	CLKOUT — Clock out pin.
		O	CT32B0_MAT2 — Match output 2 for 32-bit timer 0.
		O	USB_FTOGGLE — USB 1 ms Start-of-Frame signal (LPC1342/43 only).
PIO0_2/SSEL/ CT16B0_CAP0	8 ^[1]	I/O	PIO0_2 — General purpose digital input/output pin.
		O	SSEL — Slave select for SSP.
		I	CT16B0_CAP0 — Capture input 0 for 16-bit timer 0.
PIO0_3/USB_VBUS	9 ^[1]	I/O	PIO0_3 — General purpose digital input/output pin. LPC1342/43 only: A LOW level on this pin during reset starts the ISP command handler, a HIGH level starts the USB device enumeration.
		I	USB_VBUS — Monitors the presence of USB bus power (LPC1342/43 only).
PIO0_4/SCL	10 ^[2]	I/O	PIO0_4 — General purpose digital input/output pin.
		I/O	SCL — I ² C-bus clock input/output. High-current sink only if I ² C Fast-mode Plus is selected in the I/O configuration register.
PIO0_5/SDA	11 ^[2]	I/O	PIO0_5 — General purpose digital input/output pin.
		I/O	SDA — I ² C-bus data input/output. High-current sink only if I ² C Fast-mode Plus is selected in the I/O configuration register.
PIO0_6/USB_CONNECT/ SCK	15 ^[1]	I/O	PIO0_6 — General purpose digital input/output pin.
		O	USB_CONNECT — Signal used to switch an external 1.5 kΩ resistor under software control. Used with the SoftConnect USB feature (LPC1342/43 only).
		I/O	SCK — Serial clock for SSP.
PIO0_7/CTS	16 ^[1]	I/O	PIO0_7 — General purpose digital input/output pin (high-current output driver).
		I	CTS — Clear To Send input for UART.
PIO0_8/MISO/ CT16B0_MAT0	17 ^[1]	I/O	PIO0_8 — General purpose digital input/output pin.
		I/O	MISO — Master In Slave Out for SSP.
		O	CT16B0_MAT0 — Match output 0 for 16-bit timer 0.
PIO0_9/MOSI/ CT16B0_MAT1/ SWO	18 ^[1]	I/O	PIO0_9 — General purpose digital input/output pin.
		I/O	MOSI — Master Out Slave In for SSP.
		O	CT16B0_MAT1 — Match output 1 for 16-bit timer 0.
		O	SWO — Serial wire trace output.
SWCLK/PIO0_10/SCK/ CT16B0_MAT2	19 ^[1]	I	SWCLK — Serial wire clock and test clock TCK for JTAG interface.
		I/O	PIO0_10 — General purpose digital input/output pin.
		O	SCK — Serial clock for SSP.
		O	CT16B0_MAT2 — Match output 2 for 16-bit timer 0.

Table 4. LPC1311/13/42/43 HVQFN33 pin description table ...continued

Symbol	Pin	Type	Description
TDI/PIO0_11/AD0/ CT32B0_MAT3	21 ^[3]	I	TDI — Test Data In for JTAG interface.
		I/O	PIO0_11 — General purpose digital input/output pin.
		I	AD0 — A/D converter, input 0.
		O	CT32B0_MAT3 — Match output 3 for 32-bit timer 0.
TMS/PIO1_0/AD1/ CT32B1_CAP0	22 ^[3]	I	TMS — Test Mode Select for JTAG interface.
		I/O	PIO1_0 — General purpose digital input/output pin.
		I	AD1 — A/D converter, input 1.
		I	CT32B1_CAP0 — Capture input 0 for 32-bit timer 1.
TDO/PIO1_1/AD2/ CT32B1_MAT0	23 ^[3]	O	TDO — Test Data Out for JTAG interface.
		I/O	PIO1_1 — General purpose digital input/output pin.
		I	AD2 — A/D converter, input 2.
		O	CT32B1_MAT0 — Match output 0 for 32-bit timer 1.
TRST/PIO1_2/AD3/ CT32B1_MAT1	24 ^[3]	I	TRST — Test Reset for JTAG interface.
		I/O	PIO1_2 — General purpose digital input/output pin.
		I	AD3 — A/D converter, input 3.
		O	CT32B1_MAT1 — Match output 1 for 32-bit timer 1.
SWDIO/PIO1_3/AD4/ CT32B1_MAT2	25 ^[3]	I/O	SWDIO — Serial wire debug input/output.
		I/O	PIO1_3 — General purpose digital input/output pin.
		I	AD4 — A/D converter, input 4.
		O	CT32B1_MAT2 — Match output 2 for 32-bit timer 1.
PIO1_4/AD5/ CT32B1_MAT3/WAKEUP	26 ^[3]	I/O	PIO1_4 — General purpose digital input/output pin.
		I	AD5 — A/D converter, input 5.
		O	CT32B1_MAT3 — Match output 3 for 32-bit timer 1.
		I	WAKEUP — Deep power-down mode wake-up pin. This pin must be pulled HIGH externally to enter Deep power-down mode and pulled LOW to exit Deep power-down mode.
PIO1_5/RTS/ CT32B0_CAP0	30 ^[1]	I/O	PIO1_5 — General purpose digital input/output pin.
		O	RTS — Request To Send output for UART.
		I	CT32B0_CAP0 — Capture input 0 for 32-bit timer 0.
PIO1_6/RXD/ CT32B0_MAT0	31 ^[1]	I/O	PIO1_6 — General purpose digital input/output pin.
		I	RXD — Receiver input for UART.
		O	CT32B0_MAT0 — Match output 0 for 32-bit timer 0.
PIO1_7/TXD/ CT32B0_MAT1	32 ^[1]	I/O	PIO1_7 — General purpose digital input/output pin.
		O	TXD — Transmitter output for UART.
		O	CT32B0_MAT1 — Match output 1 for 32-bit timer 0.
PIO1_8/CT16B1_CAP0	7 ^[1]	I/O	PIO1_8 — General purpose digital input/output pin.
		I	CT16B1_CAP0 — Capture input 0 for 16-bit timer 1.
PIO1_9/CT16B1_MAT0	12 ^[1]	I/O	PIO1_9 — General purpose digital input/output pin.
		O	CT16B1_MAT0 — Match output 0 for 16-bit timer 1.

Table 4. LPC1311/13/42/43 HVQFN33 pin description table ...continued

Symbol	Pin	Type	Description
PIO1_10/AD6/ CT16B1_MAT1	20 ^[3]	I/O	PIO1_10 — General purpose digital input/output pin.
		I	AD6 — A/D converter, input 6.
		O	CT16B1_MAT1 — Match output 1 for 16-bit timer 1.
PIO1_11/AD7	27 ^[3]	I/O	PIO1_11 — General purpose digital input/output pin.
		I	AD7 — A/D converter, input 7.
PIO2_0/ $\overline{\text{DTR}}$	1 ^[1]	I/O	PIO2_0 — General purpose digital input/output pin.
		O	$\overline{\text{DTR}}$ — Data Terminal Ready output for UART.
PIO3_2	28 ^[1]	I/O	PIO3_2 — General purpose digital input/output pin.
PIO3_4	13 ^[1]	I/O	PIO3_4 — General purpose digital input/output pin (LPC1311/13 only).
PIO3_5	14 ^[1]	I/O	PIO3_5 — General purpose digital input/output pin (LPC1311/13 only).
USB_DM	13 ^[4]	I/O	USB_DM — USB bidirectional D– line (LPC1342/43 only).
USB_DP	14 ^[4]	I/O	USB_DP — USB bidirectional D+ line (LPC1342/43 only).
V _{DD(I/O)}	6 ^[5]	I	3.3 V input/output supply voltage.
V _{DD(3V3)}	29 ^[5]	I	3.3 V supply voltage to the internal DC-DC converter and the ADC. Also used as the ADC reference voltage.
XTALIN	4 ^[6]	I	Input to the oscillator circuit and internal clock generator circuits. Input voltage must not exceed 1.8 V.
XTALOUT	5 ^[6]	O	Output from the oscillator amplifier.
V _{SS}	33	-	Thermal pad. Connect to ground.

- [1] 5 V tolerant pad providing digital I/O functions with configurable pull-up/pull-down resistors and configurable hysteresis.
- [2] I²C-bus pads compliant with the I²C-bus specification for I²C standard mode and I²C Fast-mode Plus.
- [3] 5 V tolerant pad providing digital I/O functions with configurable pull-up/pull-down resistors, configurable hysteresis, and analog input. When configured as a ADC input, digital section of the pad is disabled, and the pin is not 5 V tolerant.
- [4] Pad provides USB functions. It is designed in accordance with the USB specification, revision 2.0 (Full-speed and Low-speed mode only).
- [5] Tie together V_{DD(3V3)} and V_{DD(I/O)} externally. If separate supplies are used for V_{DD(3V3)} and V_{DD(I/O)}, ensure that the voltage difference between both supplies is smaller than or equal to 0.5 V.
- [6] When the system oscillator is not used, connect XTALIN and XTALOUT as follows: XTALIN can be left floating or can be grounded (grounding is preferred to reduce susceptibility to noise). XTALOUT should be left floating.

7. Functional description

7.1 Architectural overview

The ARM Cortex-M3 includes three AHB-Lite buses: the system bus, the I-code bus, and the D-code bus (see [Figure 1](#)). The I-code and D-code core buses are faster than the system bus and are used similarly to TCM interfaces: one bus dedicated for instruction fetch (I-code) and one bus for data access (D-code). The use of two core buses allows for simultaneous operations if concurrent operations target different devices.

7.2 ARM Cortex-M3 processor

The ARM Cortex-M3 is a general purpose, 32-bit microprocessor, which offers high performance and very low power consumption. The ARM Cortex-M3 offers many new features, including a Thumb-2 instruction set, low interrupt latency, hardware divide,

interruptible/continuable multiple load and store instructions, automatic state save and restore for interrupts, tightly integrated interrupt controller, and multiple core buses capable of simultaneous accesses.

Pipeline techniques are employed so that all parts of the processing and memory systems can operate continuously. Typically, while one instruction is being executed, its successor is being decoded, and a third instruction is being fetched from memory.

The ARM Cortex-M3 processor is described in detail in the *Cortex-M3 Technical Reference Manual* which is available on the official ARM website.

7.3 On-chip flash program memory

The LPC1311/13/42/43 contain 32 kB (LPC1313 and LPC1343), 16 kB (LPC1342), or 8 kB (LPC1311) of on-chip flash memory.

7.4 On-chip SRAM

The LPC1311/13/42/43 contain a total of 8 kB (LPC1343 and LPC1313) or 4 kB (LPC1342 and LPC1311) on-chip static RAM memory.

7.5 Memory map

The LPC134x incorporates several distinct memory regions, shown in the following figures. [Figure 6](#) shows the overall map of the entire address space from the user program viewpoint following reset. The interrupt vector area supports address remapping.

The AHB peripheral area is 2 MB in size and is divided to allow for up to 128 peripherals. The APB peripheral area is 1 MB in size and is divided to allow for up to 64 peripherals. Each peripheral of either type is allocated 16 kB of space. This allows simplifying the address decoding for each peripheral.

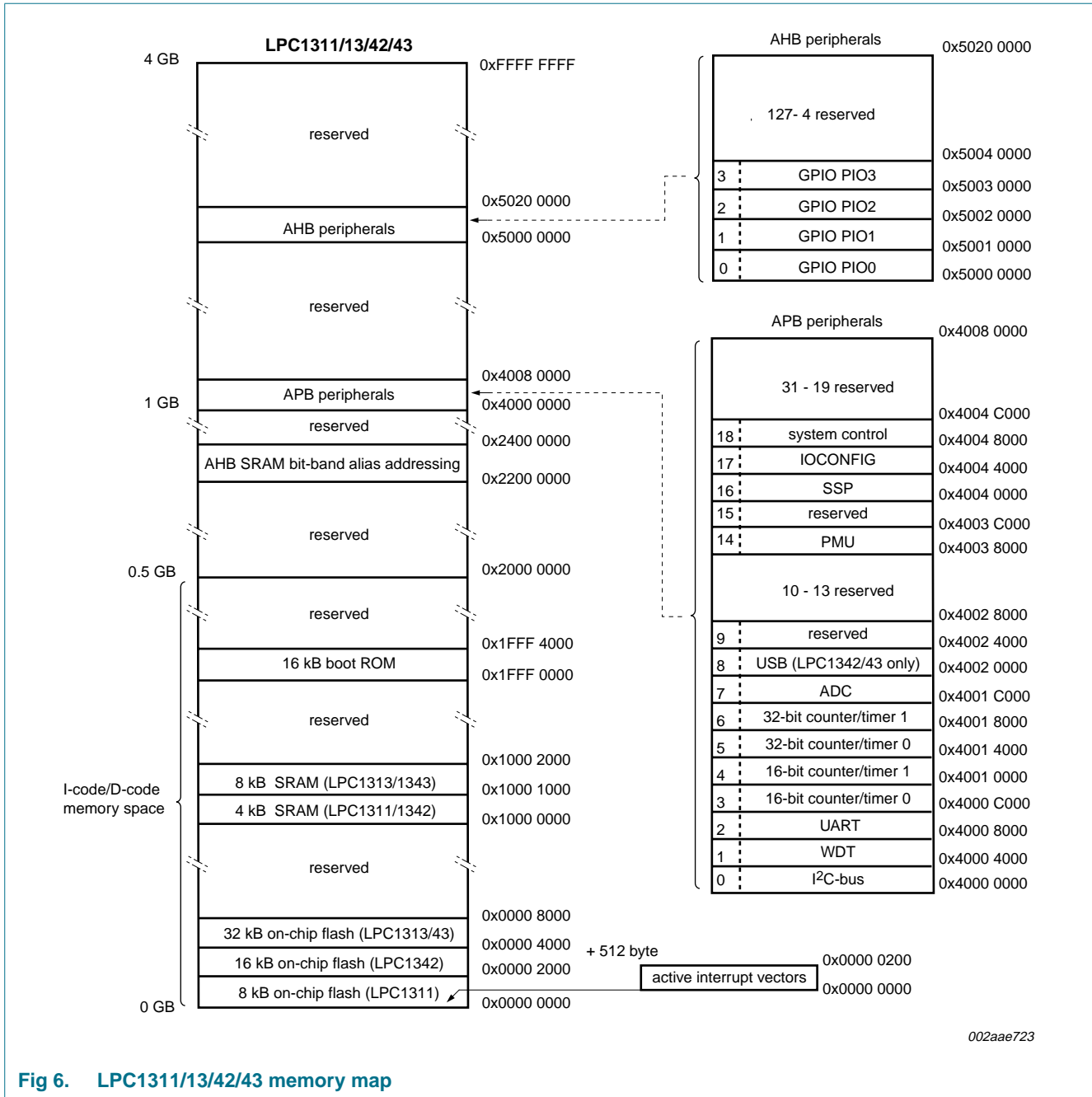

002aae723

Fig 6. LPC1311/13/42/43 memory map

7.6 Nested Vectored Interrupt Controller (NVIC)

The Nested Vectored Interrupt Controller (NVIC) is an integral part of the Cortex-M3. The tight coupling to the CPU allows for low interrupt latency and efficient processing of late arriving interrupts.

7.6.1 Features

- Controls system exceptions and peripheral interrupts.
- On the LPC1311/13/42/43, the NVIC supports 16 vectored interrupts. In addition, up to 40 of the individual GPIO inputs are NVIC-vector capable.

- 8 programmable interrupt priority levels, with hardware priority level masking
- Relocatable vector table.
- Software interrupt generation.

7.6.2 Interrupt sources

Each peripheral device has one interrupt line connected to the NVIC but may have several interrupt flags. Individual interrupt flags may also represent more than one interrupt source.

Any GPIO pin (total of up to 42 pins) regardless of the selected function, can be programmed to generate an interrupt on a level, or rising edge or falling edge, or both.

7.7 IOCONFIG block

The IOCONFIG block allows selected pins of the microcontroller to have more than one function. Configuration registers control the multiplexers to allow connection between the pin and the on-chip peripherals.

Peripherals should be connected to the appropriate pins prior to being activated and prior to any related interrupt(s) being enabled. Activity of any enabled peripheral function that is not mapped to a related pin should be considered undefined.

7.8 Fast general purpose parallel I/O

Device pins that are not connected to a specific peripheral function are controlled by the GPIO registers. Pins may be dynamically configured as inputs or outputs. Separate registers allow setting or clearing any number of outputs simultaneously. The value of the output register may be read back as well as the current state of the port pins.

LPC1311/13/42/43 use accelerated GPIO functions:

- GPIO registers are a dedicated AHB peripheral and are accessed through the AHB so that the fastest possible I/O timing can be achieved.
- Entire port value can be written in one instruction.

Additionally, any GPIO pin (total of up to 42 pins) providing a digital function can be programmed to generate an interrupt on a level, a rising or falling edge, or both.

7.8.1 Features

- Bit level set and clear registers allow a single instruction to set or clear any number of bits in one port.
- Direction control of individual bits.
- All I/O default to inputs with pull-up resistors enabled after reset.
- Pull-up/pull-down resistor configuration can be programmed through the IOCONFIG block for each GPIO pin.

7.9 USB interface (LPC1342/43 only)

The Universal Serial Bus (USB) is a 4-wire bus that supports communication between a host and one or more (up to 127) peripherals. The host controller allocates the USB bandwidth to attached devices through a token-based protocol. The bus supports hot-plugging and dynamic configuration of the devices. All transactions are initiated by the host controller.

The LPC1342/43 USB interface is a device controller with on-chip PHY for device functions.

7.9.1 Full-speed USB device controller

The device controller enables 12 Mbit/s data exchange with a USB Host controller. It consists of a register interface, serial interface engine, and endpoint buffer memory. The serial interface engine decodes the USB data stream and writes data to the appropriate endpoint buffer. The status of a completed USB transfer or error condition is indicated via status registers. An interrupt is also generated if enabled.

7.9.1.1 Features

- Fully compliant with *USB 2.0 specification (full speed)*.
- Supports 10 physical (5 logical) endpoints with up to 64 bytes buffer RAM per endpoint (see [Table 5](#)).
- Supports Control, Bulk, Isochronous, and Interrupt endpoints.
- Supports SoftConnect feature.
- Double buffer implementation for Bulk and Isochronous endpoints.

Table 5. USB device endpoint configuration

Logical endpoint	Physical endpoint	Endpoint type	Direction	Packet size (byte)	Double buffer
0	0	Control	out	64	no
0	1	Control	in	64	no
1	2	Interrupt/Bulk	out	64	no
1	3	Interrupt/Bulk	in	64	no
2	4	Interrupt/Bulk	out	64	no
2	5	Interrupt/Bulk	in	64	no
3	6	Interrupt/Bulk	out	64	yes
3	7	Interrupt/Bulk	in	64	yes
4	8	Isochronous	out	512	yes
4	9	Isochronous	in	512	yes

7.10 UART

The LPC1311/13/42/43 contains one UART.

Support for RS-485/9-bit mode allows both software address detection and automatic address detection using 9-bit mode.

The UART includes a fractional baud rate generator. Standard baud rates such as 115200 Bd can be achieved with any crystal frequency above 2 MHz.

7.10.1 Features

- 16-byte receive and transmit FIFOs.
- Register locations conform to 16C550 industry standard.
- Receiver FIFO trigger points at 1 B, 4 B, 8 B, and 14 B.
- Built-in fractional baud rate generator covering wide range of baud rates without a need for external crystals of particular values.
- Fractional divider for baud rate control, auto baud capabilities and FIFO control mechanism that enables software flow control implementation.
- Support for RS-485/9-bit mode.
- Support for modem control.

7.11 SSP serial I/O controller

The LPC1311/13/42/43 contain one SSP controller. The SSP controller is capable of operation on a SSP, 4-wire SSI, or Microwire bus. It can interact with multiple masters and slaves on the bus. Only a single master and a single slave can communicate on the bus during a given data transfer. The SSP supports full duplex transfers, with frames of 4 bits to 16 bits of data flowing from the master to the slave and from the slave to the master. In practice, often only one of these data flows carries meaningful data.

7.11.1 Features

- Compatible with Motorola SPI, 4-wire Texas Instruments SSI, and National Semiconductor Microwire buses
- Synchronous serial communication
- Master or slave operation
- 8-frame FIFOs for both transmit and receive
- 4-bit to 16-bit frame

7.12 I²C-bus serial I/O controller

The LPC1311/13/42/43 contain one I²C-bus controller.

The I²C-bus is bidirectional for inter-IC control using only two wires: a serial clock line (SCL) and a serial data line (SDA). Each device is recognized by a unique address and can operate as either a receiver-only device (e.g., an LCD driver) or a transmitter with the capability to both receive and send information (such as memory). Transmitters and/or receivers can operate in either master or slave mode, depending on whether the chip has to initiate a data transfer or is only addressed. The I²C is a multi-master bus and can be controlled by more than one bus master connected to it.

7.12.1 Features

- The I²C-bus interface is a standard I²C-bus compliant interface with open-drain pins. The I²C-bus interface also supports Fast-mode Plus with bit rates up to 1 Mbit/s.
- Easy to configure as master, slave, or master/slave.
- Programmable clocks allow versatile rate control.
- Bidirectional data transfer between masters and slaves.

- Multi-master bus (no central master).
- Arbitration between simultaneously transmitting masters without corruption of serial data on the bus.
- Serial clock synchronization allows devices with different bit rates to communicate via one serial bus.
- Serial clock synchronization can be used as a handshake mechanism to suspend and resume serial transfer.
- The I²C-bus can be used for test and diagnostic purposes.
- The I²C-bus controller supports multiple address recognition and a bus monitor mode.

7.13 10-bit ADC

The LPC1311/13/42/43 contains one ADC. It is a single 10-bit successive approximation ADC with eight channels.

7.13.1 Features

- 10-bit successive approximation ADC.
- Input multiplexing among 8 pins.
- Power-down mode.
- Measurement range 0 V to $V_{DD(3V3)}$.
- 10-bit conversion time $\geq 2.44 \mu\text{s}$.
- Burst conversion mode for single or multiple inputs.
- Optional conversion on transition of input pin or timer match signal.
- Individual result registers for each ADC channel to reduce interrupt overhead.

7.14 General purpose external event counters/timers

The LPC1311/13/42/43 includes two 32-bit counter/timers and two 16-bit counter/timers. The counter/timer is designed to count cycles of the system derived clock. It can optionally generate interrupts or perform other actions at specified timer values, based on four match registers. Each counter/timer also includes one capture input to trap the timer value when an input signal transitions, optionally generating an interrupt.

7.14.1 Features

- A 32-bit/16-bit timer/counter with a programmable 32-bit/16-bit prescaler.
- Counter or timer operation.
- One capture channel per timer, that can take a snapshot of the timer value when an input signal transitions. A capture event may also generate an interrupt.
- Four match registers per timer that allow:
 - Continuous operation with optional interrupt generation on match.
 - Stop timer on match with optional interrupt generation.
 - Reset timer on match with optional interrupt generation.
- Up to four external outputs corresponding to match registers, with the following capabilities:

- Set LOW on match.
- Set HIGH on match.
- Toggle on match.
- Do nothing on match.

7.15 System tick timer

The ARM Cortex-M3 includes a system tick timer (SYSTICK) that is intended to generate a dedicated SYSTICK exception, normally set to a 10 ms interval.

7.16 Watchdog timer

The purpose of the watchdog is to reset the microcontroller within a reasonable amount of time if it enters an erroneous state. When enabled, the watchdog will generate a system reset if the user program fails to ‘feed’ (or reload) the watchdog within a predetermined amount of time.

7.16.1 Features

- Internally resets chip if not periodically reloaded.
- Debug mode.
- Enabled by software but requires a hardware reset or a watchdog reset/interrupt to be disabled.
- Incorrect/incomplete feed sequence causes reset/interrupt if enabled.
- Flag to indicate watchdog reset.
- Programmable 32-bit timer with internal prescaler.
- Selectable time period from $(T_{cy(WDCLK)} \times 256 \times 4)$ to $(T_{cy(WDCLK)} \times 2^{32} \times 4)$ in multiples of $T_{cy(WDCLK)} \times 4$.
- The Watchdog Clock (WDCLK) source can be selected from the Internal RC oscillator (IRC), the watchdog oscillator, or the main clock. This gives a wide range of potential timing choices of watchdog operation under different power reduction conditions. It also provides the ability to run the WDT from an entirely internal source that is not dependent on an external crystal and its associated components and wiring for increased reliability.

7.17 Clocking and power control

7.17.1 Crystal oscillators

The LPC1311/13/42/43 include three independent oscillators. These are the system oscillator, the Internal RC oscillator (IRC), and the watchdog oscillator. Each oscillator can be used for more than one purpose as required in a particular application.

Following reset, the LPC1311/13/42/43 will operate from the internal RC oscillator until switched by software. This allows systems to operate without any external crystal and the bootloader code to operate at a known frequency.

See [Figure 7](#) for an overview of the LPC1311/13/42/43 clock generation.

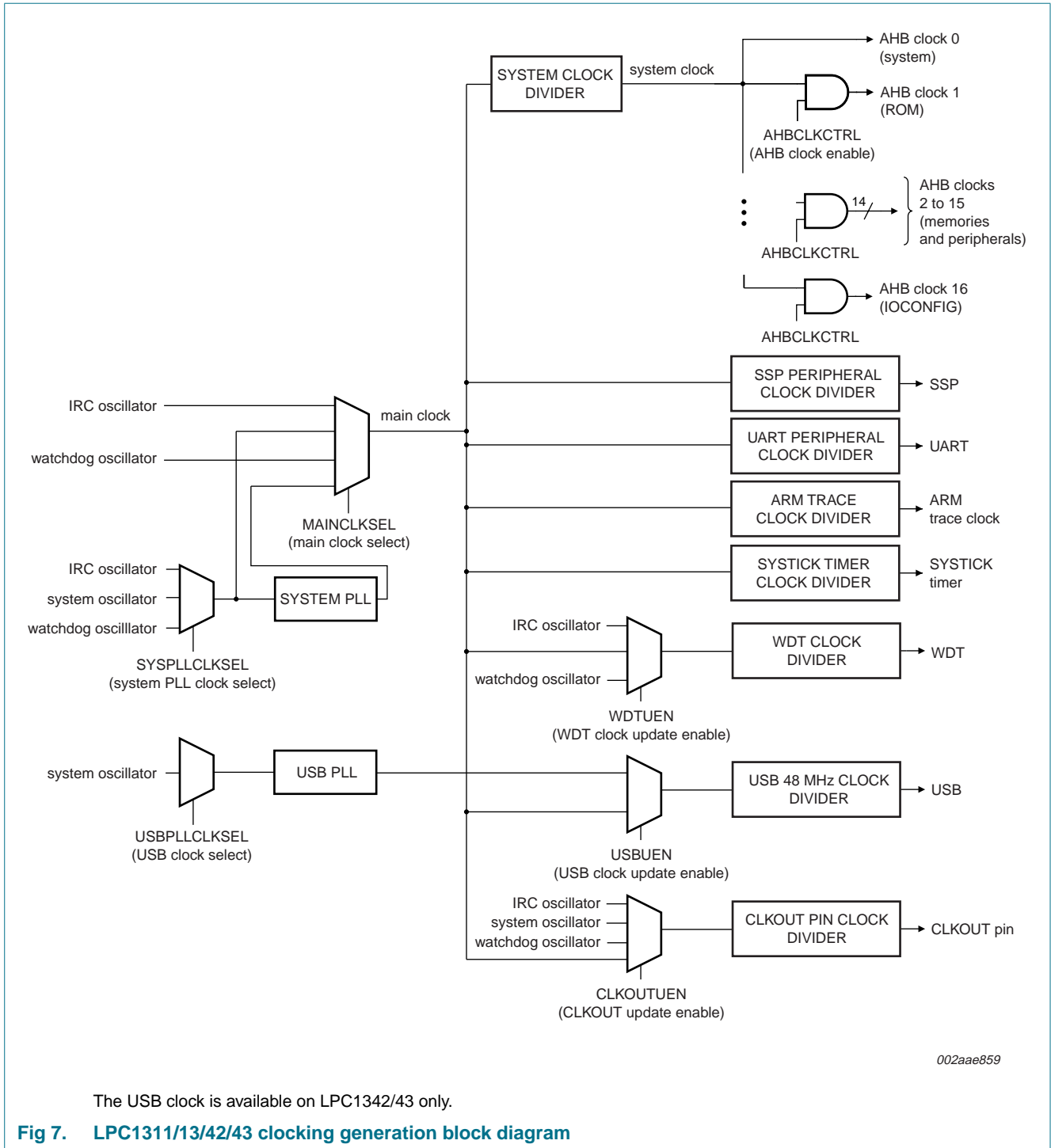

Fig 7. LPC1311/13/42/43 clocking generation block diagram

7.17.1.1 Internal RC oscillator

The IRC may be used as the clock source for the WDT, and/or as the clock that drives the system PLL and subsequently the CPU. The nominal IRC frequency is 12 MHz. The IRC is trimmed to 1 % accuracy over the entire voltage and temperature range.

Upon power-up, any chip reset, or wake-up from Deep power-down mode, the LPC1311/13/42/43 use the IRC as the clock source. Software may later switch to one of the other available clock sources.

7.17.1.2 System oscillator

The system oscillator can be used as the clock source for the CPU, with or without using the PLL. On the LPC134x, the system oscillator must be used to provide the clock source to USB.

The system oscillator operates at frequencies of 1 MHz to 25 MHz. This frequency can be boosted to a higher frequency, up to the maximum CPU operating frequency, by the system PLL.

7.17.2 System PLL and USB PLL

The LPC134x contain a system PLL and a dedicated PLL for generating the 48 MHz USB clock. The LPC131x contain the system PLL only. The system and USB PLLs are identical.

The PLL accepts an input clock frequency in the range of 10 MHz to 25 MHz. The input frequency is multiplied up to a high frequency with a Current Controlled Oscillator (CCO). The multiplier can be an integer value from 1 to 32. The CCO operates in the range of 156 MHz to 320 MHz, so there is an additional divider in the loop to keep the CCO within its frequency range while the PLL is providing the desired output frequency. The output divider may be set to divide by 2, 4, 8, or 16 to produce the output clock. Since the minimum output divider value is 2, it is insured that the PLL output has a 50 % duty cycle. The PLL is turned off and bypassed following a chip reset and may be enabled by software. The program must configure and activate the PLL, wait for the PLL to lock, and then connect to the PLL as a clock source. The PLL settling time is 100 μ s.

7.17.3 Clock output

The LPC1311/13/42/43 features a clock output function that routes the IRC oscillator, the system oscillator, the watchdog oscillator, or the main clock to an output pin.

7.17.4 Wake-up process

The LPC1311/13/42/43 begin operation at power-up and when awakened from Deep power-down mode by using the 12 MHz IRC oscillator as the clock source. This allows chip operation to resume quickly. If the main oscillator or the PLL is needed by the application, software will need to enable these features and wait for them to stabilize before they are used as a clock source.

7.17.5 Power control

The LPC1311/13/42/43 support a variety of power control features. There are three special modes of processor power reduction: Sleep mode, Deep-sleep mode, and Deep power-down mode. The CPU clock rate may also be controlled as needed by changing clock sources, reconfiguring PLL values, and/or altering the CPU clock divider value. This allows a trade-off of power versus processing speed based on application requirements. In addition, a register is provided for shutting down the clocks to individual on-chip peripherals, allowing fine tuning of power consumption by eliminating all dynamic power use in any peripherals that are not required for the application. Selected peripherals have their own clock divider which provides even better power control.

7.17.5.1 Sleep mode

When Sleep mode is entered, the clock to the core is stopped. Resumption from the Sleep mode does not need any special sequence but re-enabling the clock to the ARM core.

In Sleep mode, execution of instructions is suspended until either a reset or interrupt occurs. Peripheral functions continue operation during Sleep mode and may generate interrupts to cause the processor to resume execution. Sleep mode eliminates dynamic power used by the processor itself, memory systems and related controllers, and internal buses.

7.17.5.2 Deep-sleep mode

In Deep-sleep mode, the chip is in Sleep mode, and in addition analog blocks are shut down for increased power savings. The user can configure the Deep-sleep mode to a large extent, selecting any of the oscillators, any of the PLLs, the USB PHY (LPC134x only), BOD, the ADC, and the flash to be shut down or remain powered during Deep-sleep mode. The user can also select which of the oscillators and analog blocks will be powered up after the chip exits from Deep-sleep mode.

The GPIO pins (up to 40 pins total) serve as external wake-up pins to a dedicated start logic to wake up the chip from Deep-sleep mode.

The timing of the wake-up process from Deep-sleep mode depends on which blocks are selected to be powered down during deep-sleep.

For lowest power consumption, the clock source should be switched to IRC before entering Deep-sleep mode, all oscillators and PLLs should be turned off during deep-sleep, and the IRC should be selected as clock source when the chip wakes up from deep-sleep. The IRC can be switched on and off glitch-free and provides a clean clock signal after start-up.

If power consumption is not a concern, any of the oscillators and/or PLLs can be left running in Deep-sleep mode to obtain short wake-up times when waking up from deep-sleep.

7.17.5.3 Deep power-down mode

In Deep power-down mode, power is shut off to the entire chip with the exception of the WAKEUP pin. The LPC1311/13/42/43 can wake up from Deep power-down mode via the WAKEUP pin.

7.18 System control

7.18.1 Reset

Reset has four sources on the LPC1311/13/42/43: the $\overline{\text{RESET}}$ pin, the Watchdog reset, power-on reset (POR), and the Brown-Out Detection (BOD) circuit. The $\overline{\text{RESET}}$ pin is a Schmitt trigger input pin. Assertion of chip reset by any source, once the operating voltage attains a usable level, starts the IRC and initializes the flash controller.

When the internal reset is removed, the processor begins executing at address 0, which is initially the reset vector mapped from the boot block. At that point, all of the processor and peripheral registers have been initialized to predetermined values.

7.18.2 Brownout detection

The LPC1311/13/42/43 includes four levels for monitoring the voltage on the $V_{DD(3V3)}$ pin. If this voltage falls below one of the four selected levels, the BOD asserts an interrupt signal to the NVIC. This signal can be enabled for interrupt in the Interrupt Enable Register in the NVIC in order to cause a CPU interrupt; if not, software can monitor the signal by reading a dedicated status register. An additional threshold level can be selected to cause a forced reset of the chip.

7.18.3 Code security (Code Read Protection - CRP)

This feature of the LPC1311/13/42/43 allows user to enable different levels of security in the system so that access to the on-chip flash and use of the JTAG and ISP can be restricted. When needed, CRP is invoked by programming a specific pattern into a dedicated flash location. IAP commands are not affected by the CRP.

There are three levels of Code Read Protection:

1. CRP1 disables access to chip via the JTAG and allows partial flash update (excluding flash sector 0) using a limited set of the ISP commands. This mode is useful when CRP is required and flash field updates are needed but all sectors can not be erased.
2. CRP2 disables access to chip via the JTAG and only allows full flash erase and update using a reduced set of the ISP commands.
3. Running an application with level CRP3 selected fully disables any access to chip via the JTAG pins and the ISP. This mode effectively disables ISP override using PIO0_1 pin, too. It is up to the user's application to provide (if needed) flash update mechanism using IAP calls or call reinvoke ISP command to enable flash update via UART0.

CAUTION



If level three Code Read Protection (CRP3) is selected, no future factory testing can be performed on the device.

In addition to the three CRP levels, sampling of pin PIO0_1 for valid user code can be disabled. For details see the *LPC13xx user manual*.

7.18.4 Boot loader

The boot loader controls initial operation after reset and also provides the means to program the flash memory. This could be initial programming of a blank device, erasure and re-programming of a previously programmed device, or programming of the flash memory by the application program in a running system.

The boot loader code is executed every time the part is reset or powered up. The loader can either execute the ISP command handler or the user application code, or, on the LPC134x, it can obtain the boot image as an attached MSC device through USB. A LOW level during reset at the PIO0_1 pin is considered an external hardware request to start the ISP command handler or the USB device enumeration. The state of PIO0_3 determines whether the UART or USB interface will be used (LPC134x only).

7.18.5 APB interface

The APB peripherals are located on one APB bus.

7.18.6 AHB-Lite

The AHB-Lite connects the instruction (I-code) and data (D-code) CPU buses of the ARM Cortex-M3 to the flash memory, the main static RAM, and the boot ROM.

7.18.7 External interrupt inputs

All GPIO pins can be level or edge sensitive interrupt inputs.

7.18.8 Memory mapping control

The Cortex-M3 incorporates a mechanism that allows remapping the interrupt vector table to alternate locations in the memory map. This is controlled via the Vector Table Offset Register contained in the NVIC.

The vector table may be located anywhere within the bottom 1 GB of Cortex-M3 address space. The vector table must be located on a 128 word (512 byte) boundary because the NVIC on the LPC1311/13/42/43 is configured for 128 total interrupts.

7.19 Emulation and debugging

Debug functions are integrated into the ARM Cortex-M3. Serial wire debug is supported.

8. Limiting values

Table 6. Limiting values

In accordance with the Absolute Maximum Rating System (IEC 60134).^[1]

Symbol	Parameter	Conditions	Min	Max	Unit
$V_{DD(3V3)}$	supply voltage (3.3 V)	core and external rail	[2] 2.0	3.6	V
$V_{DD(IO)}$	input/output supply voltage		[2] 2.0	3.6	V
V_I	input voltage	5 V tolerant I/O pins; only valid when the $V_{DD(IO)}$ supply voltage is present	[3] -0.5	+5.5	V
I_{DD}	supply current	per supply pin	[4] -	100	mA
I_{SS}	ground current	per ground pin	[4] -	100	mA
I_{latch}	I/O latch-up current	$-(0.5V_{DD(IO)} < V_I < (1.5V_{DD(IO)});$ $T_j < 125\text{ °C}$	-	100	mA
T_{stg}	storage temperature		[5] -65	+150	°C
$T_{j(max)}$	maximum junction temperature		-	150	°C
$P_{tot(pack)}$	total power dissipation (per package)	based on package heat transfer, not device power consumption	-	1.5	W
V_{ESD}	electrostatic discharge voltage	human body model; all pins	[6] -5000	+5000	V

[1] The following applies to the limiting values:

- a) This product includes circuitry specifically designed for the protection of its internal devices from the damaging effects of excessive static charge. Nonetheless, it is suggested that conventional precautions be taken to avoid applying greater than the rated maximum.
 - b) Parameters are valid over operating temperature range unless otherwise specified. All voltages are with respect to V_{SS} unless otherwise noted.
- [2] Tie together $V_{DD(3V3)}$ and $V_{DD(IO)}$ externally. If separate supplies are used for $V_{DD(3V3)}$ and $V_{DD(IO)}$, ensure that the voltage difference between both supplies is smaller than or equal to 0.5 V.
- [3] Including voltage on outputs in 3-state mode.
- [4] The peak current is limited to 25 times the corresponding maximum current.
- [5] Dependent on package type.
- [6] Human body model: equivalent to discharging a 100 pF capacitor through a 1.5 k Ω series resistor.

9. Static characteristics

Table 7. Static characteristics

$T_{amb} = -40\text{ }^{\circ}\text{C}$ to $+85\text{ }^{\circ}\text{C}$, unless otherwise specified.

Symbol	Parameter	Conditions	Min	Typ ^[1]	Max	Unit
$V_{DD(3V3)}$	supply voltage (3.3 V)		[2] 2.0	3.3	3.6	V
$V_{DD(I/O)}$	input/output supply voltage		[2] 2.0	3.3	3.6	V
I_{DD}	supply current	Active mode; $V_{DD(3V3)} = 3.3\text{ V}$; $T_{amb} = 25\text{ }^{\circ}\text{C}$; code while(1){} executed from flash;				
		system clock = 12 MHz	[3][4][5] -	4	-	mA
		system clock = 72 MHz	[4][5][6] -	17	-	mA
		Sleep mode; $V_{DD(3V3)} = 3.3\text{ V}$; $T_{amb} = 25\text{ }^{\circ}\text{C}$; system clock = 12 MHz	[3][4][5] -	2	-	mA
		Deep-sleep mode; $V_{DD(3V3)} = 3.3\text{ V}$; $T_{amb} = 25\text{ }^{\circ}\text{C}$	[7] -	30	-	μA
		Deep power-down mode; $V_{DD(3V3)} = 3.3\text{ V}$; $V_{DD(I/O)} = 3.3\text{ V}$; $T_{amb} = 25\text{ }^{\circ}\text{C}$	[8] -	220	-	nA
$I_{DD(I/O)}$	I/O supply current	Deep power-down mode; $V_{DD(3V3)} = 3.3\text{ V}$; $V_{DD(I/O)} = 3.3\text{ V}$; $T_{amb} = 25\text{ }^{\circ}\text{C}$	[8][9] -	20	-	nA

Standard port pins and RESET pin; see Figure 16, Figure 17, Figure 18 and Figure 19

I_{IL}	LOW-level input current	$V_I = 0\text{ V}$; on-chip pull-up resistor disabled	-	-	3	μA
I_{IH}	HIGH-level input current	$V_I = V_{DD(I/O)}$; on-chip pull-down resistor disabled	-	-	3	μA
I_{OZ}	OFF-state output current	$V_O = 0\text{ V}$; $V_O = V_{DD(I/O)}$; on-chip pull-up/down resistors disabled	-	-	3	μA
V_I	input voltage	pin configured to provide a digital function	[10][11][12] 0	-	5.0	V
V_O	output voltage	output active	0	-	$V_{DD(I/O)}$	V
V_{IH}	HIGH-level input voltage		2.0	-	-	V
V_{IL}	LOW-level input voltage		-	-	0.8	V
V_{hys}	hysteresis voltage		0.4	-	-	V
V_{OH}	HIGH-level output voltage	$I_{OH} = -4\text{ mA}$	[13] $V_{DD(I/O)} - 0.4$	-	-	V
V_{OL}	LOW-level output voltage	$I_{OL} = 4\text{ mA}$	[13] -	-	0.4	V
I_{OH}	HIGH-level output current	$V_{OH} = V_{DD(I/O)} - 0.4\text{ V}$	[13] -4	-	-	mA
I_{OL}	LOW-level output current	$V_{OL} = 0.4\text{ V}$	[13] 4	-	-	mA

Table 7. Static characteristics ...continued
T_{amb} = -40 °C to +85 °C, unless otherwise specified.

Symbol	Parameter	Conditions	Min	Typ ^[1]	Max	Unit
I _{OHS}	HIGH-level short-circuit output current	V _{OH} = 0 V	[14] -	-	-45	mA
I _{OLS}	LOW-level short-circuit output current	V _{OL} = V _{DD(IO)}	[14] -	-	50	mA
I _{pd}	pull-down current	V _I = 5 V	10	50	150	μA
I _{pu}	pull-up current	V _I = 0 V	-15	-50	-85	μA
		V _{DD(IO)} < V _I < 5 V	0	0	0	μA
High-drive output pin (PIO0_7); see Figure 14 and Figure 16						
I _{IL}	LOW-level input current	V _I = 0 V; on-chip pull-up resistor disabled	-	-	3	μA
I _{IH}	HIGH-level input current	V _I = V _{DD(IO)} ; on-chip pull-down resistor disabled	-	-	3	μA
I _{OZ}	OFF-state output current	V _O = 0 V; V _O = V _{DD(IO)} ; on-chip pull-up/down resistors disabled	-	-	3	μA
V _I	input voltage	pin configured to provide a digital function	[10][11][12] 0	-	5.0	V
V _O	output voltage	output active	0	-	V _{DD(IO)}	V
V _{IH}	HIGH-level input voltage		2.0	-	-	V
V _{IL}	LOW-level input voltage		-	-	0.8	V
V _{hys}	hysteresis voltage		0.4	-	-	V
V _{OH}	HIGH-level output voltage	I _{OH} = -20 mA	[13] V _{DD(IO)} - 0.4	-	-	V
V _{OL}	LOW-level output voltage	I _{OL} = 4 mA	[13] -	-	0.4	V
I _{OH}	HIGH-level output current	V _{OH} = V _{DD(IO)} - 0.4 V; V _{DD(IO)} ≥ 2.5 V	[13] 20	-	-	mA
I _{OL}	LOW-level output current	V _{OL} = 0.4 V	[13] 4	-	-	mA
I _{pd}	pull-down current	V _I = 5 V	10	50	150	μA
I _{pu}	pull-up current	V _I = 0 V	-15	-50	-85	μA
		V _{DD(IO)} < V _I < 5 V	0	0	0	μA
I²C-bus pins (PIO0_4 and PIO0_5); see Figure 15						
V _{IH}	HIGH-level input voltage		0.7V _{DD(IO)}	-	-	V
V _{IL}	LOW-level input voltage		-	-	0.3V _{DD(IO)}	V
V _{hys}	hysteresis voltage		-	0.5V _{DD(IO)}	-	V
V _{OL}	LOW-level output voltage	I _{OLS} = 20 mA	[13] -	-	0.4	V
I _{LI}	input leakage current	V _I = V _{DD(IO)}	[15] -	2	4	μA
		V _I = 5 V	-	10	22	μA
Oscillator pins						
V _{i(xtal)}	crystal input voltage		0	1.8	1.95	V
V _{o(xtal)}	crystal output voltage		0	1.8	1.95	V

Table 7. Static characteristics ...continued
T_{amb} = -40 °C to +85 °C, unless otherwise specified.

Symbol	Parameter	Conditions	Min	Typ ^[1]	Max	Unit
USB pins (LPC1342/43 only)						
I _{OZ}	OFF-state output current	0 V < V _I < 3.3 V	-	-	±10	µA
V _{BUS}	bus supply voltage		-	-	5.25	V
V _{DI}	differential input sensitivity voltage	$(D+) - (D-)$	0.2	-	-	V
V _{CM}	differential common mode voltage range	includes V _{DI} range	0.8	-	2.5	V
V _{th(rs)se}	single-ended receiver switching threshold voltage		0.8	-	2.0	V
V _{OL}	LOW-level output voltage	for low-/full-speed; R _L of 1.5 kΩ to 3.6 V	-	-	0.18	V
V _{OH}	HIGH-level output voltage	driven; for low-/full-speed; R _L of 15 kΩ to GND	2.8	-	3.5	V
C _{trans}	transceiver capacitance	pin to GND	-	-	20	pF
Z _{DRV}	driver output impedance for driver which is not high-speed capable	with 33 Ω series resistor; steady state drive	[16] 36	-	44.1	Ω

- [1] Typical ratings are not guaranteed. The values listed are at room temperature (25 °C), nominal supply voltages.
- [2] Tie together V_{DD(3V3)} and V_{DD(I/O)} externally. If separate supplies are used for V_{DD(3V3)} and V_{DD(I/O)}, ensure that the voltage difference between both supplies is smaller than or equal to 0.5 V.
- [3] IRC enabled; system oscillator disabled; system PLL disabled.
- [4] BOD disabled.
- [5] All peripherals disabled in the AHBCLKCTRL register. Peripheral clocks to UART, SSP, trace clock, and SysTick timer disabled in the syscon block.
- [6] IRC disabled; system oscillator enabled; system PLL enabled.
- [7] All oscillators and analog blocks turned off in the PDSLEEPCFG register; PDSLEEPCFG = 0xFFFF FFFF
- [8] WAKEUP pin pulled HIGH externally.
- [9] For LPC134x: USB_DP and USB_DM pulled LOW externally.
- [10] Including voltage on outputs in 3-state mode.
- [11] V_{DD(3V3)} and V_{DD(I/O)} supply voltages must be present.
- [12] 3-state outputs go into 3-state mode when V_{DD(I/O)} is grounded.
- [13] Accounts for 100 mV voltage drop in all supply lines.
- [14] Allowed as long as the current limit does not exceed the maximum current allowed by the device.
- [15] To V_{SS}.
- [16] Includes external resistors of 33 Ω ± 1 % on USB_DP and USB_DM.

Table 8. ADC static characteristics

$T_{amb} = -40\text{ }^{\circ}\text{C}$ to $+85\text{ }^{\circ}\text{C}$ unless otherwise specified; ADC frequency 4.5 MHz, $V_{DD(3V3)} = 2.5\text{ V}$ to 3.6 V .

Symbol	Parameter	Conditions	Min	Typ	Max	Unit
V_{IA}	analog input voltage		0	-	$V_{DD(3V3)}$	V
C_{ia}	analog input capacitance		-	-	1	pF
E_D	differential linearity error		[1][2] -	-	± 1	LSB
$E_{L(adj)}$	integral non-linearity		[3] -	-	± 1.5	LSB
E_O	offset error		[4] -	-	± 3.5	LSB
E_G	gain error		[5] -	-	0.6	%
E_T	absolute error		[6] -	-	± 4	LSB

- [1] The ADC is monotonic, there are no missing codes.
- [2] The differential linearity error (E_D) is the difference between the actual step width and the ideal step width. See [Figure 8](#).
- [3] The integral non-linearity ($E_{L(adj)}$) is the peak difference between the center of the steps of the actual and the ideal transfer curve after appropriate adjustment of gain and offset errors. See [Figure 8](#).
- [4] The offset error (E_O) is the absolute difference between the straight line which fits the actual curve and the straight line which fits the ideal curve. See [Figure 8](#).
- [5] The gain error (E_G) is the relative difference in percent between the straight line fitting the actual transfer curve after removing offset error, and the straight line which fits the ideal transfer curve. See [Figure 8](#).
- [6] The absolute error (E_T) is the maximum difference between the center of the steps of the actual transfer curve of the non-calibrated ADC and the ideal transfer curve. See [Figure 8](#).

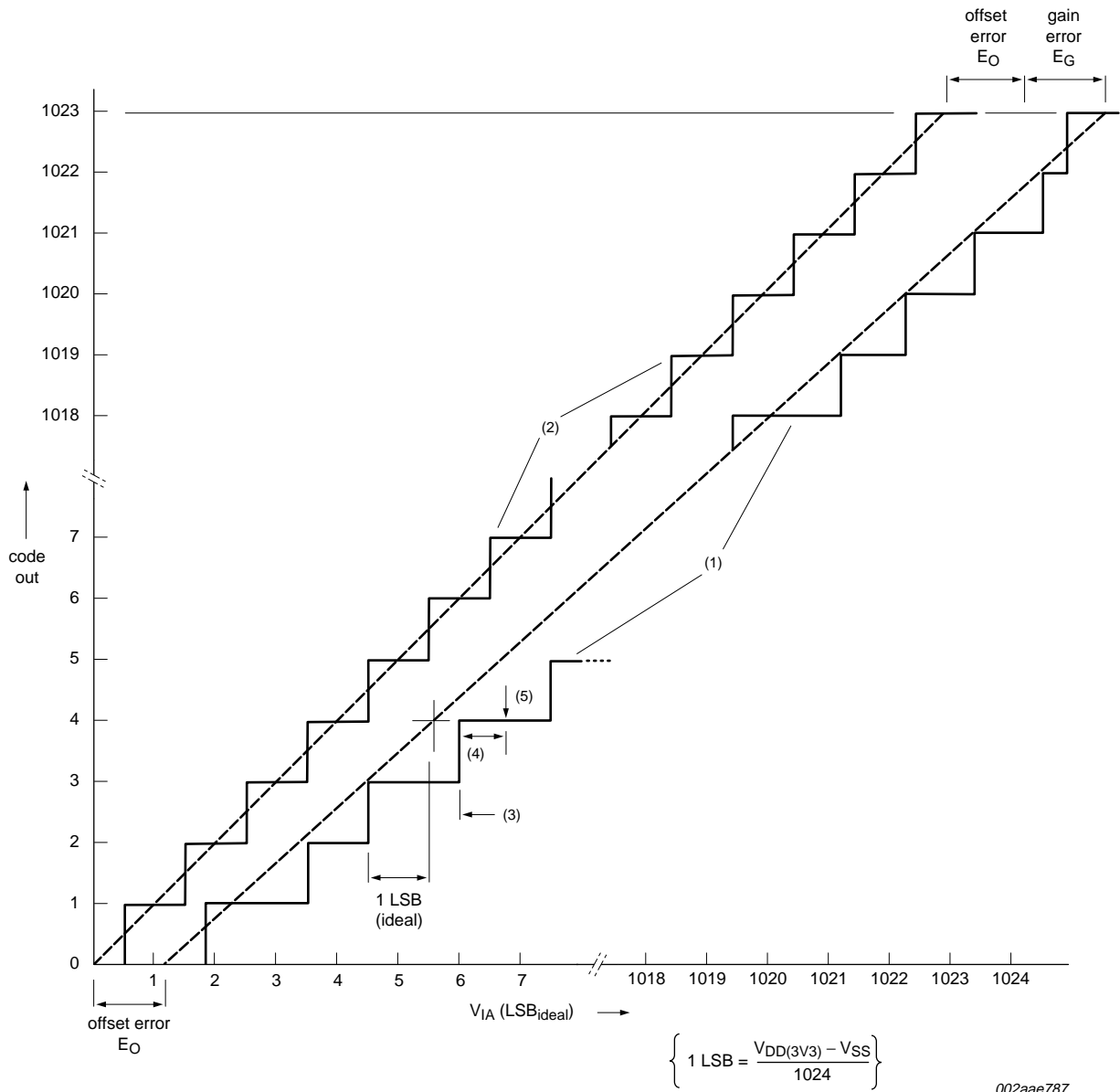

002aae787

- (1) Example of an actual transfer curve.
- (2) The ideal transfer curve.
- (3) Differential linearity error (E_D).
- (4) Integral non-linearity (E_{L(adj)}).
- (5) Center of a step of the actual transfer curve.

Fig 8. ADC characteristics

9.1 BOD static characteristics

Table 9. BOD static characteristics[1]

T_{amb} = 25 °C.

Symbol	Parameter	Conditions	Min	Typ	Max	Unit
V _{th}	threshold voltage	interrupt level 0				
		assertion	-	1.69	-	V
		de-assertion	-	1.84	-	V
		interrupt level 1				
		assertion	-	2.29	-	V
		de-assertion	-	2.44	-	V
		interrupt level 2				
		assertion	-	2.59	-	V
		de-assertion	-	2.74	-	V
		interrupt level 3				
		assertion	-	2.87	-	V
		de-assertion	-	2.98	-	V
		reset level 0				
		assertion	-	1.49	-	V
de-assertion	-	1.64	-	V		

[1] Interrupt levels are selected by writing the level value to the BOD control register BODCTRL, see LPC13xx user manual.

9.2 Power consumption

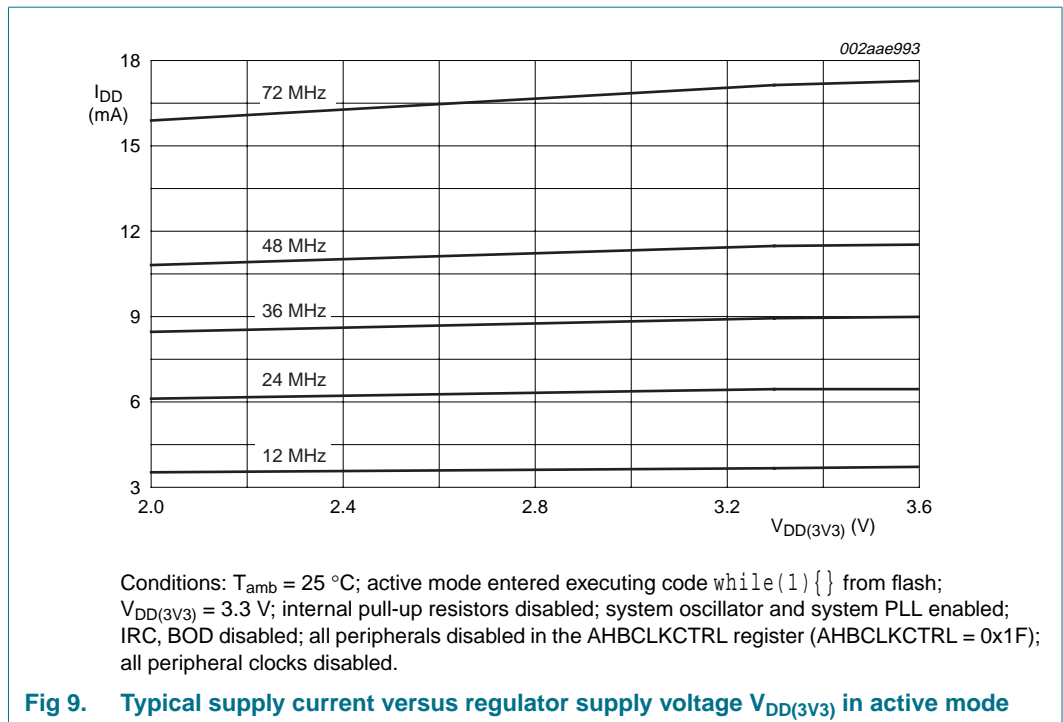

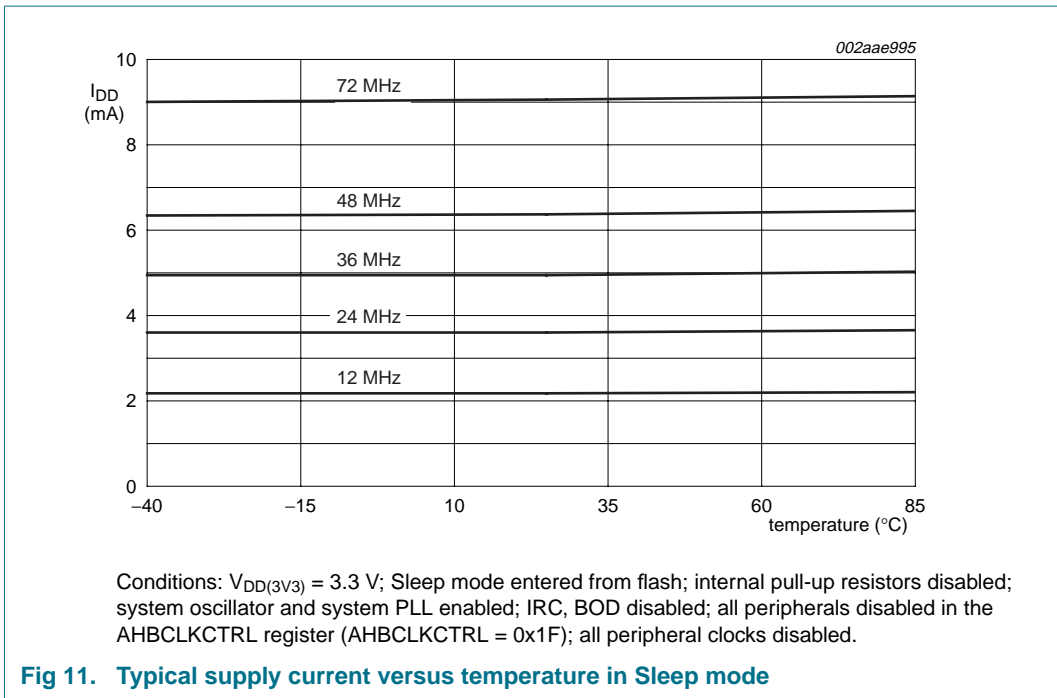
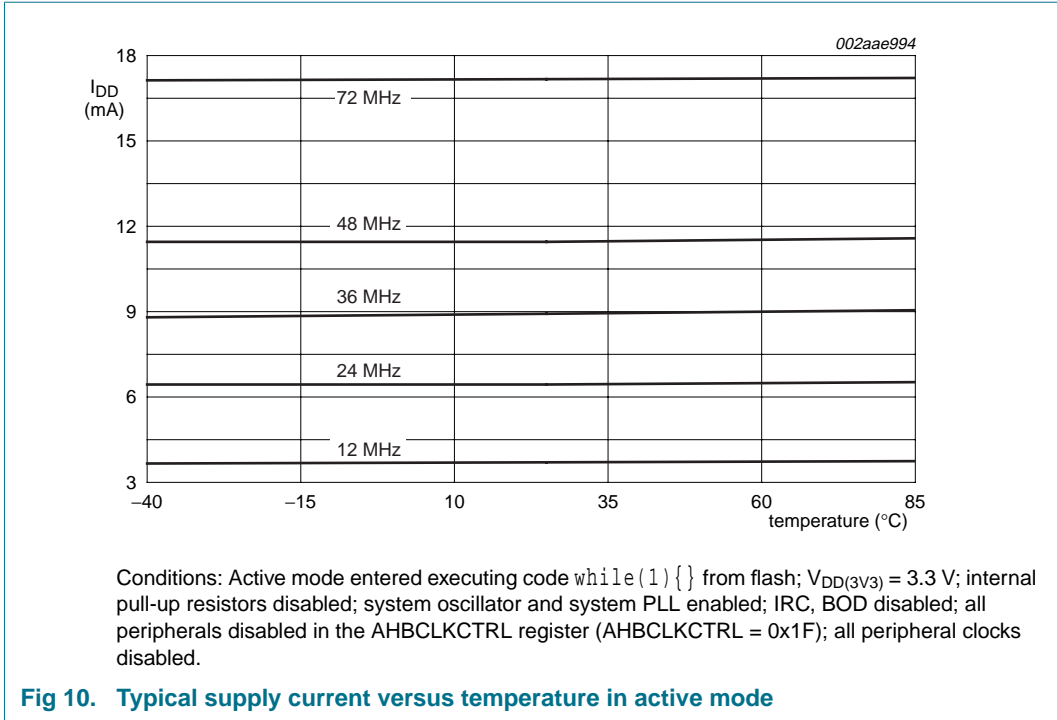

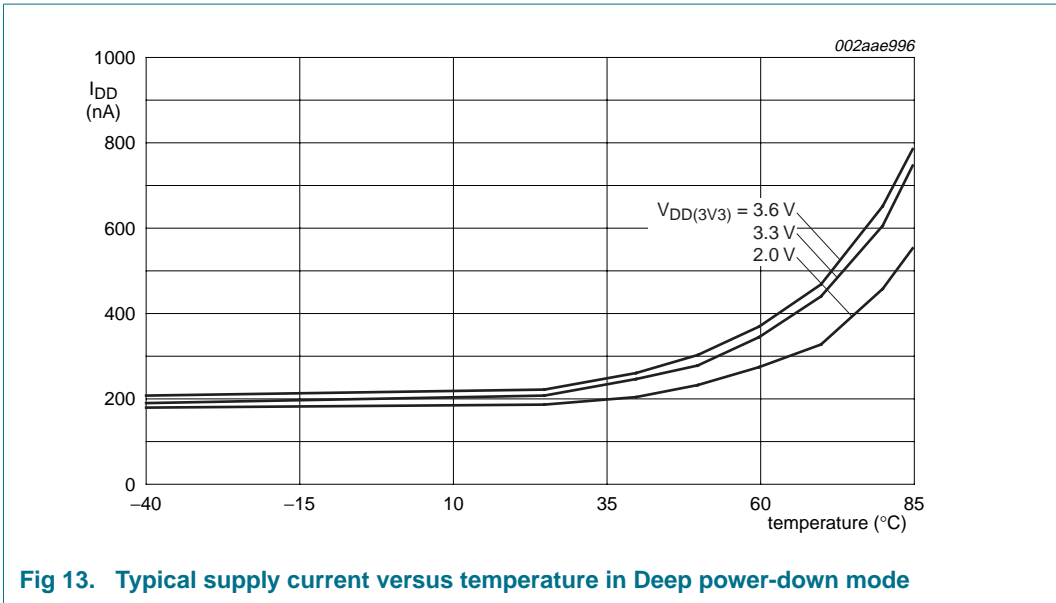
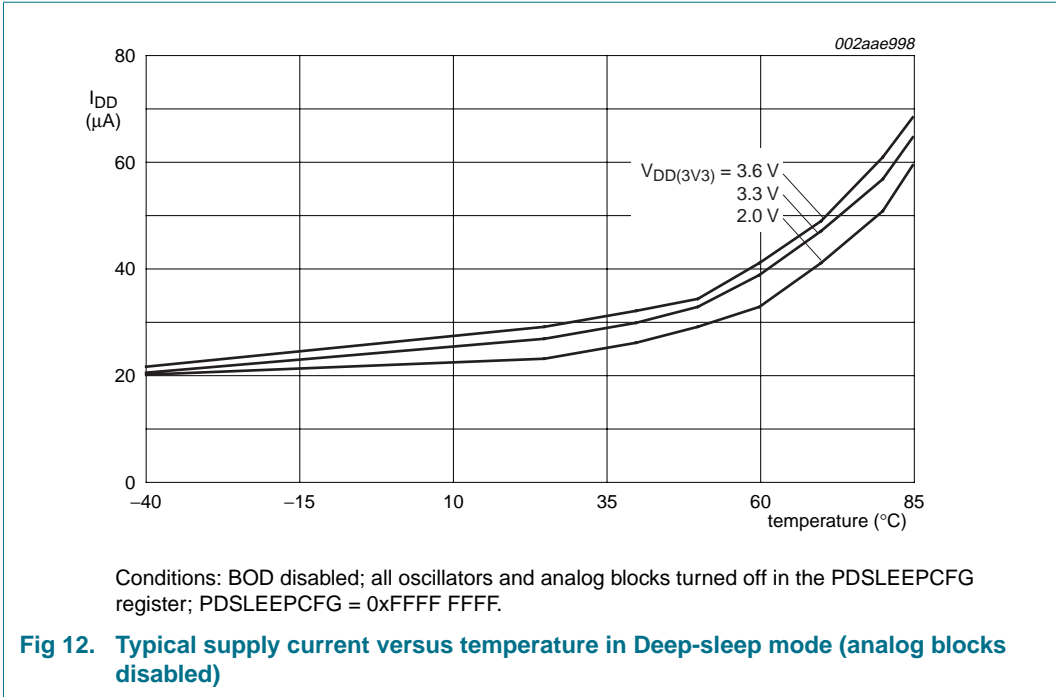

Table 10. Power consumption in Deep-sleep mode for individual analog blocks

$T_{amb} = 25\text{ }^{\circ}\text{C}$; $V_{DD(3V3)} = 3.3\text{ V}$.

Analog block enabled in PDSLEEPCFG register	Conditions	Typical I_{DD} ^[1]
USB PLL	[2]	39 μA
System PLL	[2]	39 μA
System oscillator	[2]	197 μA
BOD	[2]	74 μA
IRC	[2]	36 μA
IRC output	[2]	27 μA

[1] Typical ratings are not guaranteed. The values listed are at room temperature (25 °C), nominal supply voltages.

[2] All other blocks disabled in the PDSLEEPCFG register.

9.3 Electrical pin characteristics

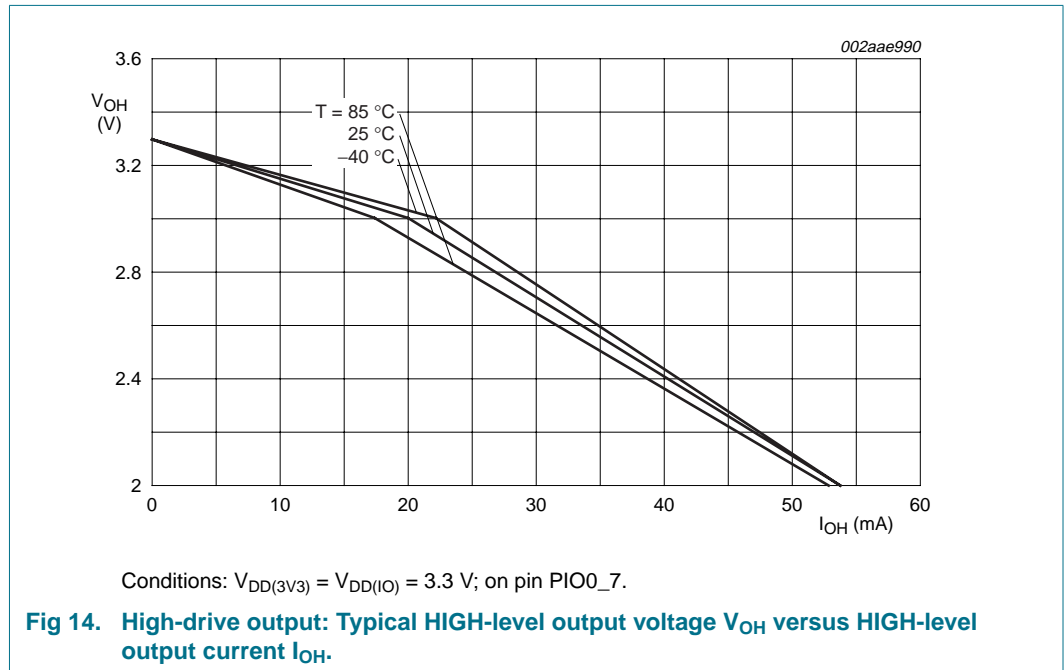

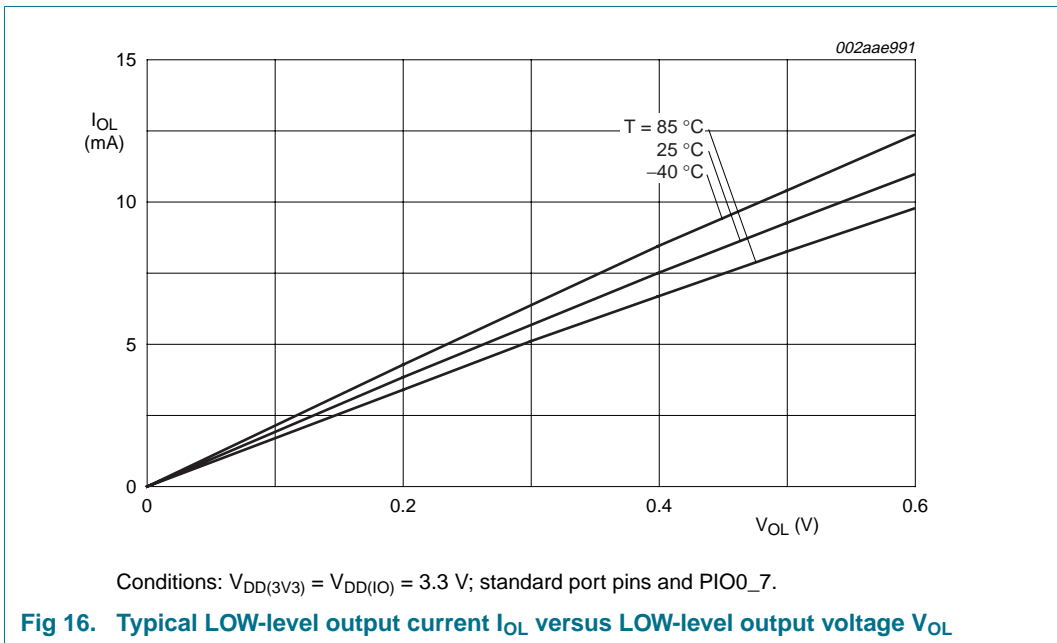
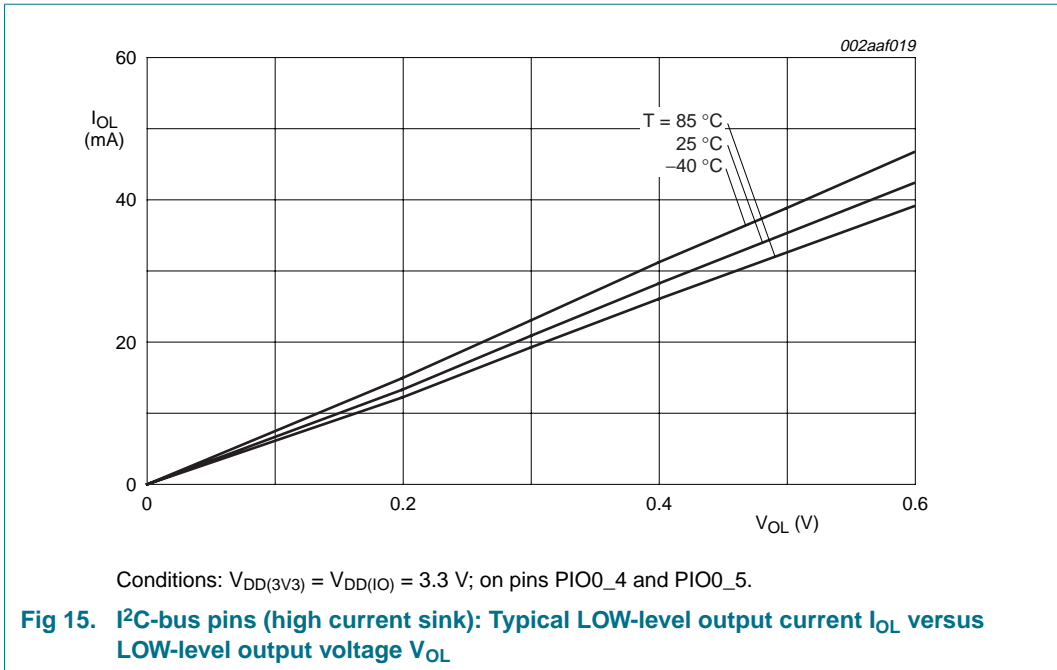

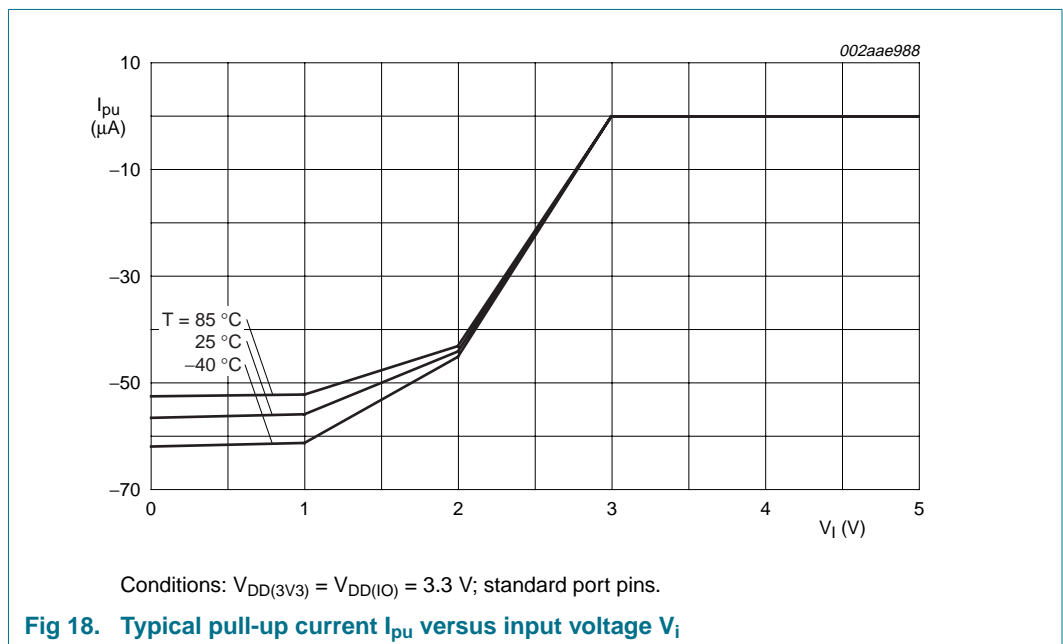
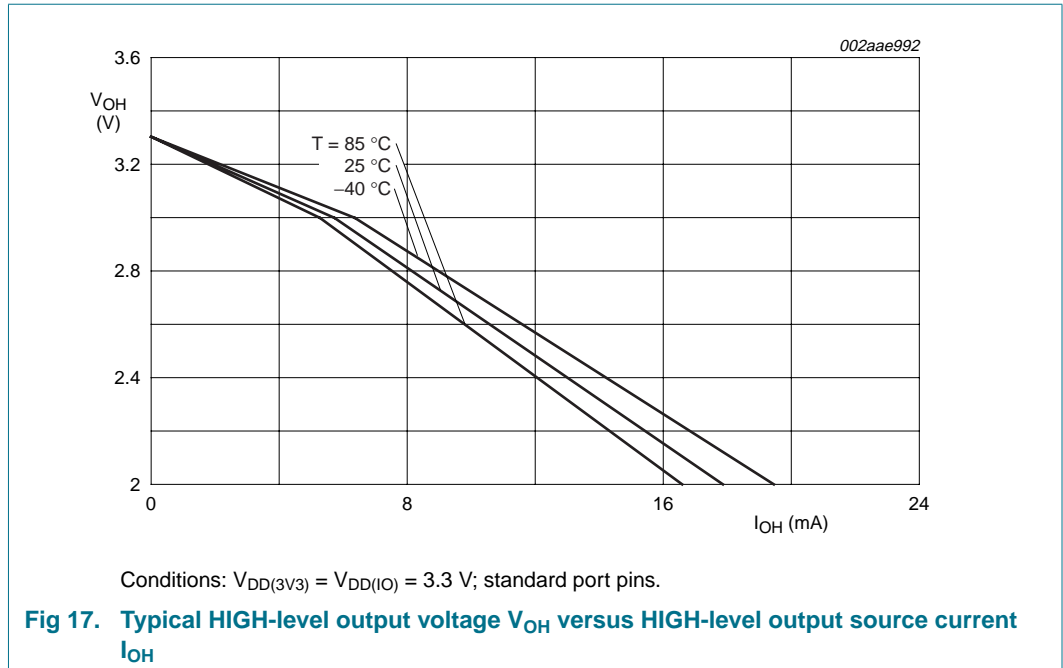

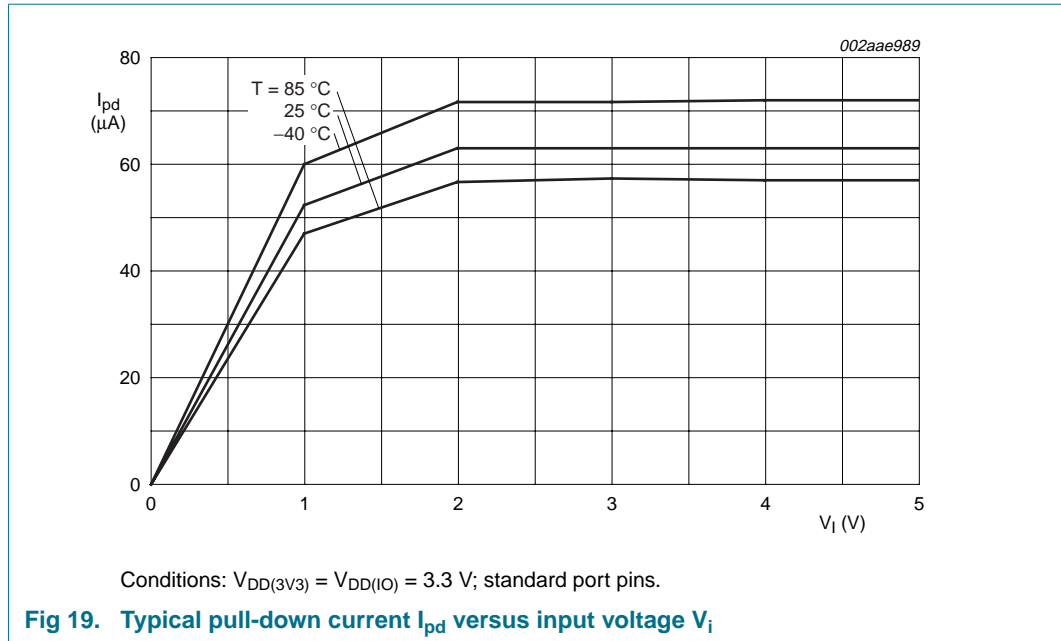

10. Dynamic characteristics

10.1 Flash memory

Table 11. Flash characteristics

$T_{amb} = -40\text{ }^{\circ}\text{C}$ to $+85\text{ }^{\circ}\text{C}$, unless otherwise specified.

Symbol	Parameter	Conditions	Min	Typ	Max	Unit
N_{endu}	endurance		[1] 10000	-	-	cycles
t_{ret}	retention time	powered	10	-	-	years
		unpowered	20	-	-	years

[1] Number of program/erase cycles.

10.2 External clock

Table 12. Dynamic characteristic: external clock

$T_{amb} = -40\text{ }^{\circ}\text{C}$ to $+85\text{ }^{\circ}\text{C}$; $V_{DD(3V3)}$ over specified ranges.[1]

Symbol	Parameter	Conditions	Min	Typ[2]	Max	Unit
f_{osc}	oscillator frequency		1	-	25	MHz
$T_{cy(clk)}$	clock cycle time		40	-	1000	ns
t_{CHCX}	clock HIGH time		$T_{cy(clk)} \times 0.4$	-	-	ns
t_{CLCX}	clock LOW time		$T_{cy(clk)} \times 0.4$	-	-	ns
t_{CLCH}	clock rise time		-	-	5	ns
t_{CHCL}	clock fall time		-	-	5	ns

[1] Parameters are valid over operating temperature range unless otherwise specified.

[2] Typical ratings are not guaranteed. The values listed are at room temperature (25 °C), nominal supply voltages.

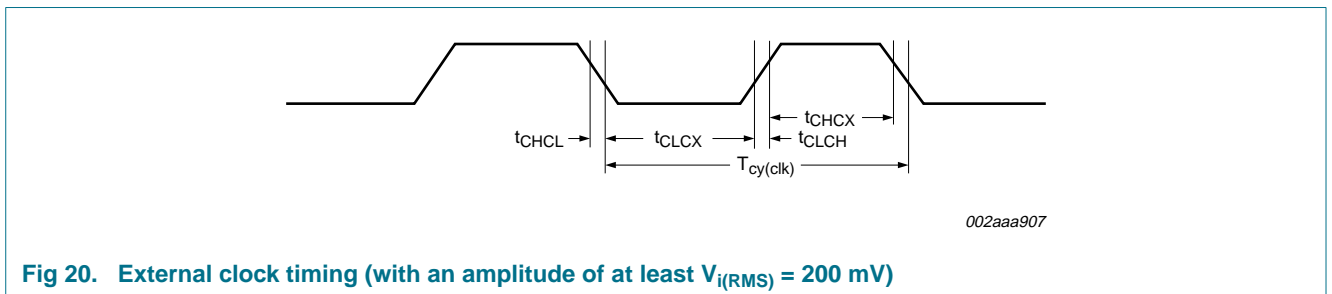

Fig 20. External clock timing (with an amplitude of at least $V_{i(RMS)} = 200\text{ mV}$)

10.3 Internal oscillators

Table 13. Dynamic characteristic: internal oscillators

$T_{amb} = -40\text{ }^{\circ}\text{C}$ to $+85\text{ }^{\circ}\text{C}$; $2.7\text{ V} \leq V_{DD(3V3)} \leq 3.6\text{ V}$ [1].

Symbol	Parameter	Conditions	Min	Typ[2]	Max	Unit
$f_{osc(RC)}$	internal RC oscillator frequency	-	11.88	12	12.12	MHz

- [1] Parameters are valid over operating temperature range unless otherwise specified.
- [2] Typical ratings are not guaranteed. The values listed are at room temperature (25 °C), nominal supply voltages.

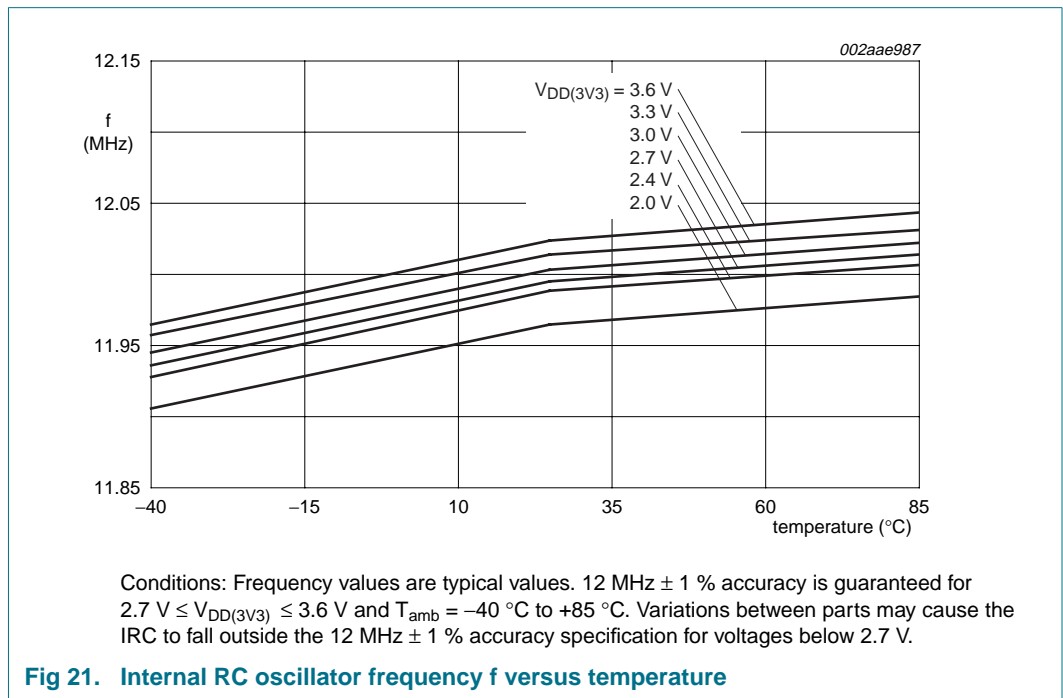

Fig 21. Internal RC oscillator frequency f versus temperature

10.4 I²C-bus

Table 14. Dynamic characteristic: I²C-bus pins (Fast-mode Plus)

$T_{amb} = -40\text{ }^{\circ}\text{C}$ to $+85\text{ }^{\circ}\text{C}$; $V_{DD(3V3)} = V_{DD(I/O)} = 3.3\text{ V}$. [1][2][3]

Symbol	Parameter	Conditions	Min	Typ	Max	Unit
f_{SCL}	SCL clock frequency	-	-	-	1	MHz
t_f	fall time	-	-	-	45	ns
$t_{SU;DAT}$	data set-up time	-	50	-	-	ns

- [1] Parameters are valid over operating temperature range unless otherwise specified.
- [2] Main clock frequency 10 MHz; system clock divider AHBCLKDIV = 0x1; I²C-bus interface configured in master mode.
- [3] Bus capacitance C_b = 550 pF; external pull-up resistance of 103 Ω.

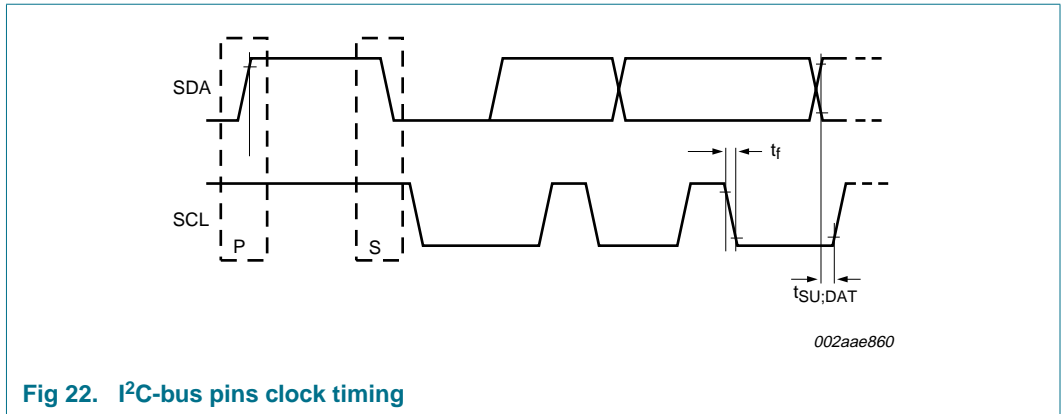

Fig 22. I²C-bus pins clock timing

10.5 SSP interface

Table 15. Dynamic characteristics of SSP pins in SPI mode

Symbol	Parameter	Conditions	Min	Max	Unit
T _{cy(PCLK)}	PCLK cycle time		13.9	-	ns
T _{cy(clk)}	clock cycle time	[1]	27.8	-	ns
SSP master					
t _{DS}	data set-up time	in SPI mode	[2] 15	T _{cy(clk)}	ns
t _{DH}	data hold time	in SPI mode	[2] -	0	ns
t _{v(Q)}	data output valid time	in SPI mode	[2] -	10	ns
t _{h(Q)}	data output hold time	in SPI mode	[2] -	0	ns
SSP slave					
t _{DS}	data set-up time	in SPI mode	[3][4] 0	-	ns
t _{DH}	data hold time	in SPI mode	[3][4] 3 × T _{cy(PCLK)} + 4	-	ns
t _{v(Q)}	data output valid time	in SPI mode	[3][4] -	3 × T _{cy(PCLK)} + 11	ns
t _{h(Q)}	data output hold time	in SPI mode	[3][4] -	2 × T _{cy(PCLK)} + 5	ns

[1] $T_{cy(clk)} = (SSPCLKDIV \times (1 + SCR) \times CPSDVSR) / f_{main}$. The clock cycle time derived from the SPI bit rate T_{cy(clk)} is a function of the main clock frequency f_{main}, the SSP peripheral clock divider (SSPCLKDIV), the SSP SCR parameter (specified in the SSP0CR0 register), and the SSP CPSDVSR parameter (specified in the SSP clock prescale register).

[2] T_{amb} = -40 °C to 85 °C; V_{DD(3V3)} = 2.0 V to 3.6 V; V_{DD(I/O)} = 2.0 V to 3.6 V.

[3] T_{cy(clk)} = 12 × T_{cy(PCLK)}.

[4] T_{amb} = 25 °C; V_{DD(3V3)} = 3.3 V; V_{DD(I/O)} = 3.3 V.

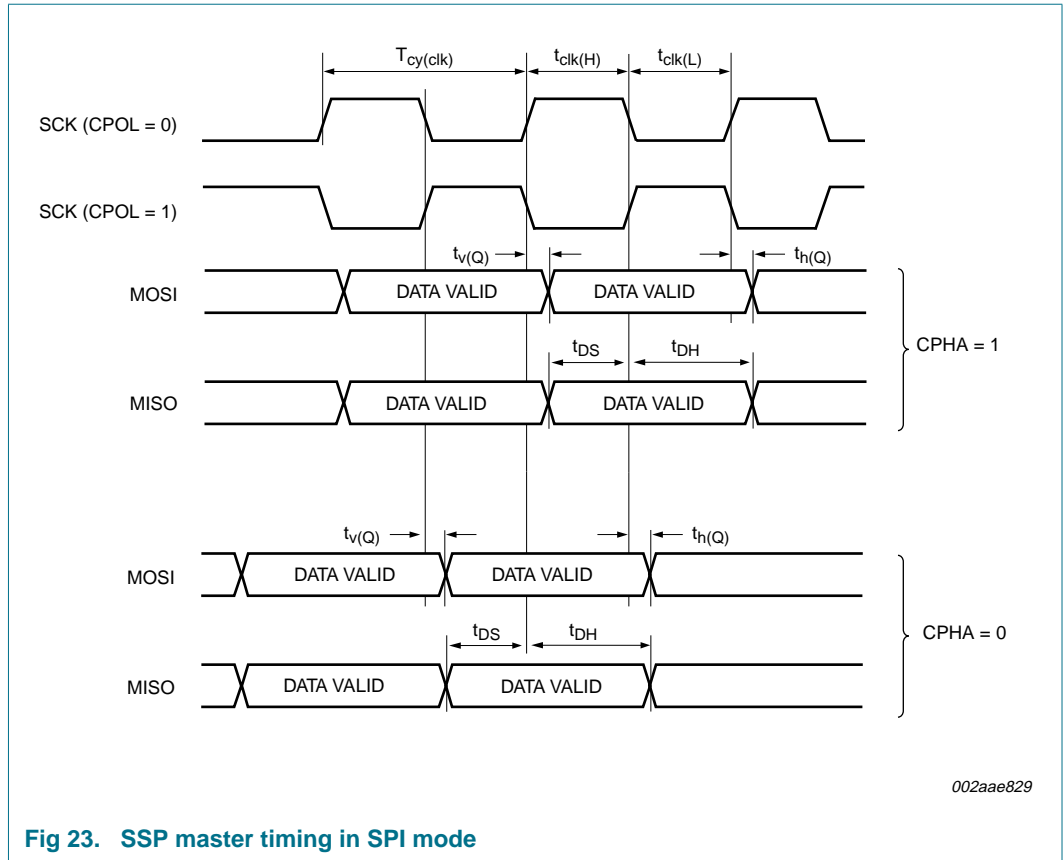

Fig 23. SSP master timing in SPI mode

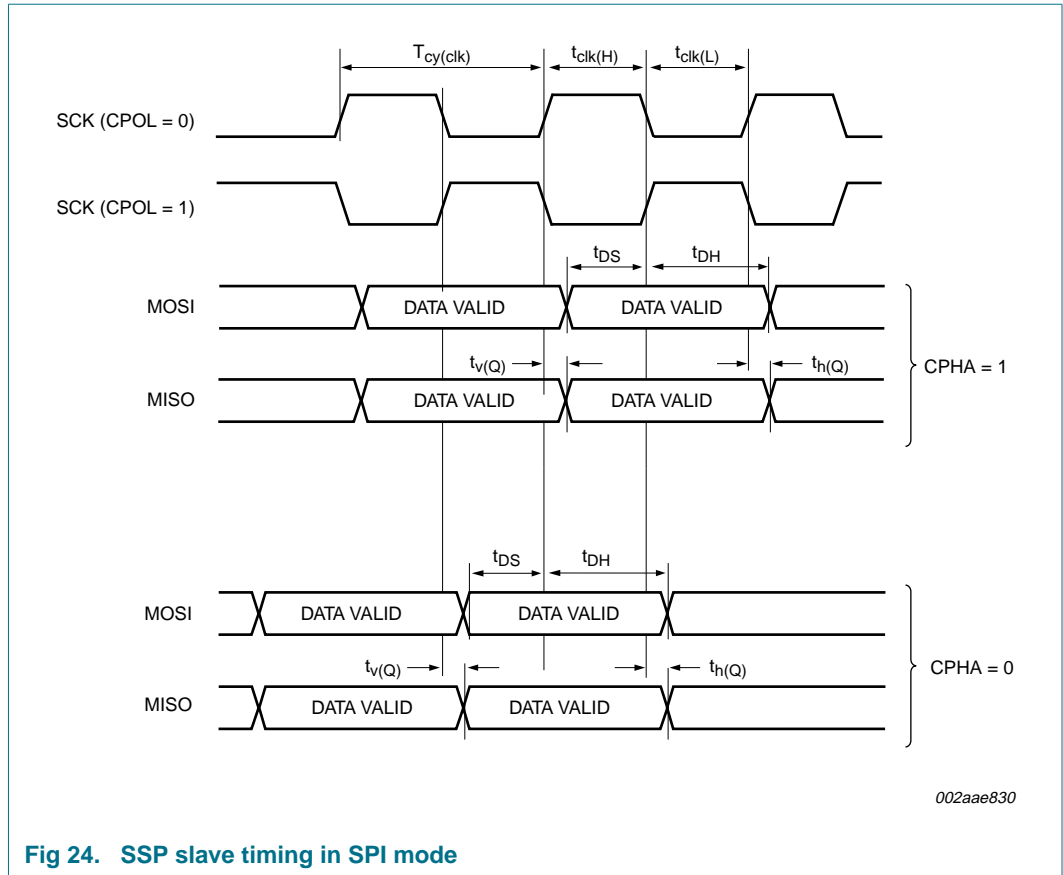

Fig 24. SSP slave timing in SPI mode

10.6 USB interface (LPC1342/43 only)

Table 16. Dynamic characteristics: USB pins (full-speed)

$C_L = 50\text{ pF}$; $R_{pu} = 1.5\text{ k}\Omega$ on D+ to $V_{DD(3V3)}$, unless otherwise specified.

Symbol	Parameter	Conditions	Min	Typ	Max	Unit
t_r	rise time	10 % to 90 %	8.5	-	13.8	ns
t_f	fall time	10 % to 90 %	7.7	-	13.7	ns
t_{FRFM}	differential rise and fall time matching	t_r / t_f	-	-	109	%
V_{CRS}	output signal crossover voltage		1.3	-	2.0	V
t_{FEOPT}	source SE0 interval of EOP	see Figure 25	160	-	175	ns
t_{FDEOP}	source jitter for differential transition to SE0 transition	see Figure 25	-2	-	+5	ns
t_{JR1}	receiver jitter to next transition		-18.5	-	+18.5	ns
t_{JR2}	receiver jitter for paired transitions	10 % to 90 %	-9	-	+9	ns
t_{EOPR1}	EOP width at receiver	must reject as EOP; see Figure 25	[1] 40	-	-	ns
t_{EOPR2}	EOP width at receiver	must accept as EOP; see Figure 25	[1] 82	-	-	ns

[1] Characterized but not implemented as production test. Guaranteed by design.

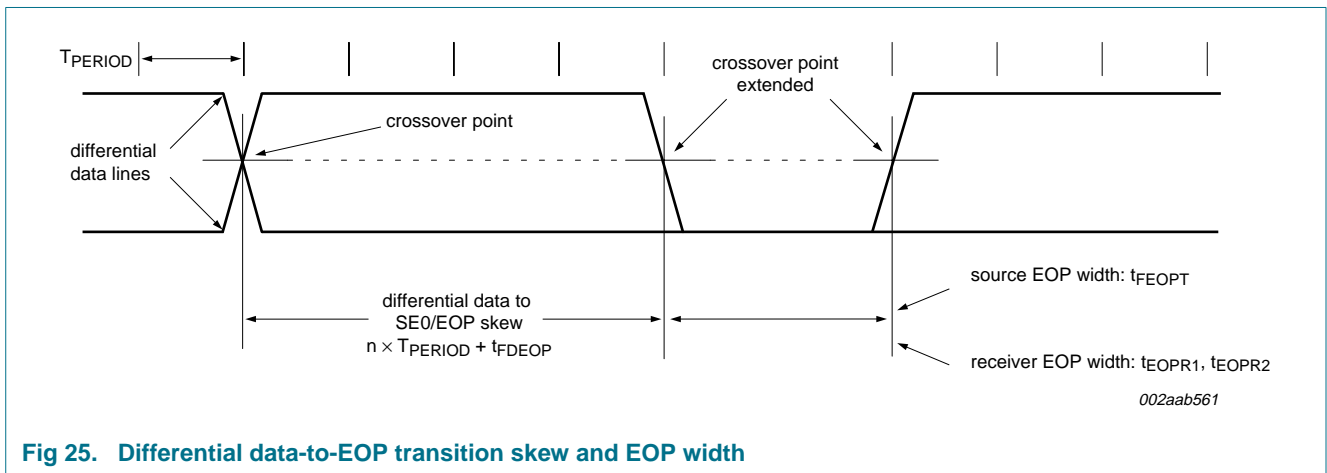
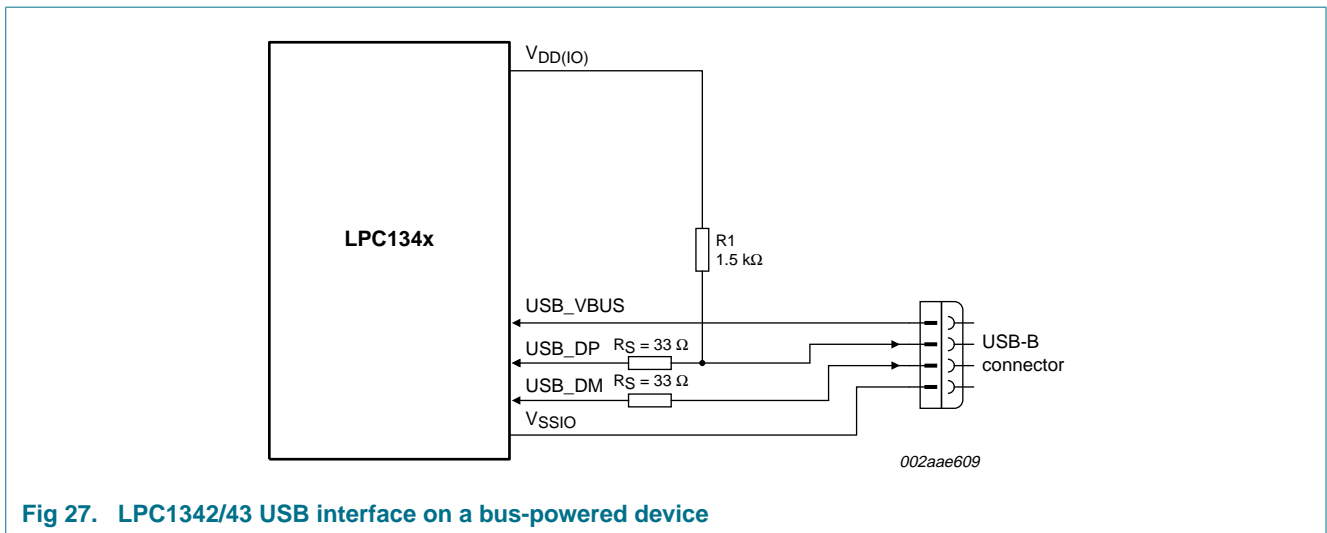
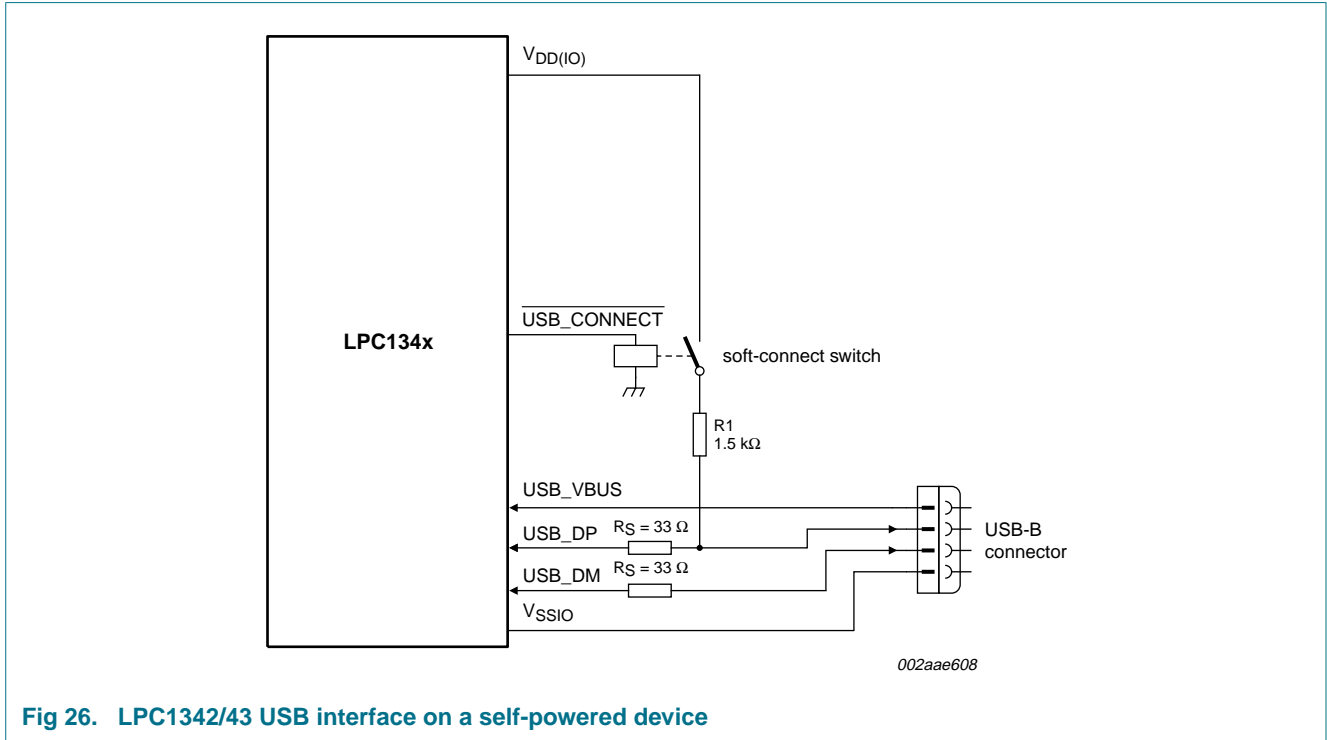

Fig 25. Differential data-to-EOP transition skew and EOP width

11. Application information

11.1 Suggested USB interface solutions (LPC1342/43 only)



11.2 XTAL input

The input voltage to the on-chip oscillators is limited to 1.8 V. If the oscillator is driven by a clock in slave mode, it is recommended that the input be coupled through a capacitor with $C_i = 100$ pF. To limit the input voltage to the specified range, choose an additional capacitor to ground C_g which attenuates the input voltage by a factor $C_i / (C_i + C_g)$. In slave mode, a minimum of 200 mV(RMS) is needed.

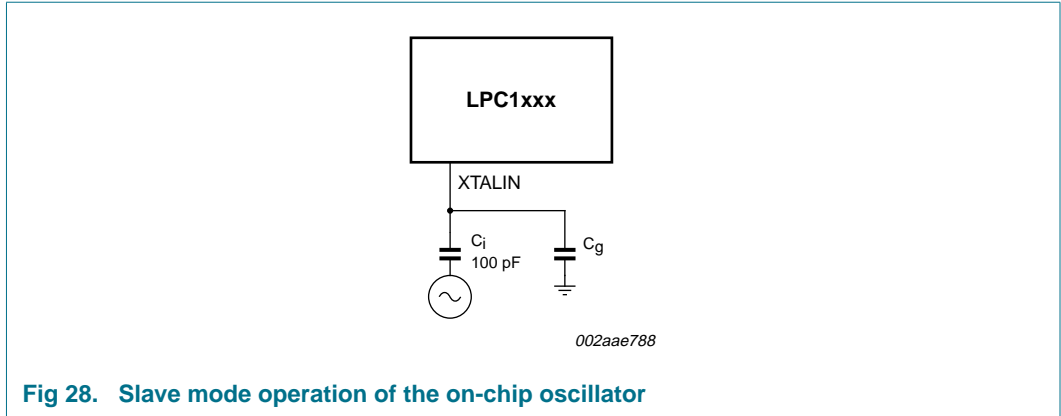

Fig 28. Slave mode operation of the on-chip oscillator

11.3 XTAL Printed-Circuit Board (PCB) layout guidelines

The crystal should be connected on the PCB as close as possible to the oscillator input and output pins of the chip. Take care that the load capacitors C_{x1} , C_{x2} , and C_{x3} in case of third overtone crystal usage have a common ground plane. The external components must also be connected to the ground plain. Loops must be made as small as possible in order to keep the noise coupled in via the PCB as small as possible. Also parasitics should stay as small as possible. Values of C_{x1} and C_{x2} should be chosen smaller accordingly to the increase in parasitics of the PCB layout.

11.4 Standard I/O pad configuration

Figure 29 shows the possible pin modes for standard I/O pins. The pull-up and pull-down resistors (R_{pu} and R_{pd}) can be enabled or disabled. The default value for each standard port pin is input with R_{pu} enabled. For details on pin modes and hysteresis control, see the *LPC13xx user manual*.

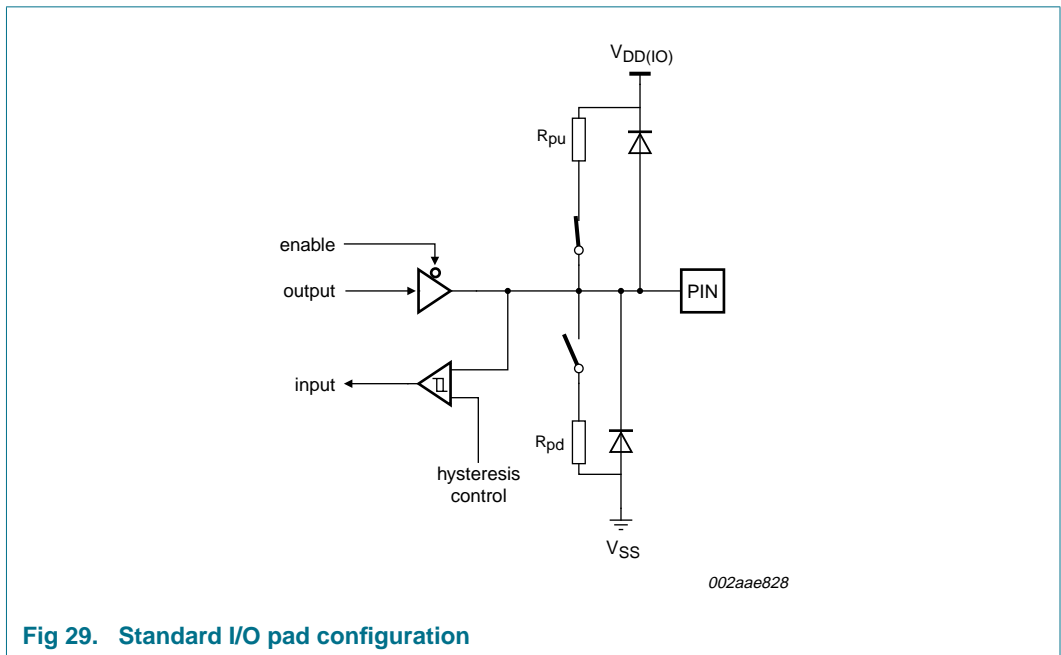

Fig 29. Standard I/O pad configuration

12. Package outline

LQFP48: plastic low profile quad flat package; 48 leads; body 7 x 7 x 1.4 mm

SOT313-2

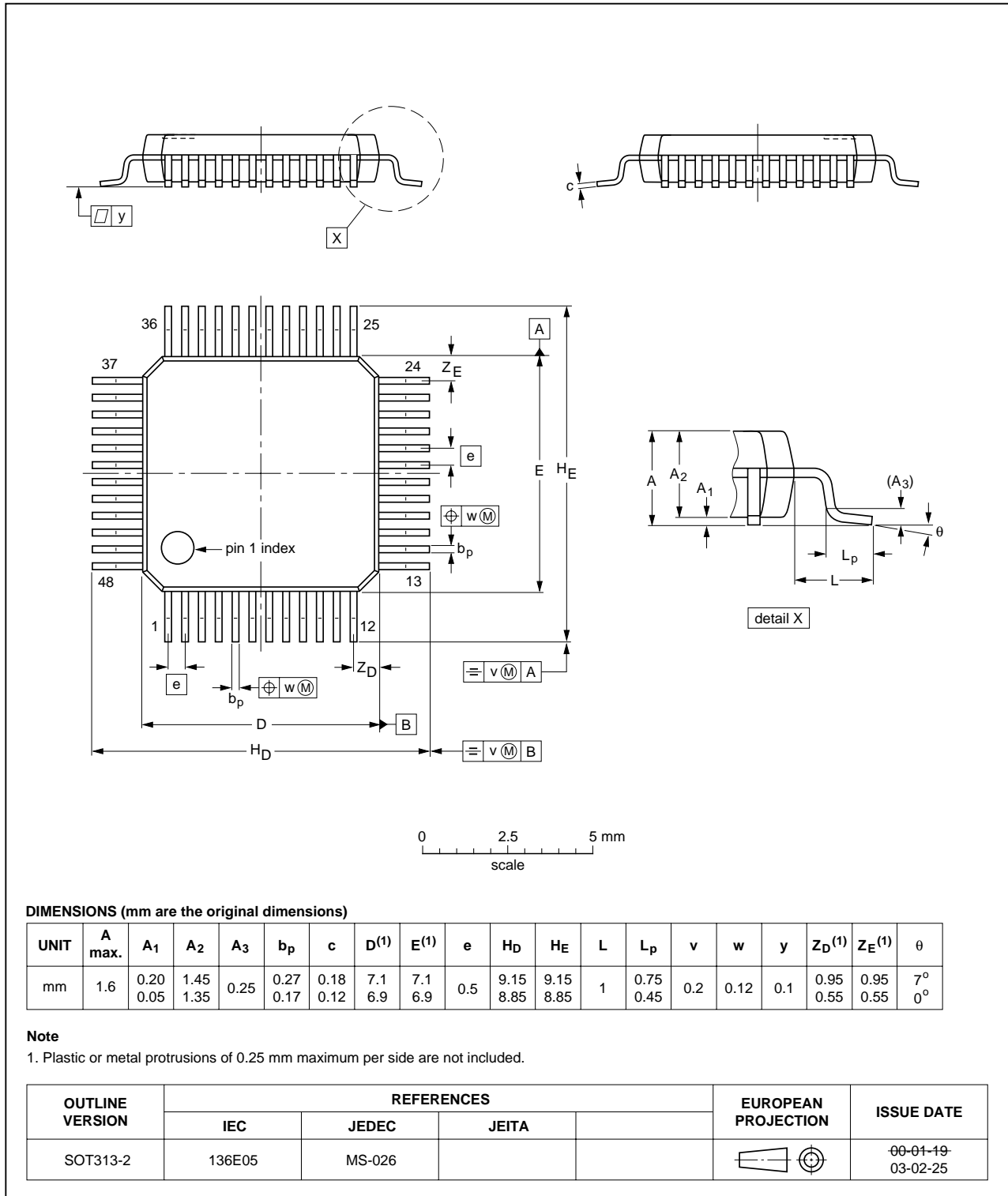

Fig 30. Package outline SOT313-2 (LQFP48)

**HVQFN33: plastic thermal enhanced very thin quad flat package; no leads;
33 terminals; body 7 x 7 x 0.85 mm**

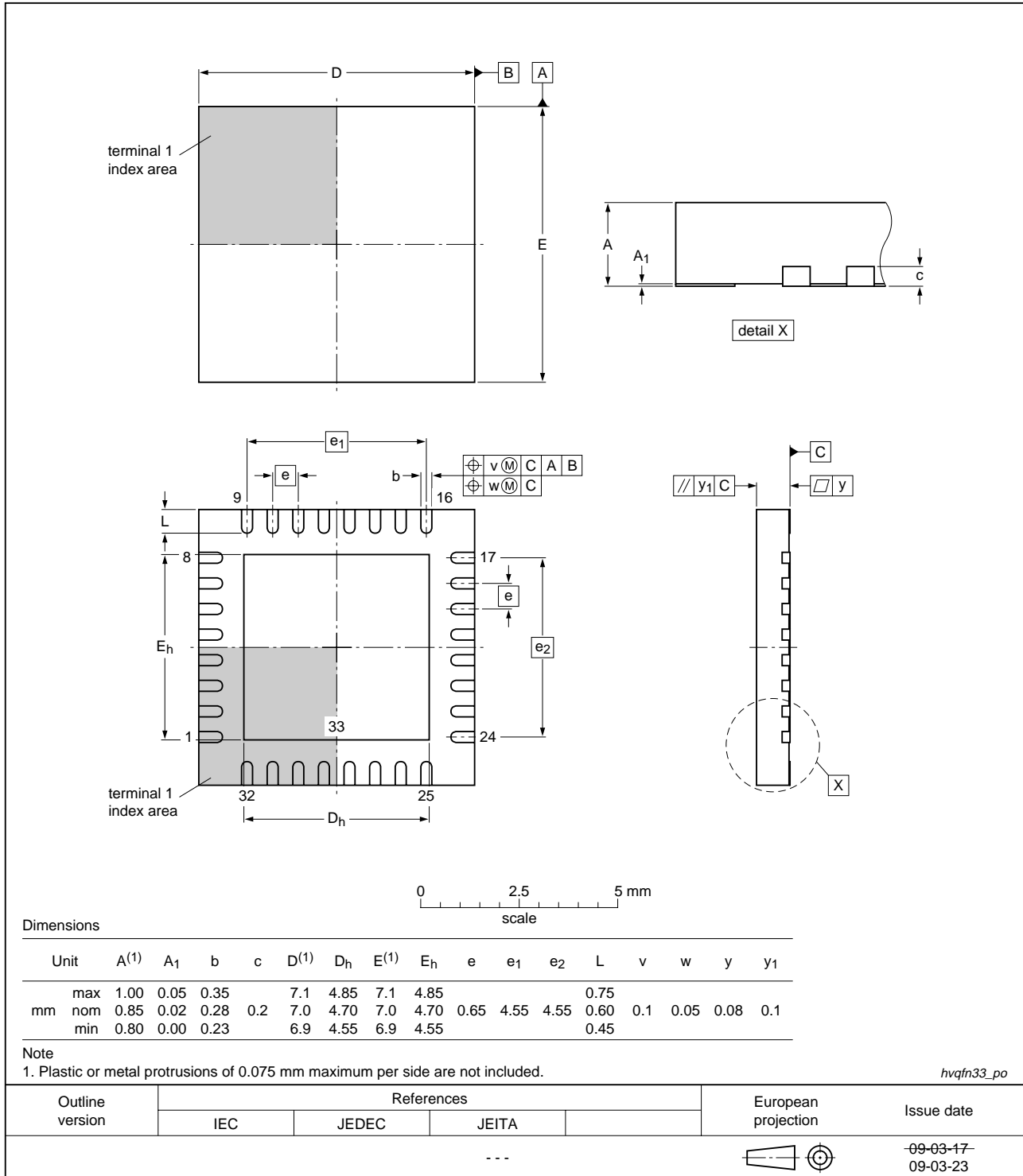

Fig 31. Package outline (HVQFN33)

13. Abbreviations

Table 17. Abbreviations

Acronym	Description
A/D	Analog-to-Digital
ADC	Analog-to-Digital Converter
AHB	Advanced High-performance Bus
AMBA	Advanced Microcontroller Bus Architecture
APB	Advanced Peripheral Bus
BOD	BrownOut Detection
EOP	End Of Packet
ETM	Embedded Trace Macrocell
FIFO	First-In, First-Out
GPIO	General Purpose Input/Output
I/O	Input/Output
LSB	Least Significant Bit
MSC	Mass Storage Class
PHY	Physical Layer
PLL	Phase-Locked Loop
SE0	Single Ended Zero
SPI	Serial Peripheral Interface
SSI	Serial Synchronous Interface
SSP	Synchronous Serial Port
SoF	Start-of-Frame
TCM	Tightly-Coupled Memory
TTL	Transistor-Transistor Logic
UART	Universal Asynchronous Receiver/Transmitter
USB	Universal Serial Bus

14. Revision history

Table 18. Revision history

Document ID	Release date	Data sheet status	Change notice	Supersedes
LPC1311_13_42_43_1	20091211	Product data sheet	-	-

15. Legal information

15.1 Data sheet status

Document status ^{[1][2]}	Product status ^[3]	Definition
Objective [short] data sheet	Development	This document contains data from the objective specification for product development.
Preliminary [short] data sheet	Qualification	This document contains data from the preliminary specification.
Product [short] data sheet	Production	This document contains the product specification.

[1] Please consult the most recently issued document before initiating or completing a design.

[2] The term 'short data sheet' is explained in section "Definitions".

[3] The product status of device(s) described in this document may have changed since this document was published and may differ in case of multiple devices. The latest product status information is available on the Internet at URL <http://www.nxp.com>.

15.2 Definitions

Draft — The document is a draft version only. The content is still under internal review and subject to formal approval, which may result in modifications or additions. NXP Semiconductors does not give any representations or warranties as to the accuracy or completeness of information included herein and shall have no liability for the consequences of use of such information.

Short data sheet — A short data sheet is an extract from a full data sheet with the same product type number(s) and title. A short data sheet is intended for quick reference only and should not be relied upon to contain detailed and full information. For detailed and full information see the relevant full data sheet, which is available on request via the local NXP Semiconductors sales office. In case of any inconsistency or conflict with the short data sheet, the full data sheet shall prevail.

15.3 Disclaimers

General — Information in this document is believed to be accurate and reliable. However, NXP Semiconductors does not give any representations or warranties, expressed or implied, as to the accuracy or completeness of such information and shall have no liability for the consequences of use of such information.

Right to make changes — NXP Semiconductors reserves the right to make changes to information published in this document, including without limitation specifications and product descriptions, at any time and without notice. This document supersedes and replaces all information supplied prior to the publication hereof.

Suitability for use — NXP Semiconductors products are not designed, authorized or warranted to be suitable for use in medical, military, aircraft, space or life support equipment, nor in applications where failure or malfunction of an NXP Semiconductors product can reasonably be expected to result in personal injury, death or severe property or environmental

damage. NXP Semiconductors accepts no liability for inclusion and/or use of NXP Semiconductors products in such equipment or applications and therefore such inclusion and/or use is at the customer's own risk.

Applications — Applications that are described herein for any of these products are for illustrative purposes only. NXP Semiconductors makes no representation or warranty that such applications will be suitable for the specified use without further testing or modification.

Limiting values — Stress above one or more limiting values (as defined in the Absolute Maximum Ratings System of IEC 60134) may cause permanent damage to the device. Limiting values are stress ratings only and operation of the device at these or any other conditions above those given in the Characteristics sections of this document is not implied. Exposure to limiting values for extended periods may affect device reliability.

Terms and conditions of sale — NXP Semiconductors products are sold subject to the general terms and conditions of commercial sale, as published at <http://www.nxp.com/profile/terms>, including those pertaining to warranty, intellectual property rights infringement and limitation of liability, unless explicitly otherwise agreed to in writing by NXP Semiconductors. In case of any inconsistency or conflict between information in this document and such terms and conditions, the latter will prevail.

No offer to sell or license — Nothing in this document may be interpreted or construed as an offer to sell products that is open for acceptance or the grant, conveyance or implication of any license under any copyrights, patents or other industrial or intellectual property rights.

Export control — This document as well as the item(s) described herein may be subject to export control regulations. Export might require a prior authorization from national authorities.

15.4 Trademarks

Notice: All referenced brands, product names, service names and trademarks are the property of their respective owners.

I²C-bus — logo is a trademark of NXP B.V.

16. Contact information

For more information, please visit: <http://www.nxp.com>

For sales office addresses, please send an email to: salesaddresses@nxp.com

17. Contents

1	General description	1	7.17.5.1	Sleep mode	24
2	Features	1	7.17.5.2	Deep-sleep mode	24
3	Applications	2	7.17.5.3	Deep power-down mode	24
4	Ordering information	3	7.18	System control	24
4.1	Ordering options	3	7.18.1	Reset	24
5	Block diagram	4	7.18.2	Brownout detection	25
6	Pinning information	5	7.18.3	Code security (Code Read Protection - CRP)	25
6.1	Pinning	5	7.18.4	Boot loader	25
6.2	Pin description	8	7.18.5	APB interface	26
7	Functional description	14	7.18.6	AHB-Lite	26
7.1	Architectural overview	14	7.18.7	External interrupt inputs	26
7.2	ARM Cortex-M3 processor	14	7.18.8	Memory mapping control	26
7.3	On-chip flash program memory	15	7.19	Emulation and debugging	26
7.4	On-chip SRAM	15	8	Limiting values	27
7.5	Memory map	15	9	Static characteristics	28
7.6	Nested Vectored Interrupt Controller (NVIC)	16	9.1	BOD static characteristics	33
7.6.1	Features	16	9.2	Power consumption	33
7.6.2	Interrupt sources	17	9.3	Electrical pin characteristics	36
7.7	IOCONFIG block	17	10	Dynamic characteristics	40
7.8	Fast general purpose parallel I/O	17	10.1	Flash memory	40
7.8.1	Features	17	10.2	External clock	40
7.9	USB interface (LPC1342/43 only)	18	10.3	Internal oscillators	41
7.9.1	Full-speed USB device controller	18	10.4	I ² C-bus	41
7.9.1.1	Features	18	10.5	SSP interface	42
7.10	UART	18	10.6	USB interface (LPC1342/43 only)	45
7.10.1	Features	19	11	Application information	46
7.11	SSP serial I/O controller	19	11.1	Suggested USB interface solutions (LPC1342/43 only)	46
7.11.1	Features	19	11.2	XTAL input	46
7.12	I ² C-bus serial I/O controller	19	11.3	XTAL Printed-Circuit Board (PCB) layout guidelines	47
7.12.1	Features	19	11.4	Standard I/O pad configuration	47
7.13	10-bit ADC	20	12	Package outline	48
7.13.1	Features	20	13	Abbreviations	50
7.14	General purpose external event counters/timers	20	14	Revision history	51
7.14.1	Features	20	15	Legal information	52
7.15	System tick timer	21	15.1	Data sheet status	52
7.16	Watchdog timer	21	15.2	Definitions	52
7.16.1	Features	21	15.3	Disclaimers	52
7.17	Clocking and power control	21	15.4	Trademarks	52
7.17.1	Crystal oscillators	21	16	Contact information	52
7.17.1.1	Internal RC oscillator	22	17	Contents	53
7.17.1.2	System oscillator	23			
7.17.2	System PLL and USB PLL	23			
7.17.3	Clock output	23			
7.17.4	Wake-up process	23			
7.17.5	Power control	23			

Please be aware that important notices concerning this document and the product(s) described herein, have been included in section 'Legal information'.

