

High Speed Switching Diode

1SS388

FEATURES

- Low forward voltage.
- Low reverse current.
- Small package.

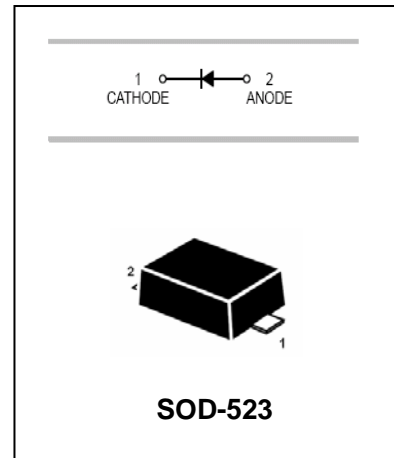

APPLICATIONS

- High-speed switching in surface mounted circuits.

ORDERING INFORMATION

Type No.	Marking	Package Code
1SS388	S3	SOD-523

MAXIMUM RATING @ Ta=25°C unless otherwise specified

Parameter	Symbol	Limits	Unit
Peak reverse voltage	V_{RM}	45	V
DC Reverse voltage	V_R	40	V
Continuous forward current	I_F	100	mA
Surge current	I_{FSM}	1	A
Total power dissipation	P_{tot}	150	mW
Junction temperature	T_j	125	°C
Storage temperature	T_{stg}	-55-125	°C

ELECTRICAL CHARACTERISTICS @ Ta=25°C unless otherwise specified

Parameter	Symbol	Min.	Typ.	Max.	Unit	Conditions
Forward voltage	V_F		0.28		V	$I_F=1mA$
			0.36		V	$I_F=10mA$
			0.54	0.60	V	$I_F=50mA$
Reverse current	I_R			5	μA	$V_R=10V$
Diode capacitance	C_d		18	25	pF	$V_R=0, f=1MHz$

High Speed Switching Diode

1SS388

TYPICAL CHARACTERISTICS @ $T_a=25^\circ\text{C}$ unless otherwise specified

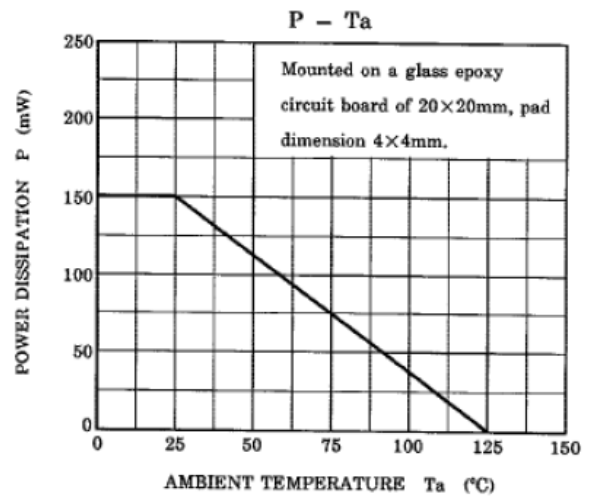
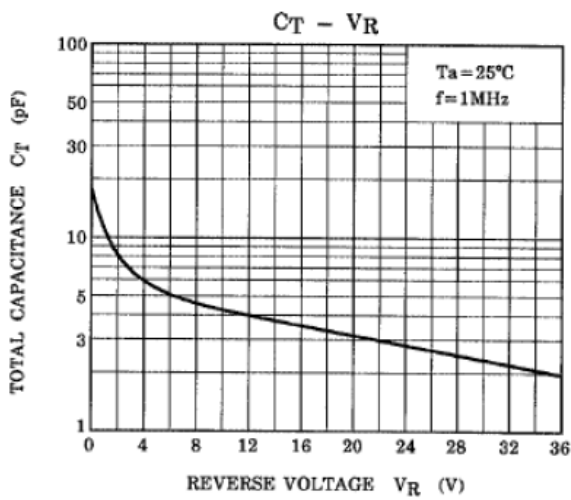
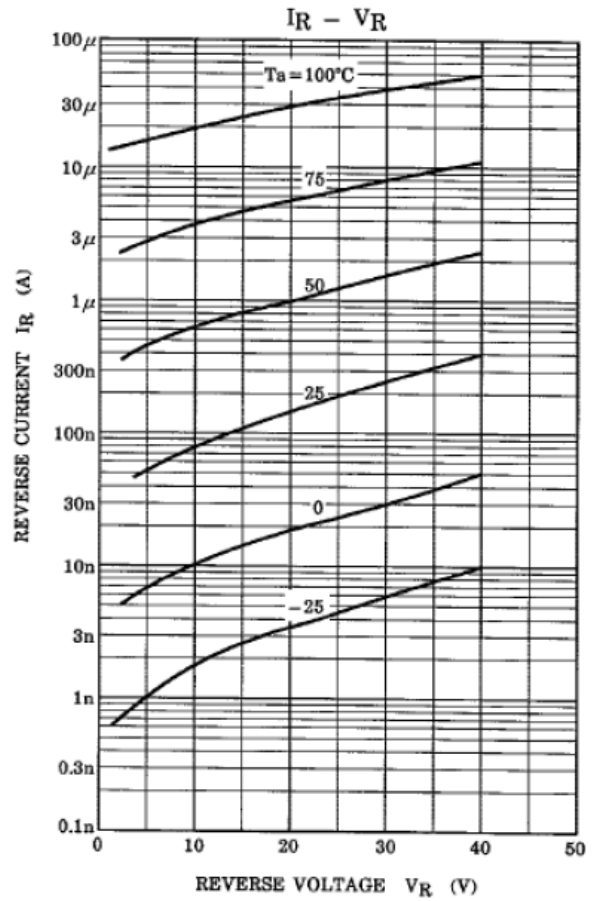
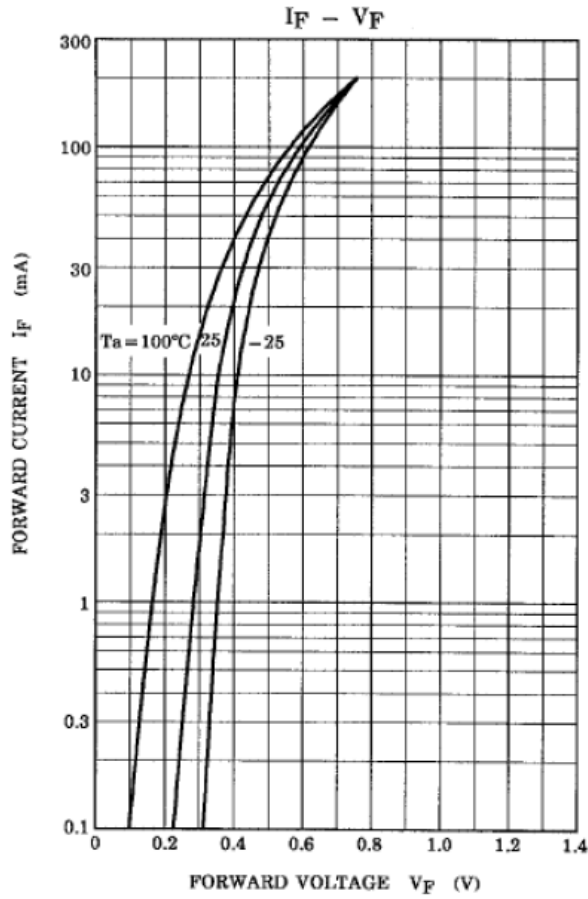

High Speed Switching Diode

1SS388

PACKAGE OUTLINE

Plastic surface mounted package

SOD-523

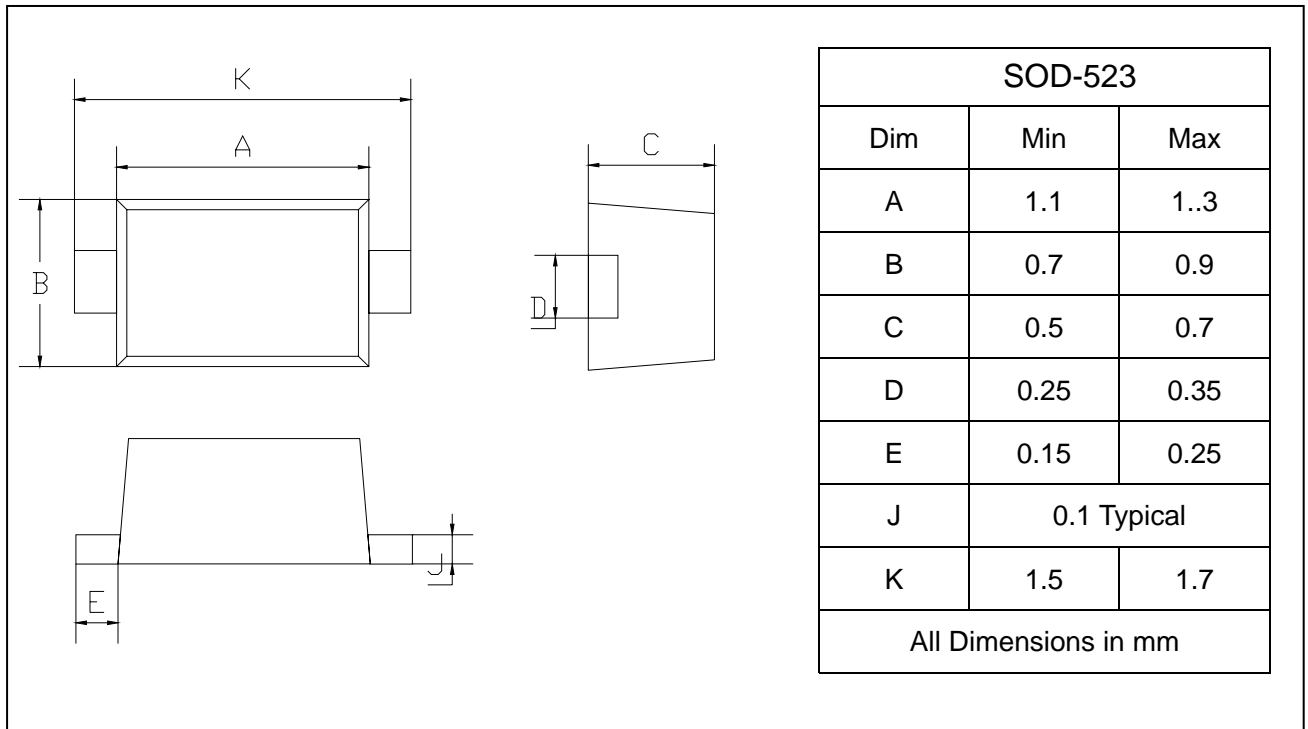

SOLDERING FOOTPRINT

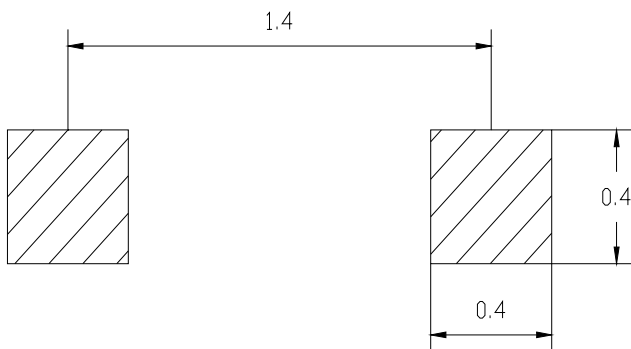

Unit: mm

PACKAGE INFORMATION

Device	Package	Shipping
1SS388	SOD-523	3000/Tape&Reel