

800mA BTL Linear Fan Motor Driver

DESCRIPTION

EUM6883 is a single-phase full wave DC fan motor driver. It is used as an interface between a HALL IC and a single coil brushless motor. With its BTL linear control and low saturation output stages, EUM6883 silently and efficiently drives a fan motor. The functions built in EUM6883 are linear control drive mode, fan tachometer, lock detection, automatic restart, Hall Bias and thermal shutdown. When output voltage changes from L to H (or H to L), linear control mode gently drives the output stage. This makes EUM6883 suitable for the electronics equipment which required low noise and high reliability. If the motor is stalled by the external force, overdrive current may incur coil overheat or burning. To prevent this, the lock detection circuit shuts off the driver. The automatic restart circuit resumes powering up the driver after a few seconds. Rotation detection open drain output is pulled down when a motor runs. FG is the Fan tachometer output, and HB provides bias supply for a Hall sensor.

FEATURES

- Linear Control for Single-Phase Full Wave Drive
- Wide Input Range 1.8V~13.8V
- Low Saturation Output Voltage 0.5V @250mA
- FG Tachometer Output
- Lock Detection, Automatic Restart
 - RD = L when Rotation; RD = H when Stop
- 1.5V Hall Bias
- Thermal Shutdown Protection
- Available in MSOP-10 Package
- RoHS Compliant and 100% Lead (Pb)-Free

APPLICATIONS

- CPU Cooling Fan
- Car Audio Cooler
- Power Supply Cooling Fan

Block Diagram

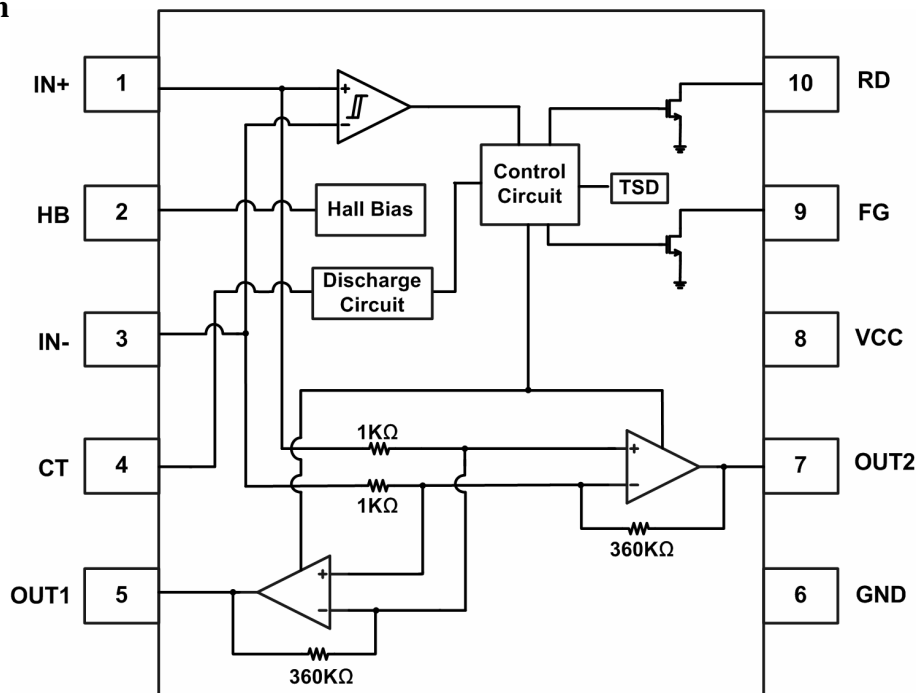

Figure 1.