

## FR2TSMA ... FR2YSMA

### Fast Switching Surface Mount Si-Rectifiers Schnelle Si-Gleichrichter für die Oberflächenmontage

Version 2006-01-27

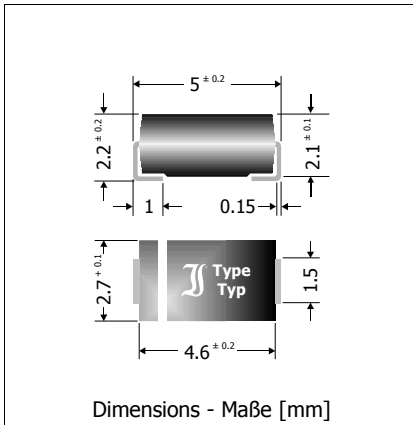

Nominal current – Nennstrom	2 A
Repetitive peak reverse voltage Periodische Spitzensperrspannung	1300...2000 V
Plastic case Kunststoffgehäuse	~ SMA ~ DO-214AC
Weight approx. – Gewicht ca.	0.07 g
Plastic material has UL classification 94V-0 Gehäusematerial UL94V-0 klassifiziert	
Standard packaging taped and reeled Standard Lieferform gegurtet auf Rolle	

#### Maximum ratings

#### Grenzwerte

Type Typ	Repetitive peak reverse voltage Periodische Spitzensperrspannung $V_{RRM}$ [V]	Surge peak reverse voltage Stoßspitzensperrspannung $V_{RSM}$ [V]
FR2TSMA	1300	1300
FR2WSMA	1600	1600
FR2XSMA	1800	1800
FR2YSMA	2000	2000

Max. average forward rectified current, R-load Dauergrenzstrom in Einwegschtung mit R-Last	$T_T = 100^\circ\text{C}$	$I_{FAV}$	2 A
Repetitive peak forward current Periodischer Spitzenstrom	$f > 15$ Hz	$I_{FRM}$	10 A <sup>1)</sup>
Peak forward surge current, 50/60 Hz half sine-wave Stoßstrom für eine 50/60 Hz Sinus-Halbwell	$T_A = 25^\circ\text{C}$	$I_{FSM}$	45/50 A
Rating for fusing, $t < 10$ ms Grenzlastintegral, $t < 10$ ms	$T_A = 25^\circ\text{C}$	$i^2t$	12.5 A <sup>2</sup> s
Junction temperature – Sperrschichttemperatur		$T_j$	-50...+150°C
Storage temperature – Lagerungstemperatur		$T_s$	-50...+150°C

1 Mounted on P.C. board with 25 mm<sup>2</sup> copper pads at each terminal  
Montage auf Leiterplatte mit 25 mm<sup>2</sup> Kupferbelag (Löt-pad) an jedem Anschluss

**Characteristics**
**Kenwerte**

Forward voltage Durchlass-Spannung	$T_j = 25^\circ\text{C}$	$I_F = 2\text{ A}$	$V_F$	$< 1.8\text{ V}$
Leakage current Sperrstrom	$T_j = 25^\circ\text{C}$	$V_R = V_{RRM}$	$I_R$	$< 5\ \mu\text{A}$
	$T_j = 100^\circ\text{C}$	$V_R = V_{RRM}$	$I_R$	$< 100\ \mu\text{A}$
Reverse recovery time Sperrverzug	$I_F = 0.5\text{ A}$ through/über		$t_{rr}$	$< 500\text{ ns}$
	$I_R = 1\text{ A}$ to/auf $I_R = 0.25\text{ A}$			
Thermal resistance junction to ambient air Wärmewiderstand Sperrschicht – umgebende Luft				$R_{thA}$ $< 70\text{ K/W}^1$
Thermal resistance junction to terminal Wärmewiderstand Sperrschicht – Anschluss				$R_{thT}$ $< 30\text{ K/W}$

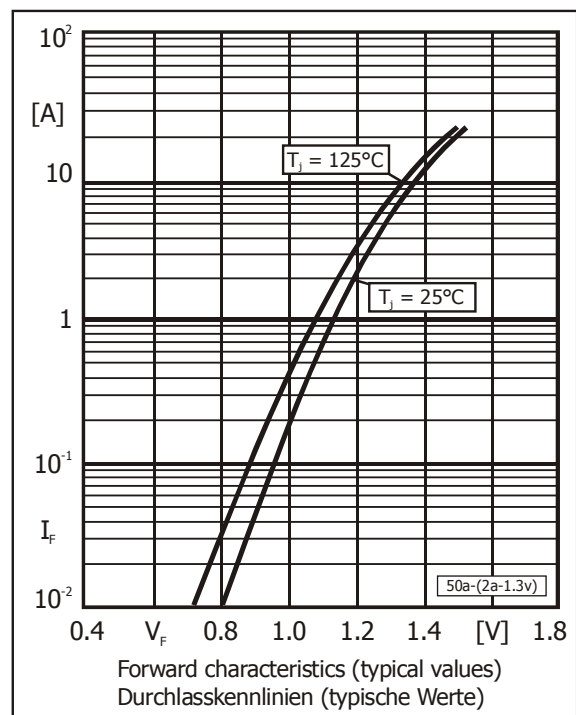
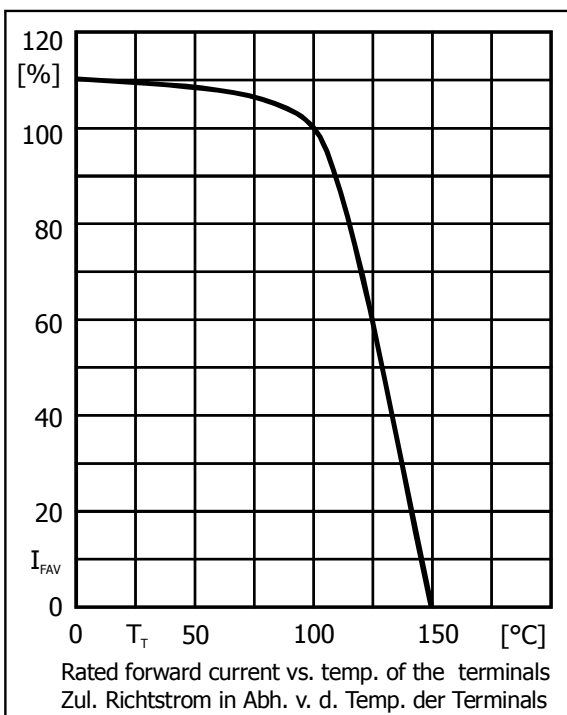

1 Mounted on P.C. board with 25 mm<sup>2</sup> copper pads at each terminal  
Montage auf Leiterplatte mit 25 mm<sup>2</sup> Kupferbelag (Löt-pad) an jedem Anschluss