

SPECIFICATIONS FOR BRIGHT VIEW ELECTRONICS SIDE VIEW LED

MODEL : BSV08WALN

■ Description

The PLCC2 type BSV08WALN SIDE VIEW LED, with its light weight , enables smaller board size, higher packing density, reduced storage space and miniature applications.

- Dice Material : InGaN
- Light Color : White
- Colloid Color : Yellow

**■ Features**

- 1 chip package
- Compatible with automatic placement equipment
- Compatible with reflow soldering process
- Long operating life
- Low forward voltage operated
- Instant light
- Pb -free/ RoHS compliant

■ Applications

- Amusement equipment
- Lighting for small size device
- LCD back light unit
- Information boards
- Key pads
- Light bar
- Decoration
- Marker lights

■ **Outline Dimensions (mm)**

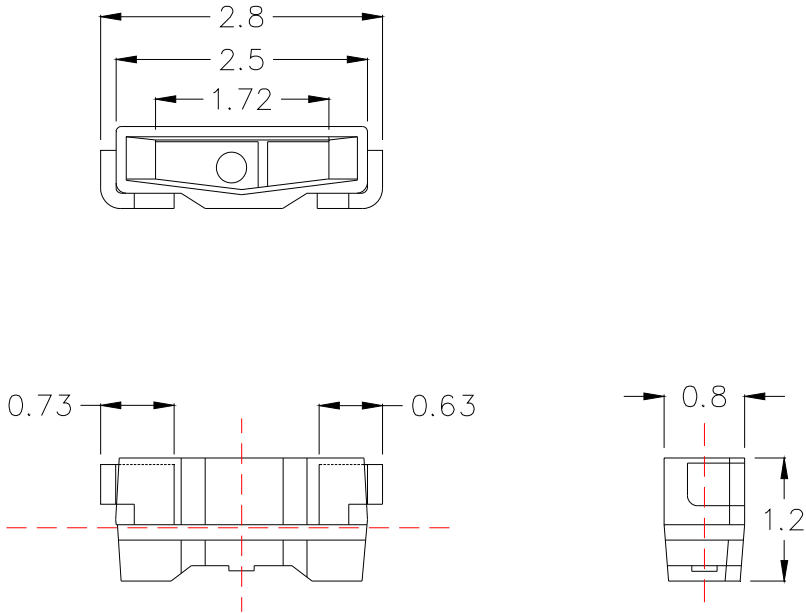

Tolerance : ± 0.1 mm

■ **Recommended Soldering Pad Design**

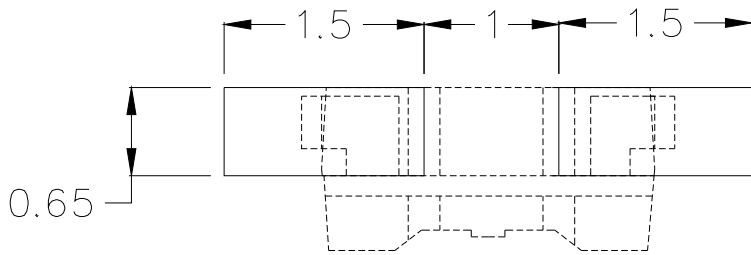

Unit : mm

■ **Part Numbering System**

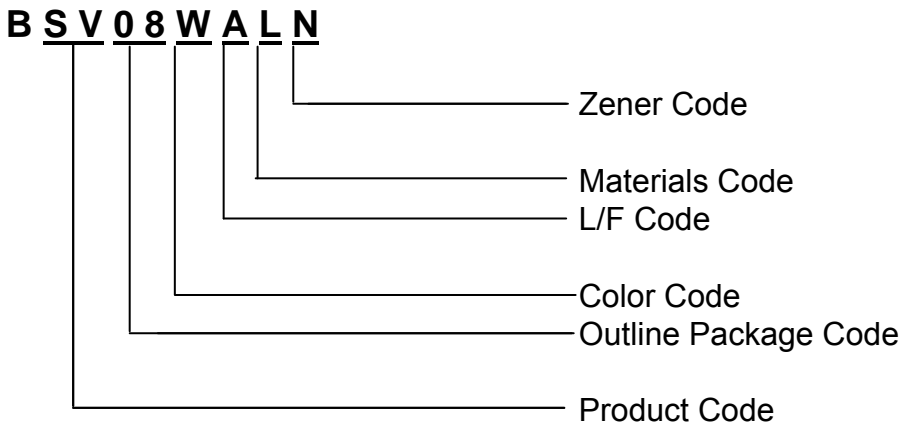

■ **Sub Part Numbering :**

Please also refer to the label on product bags and cartons.

■ Absolute Maximum Ratings at Ta = 25 °C

PARAMETER	symbol	MAX.	UNIT
Power Dissipation	PD	114	mW
Continuous Forward Current	IF	30	mA
Peak Forward Current (1/10 Duty Cycle , 10ms Pulse Width)	IFP	80	mA
Reverse Voltage	VR	5	V
Operating Temperature Range	Topr	-30 to + 85	°C
Storage Temperature Range	Tstg	-40 to + 100	°C
LED Junction Temperature	Tj	100	°C
Reflow Soldering Condition 260 °C for 10 seconds	Tsld	2	times

■ Electro-Optical Characteristics

 Condition : $I_F = 20\text{mA}$, $T_a = 25^\circ\text{C}$

PARAMETER	SYMBOL	TEST CONDITION	VALUES			UNIT
			MIN.	TYP.	MAX.	
Forward Voltage	V_F	$I_F=20\text{mA}$		3.2	3.8	V
Reverse Current	I_R	$V_R= 5\text{V}$			10	μA
Viewing Angle at 50% Iv	2θ 1/2	$I_F=20\text{mA}$		105		Deg.

■ Bin Grade Limits (I_F = 20 mA*) Luminous Intensity / mcd

Item		Min	Max	Unit
Luminous Intensity ¹	Rank B00	1000	1050	mcd
	Rank B05	1050	1100	mcd
	Rank B10	1100	1150	mcd
	Rank B15	1150	1200	mcd
	Rank B20	1200	1250	mcd
	Rank B25	1250	1300	mcd
	Rank B30	1300	1350	mcd
	Rank B35	1350	1400	mcd
	Rank B40	1400	1450	mcd
	Rank B45	1450	1500	mcd
	Rank B50	1500	1550	mcd
	Rank B55	1550	1600	mcd
	Rank B60	1600	1650	mcd
	Rank B65	1650	1700	mcd
	Rank B70	1700	1750	mcd
Rank B75	1750	1800	mcd	

1. Luminous Intensity measurement allowance is 10%.

■ Bin Grade Limits (I_F = 20 mA*) Chromaticity Coordinates

Bin	Color Ranks					Bin	Color Ranks				
A1	x	0.2630	0.2600	0.2690	0.2720	C3	x	0.2910	0.2880	0.2960	0.2980
	y	0.2435	0.2475	0.2610	0.2580		y	0.2580	0.2620	0.2760	0.2710
A2	x	0.2720	0.2630	0.2720	0.2800	D1	x	0.2910	0.2887	0.2968	0.2990
	y	0.2340	0.2435	0.2580	0.2480		y	0.2870	0.2916	0.3058	0.3010
A3	x	0.2755	0.2720	0.2800	0.2830	D2	x	0.2960	0.2910	0.2990	0.3040
	y	0.2310	0.2340	0.2480	0.2440		y	0.2760	0.2870	0.3010	0.2900
B1	x	0.2690	0.2793	0.2820	0.2720	D3	x	0.2980	0.2960	0.3040	0.3062
	y	0.2610	0.2755	0.2720	0.2580		y	0.2710	0.2760	0.2900	0.2853
B2	x	0.2800	0.2720	0.2820	0.2880	E1	x	0.2990	0.2968	0.3048	0.3070
	y	0.2480	0.2580	0.2720	0.2620		y	0.3010	0.3058	0.3198	0.3150
B3	x	0.2830	0.2800	0.2880	0.2910	E2	x	0.3040	0.2990	0.3070	0.3120
	y	0.2440	0.2480	0.2620	0.2580		y	0.2900	0.3010	0.3150	0.3040
C1	x	0.2820	0.2793	0.2887	0.2910	E3	x	0.3062	0.3040	0.3120	0.3142
	y	0.2720	0.2755	0.2916	0.2870		y	0.2853	0.2900	0.3040	0.2993
C2	x	0.2880	0.2820	0.2910	0.2960						
	y	0.2620	0.2720	0.2870	0.2760						

*.Color Coordinates Measurement allowance is ± 0.01

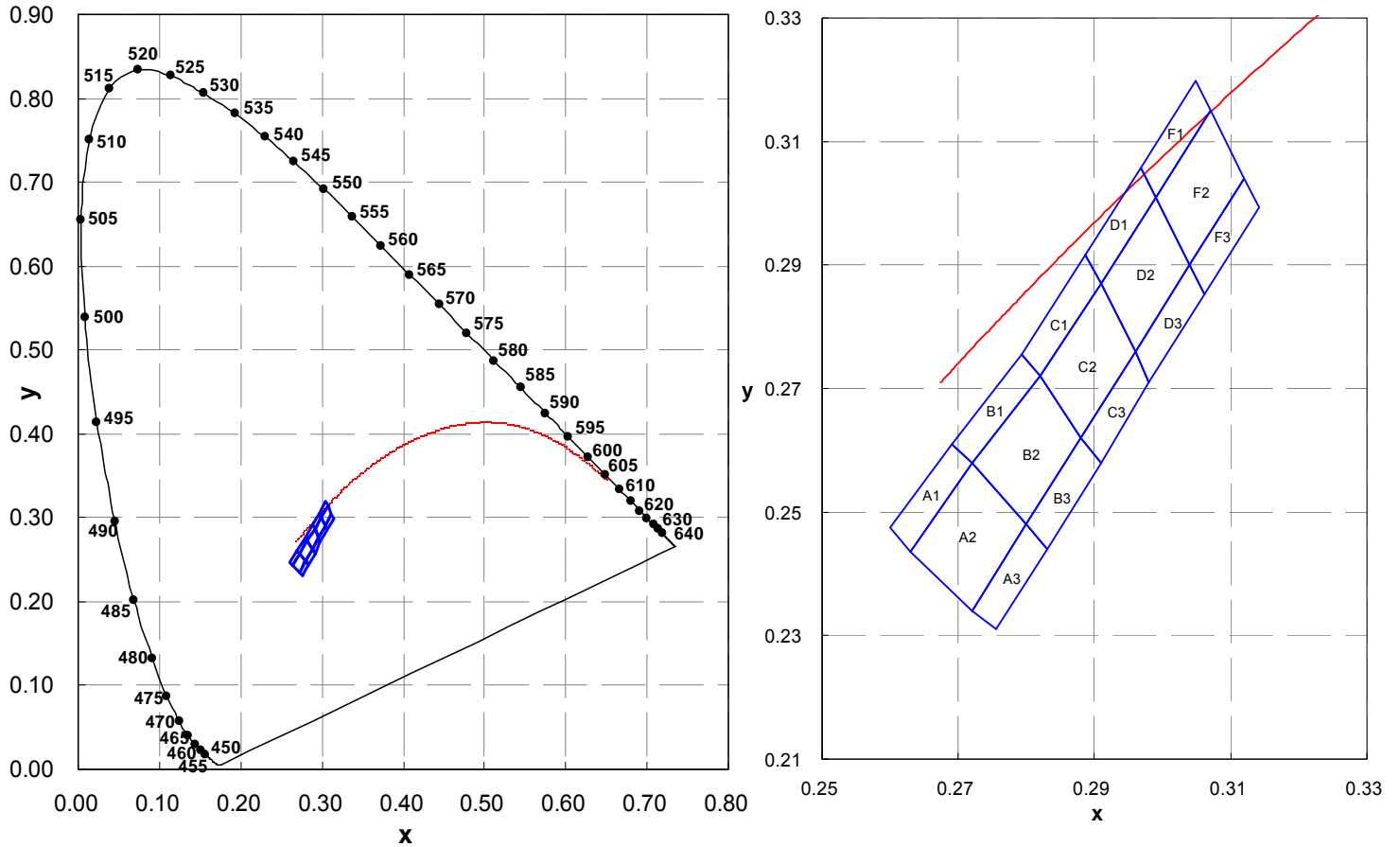
Chromaticity Diagram CIE 1931

Bin Grade Limits (I_F = 20 mA*) Forward Voltage

Please contact our sales department for more information.

Characteristics Data

TYPICAL ELECTRICAL / OPTICAL CHARACTERISTIC CURVES

FIG. 1 Forward Current vs. Forward Voltage

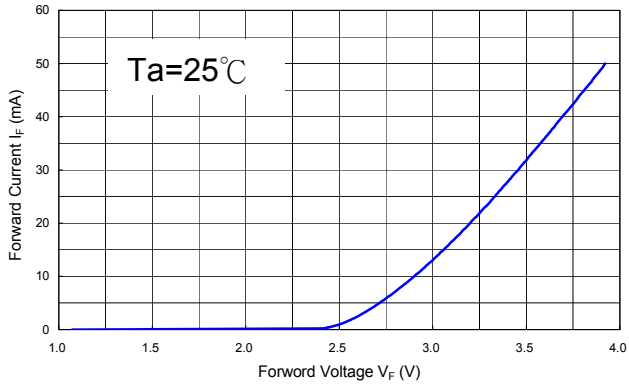

Fig. 2 Relative Intensity vs. Forward Current

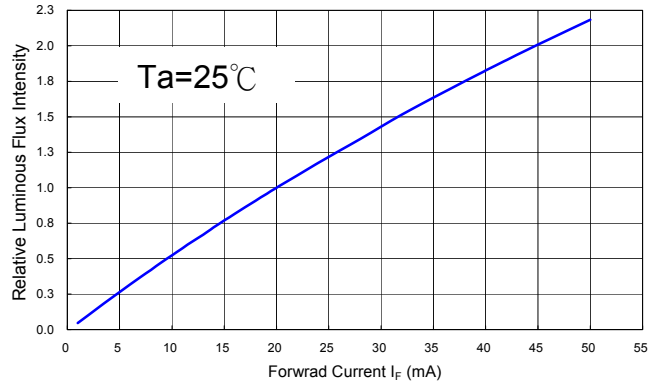

Fig. 3 Relative Voltage vs. Temperature

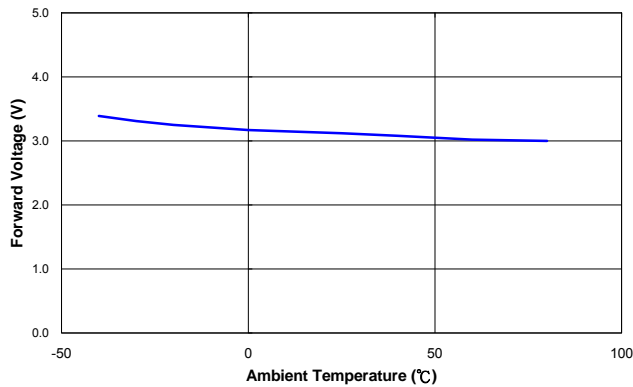

Fig. 4 Relative Intensity vs. Temperature

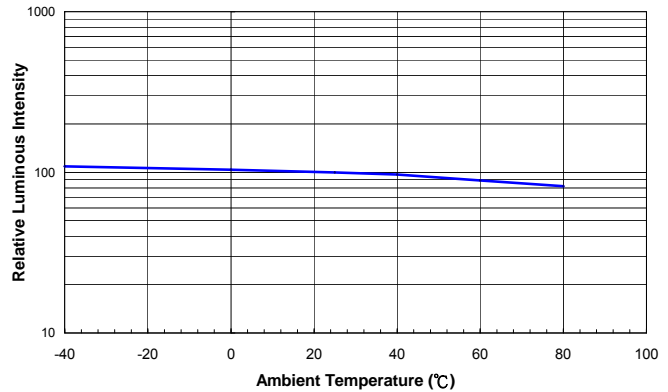

Fig. 5 Relative Intensity vs. Wavelength (λ_p)

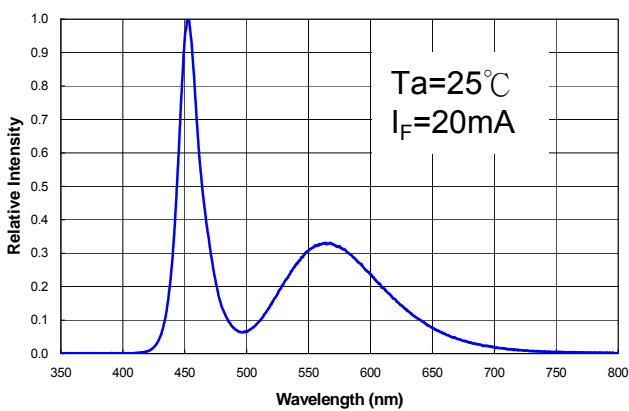
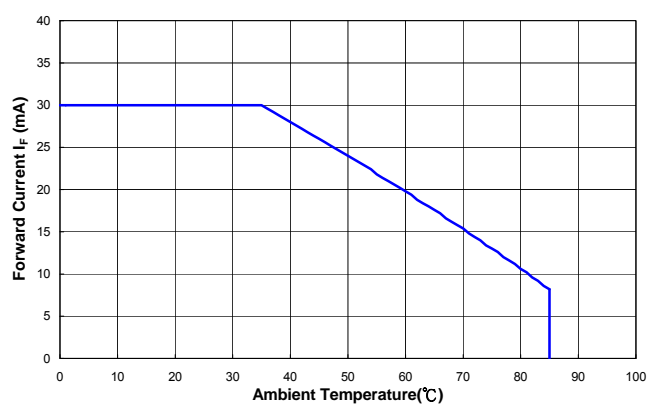
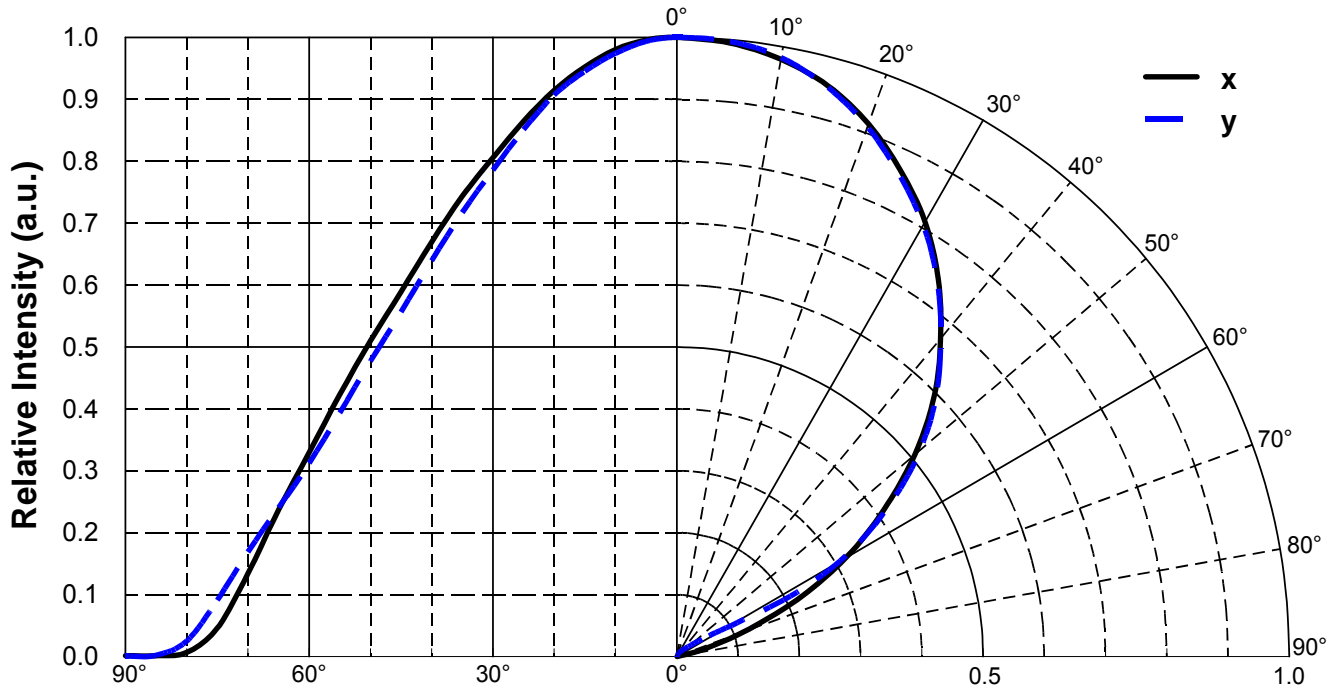

Fig. 6 Derating Curve



■ **Radiation Characteristic**



■ Packaging

■ Package Carrier Tape Dimensions (mm)

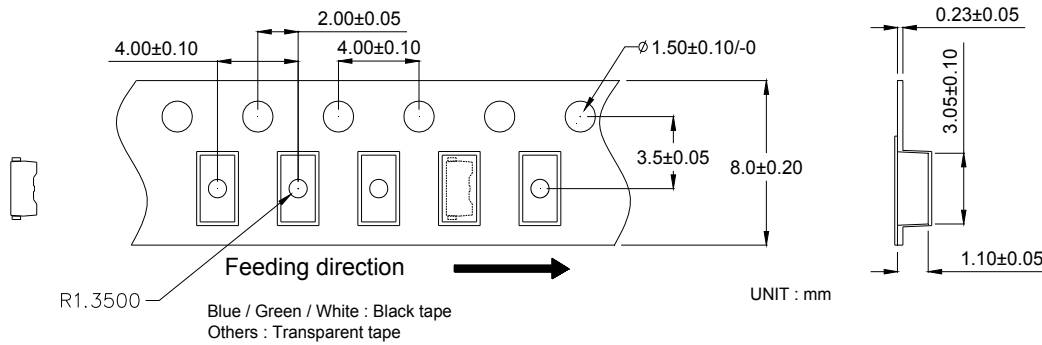

■ Package Reel Dimensions

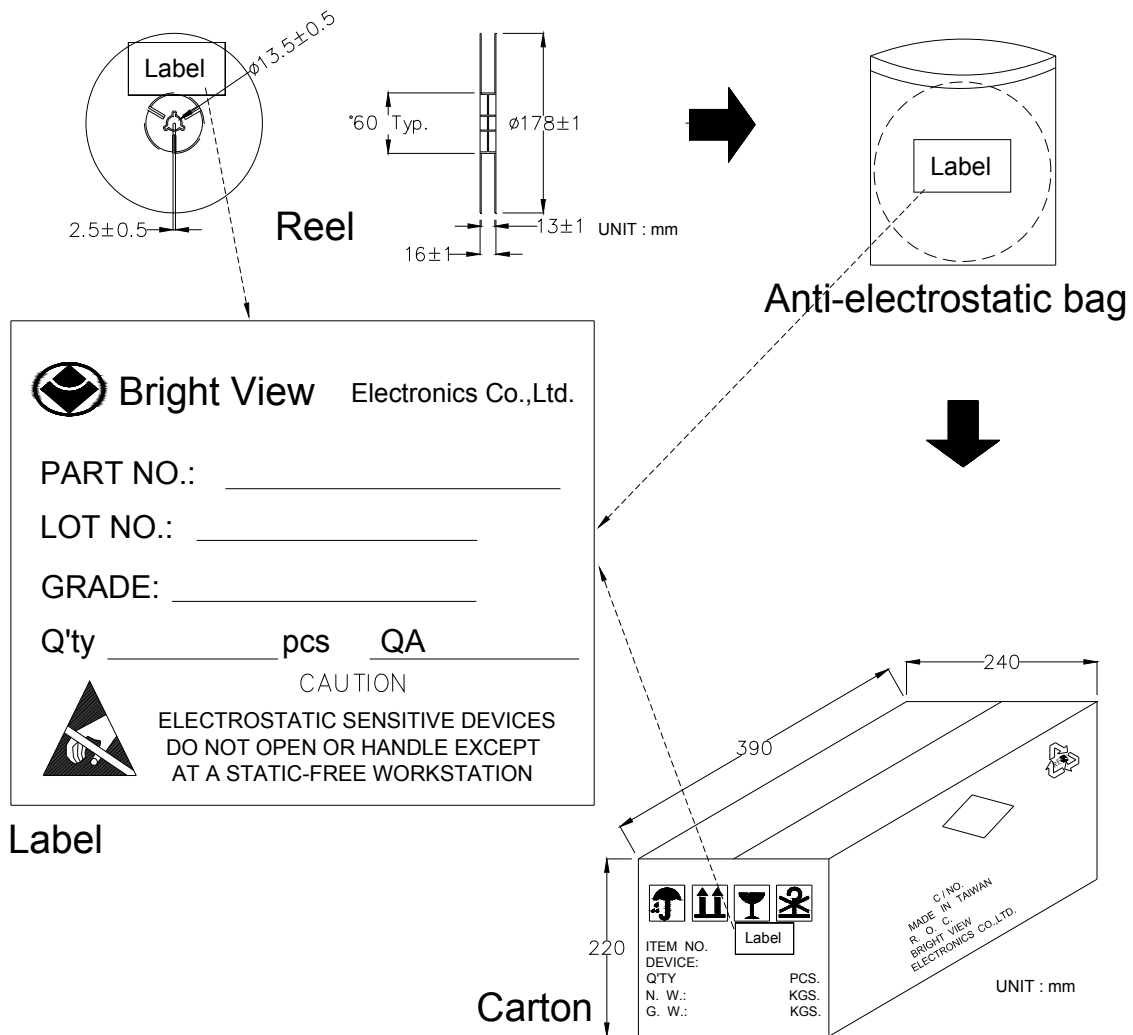

■ Reliability Test Items and Conditions
(1)TEST ITEMS AND RESULTS

Test Item	Standard Test Method	Test Conditions	Note	Number of Damaged
Resistance to Soldering Heat (Reflow Soldering)	JEITA ED-4701 300 301	Tsd=260°C , 10secs (Pre treatment 30°C , 70%, 168hrs)	2 times	0/22
Thermal Shock	JEITA ED-4701 300 307	0°C ~ 100°C 5min. 5min.	100 cycles	0/22
Temperature Cycle	JEITA ED-4701 100 105	-40°C ~ 25°C ~ 100°C ~ 25°C 30min. 5min. 30min. 5min.	100 cycles	0/22
High Temperature Storage	JEITA ED-4701 200 201	Ta=100°C	1000 hrs.	0/22
Low Temperature Storage	JEITA ED-4701 200 202	Ta=-40°C	1000 hrs.	0/22
Steady State Operating Life Condition 1	—	Ta=25°C, I _F =20mA, DC	1000 hrs.	0/22
Steady State Operating Life Condition 2	—	Ta=25°C, I _F =30mA, DC	500 hrs.	0/22
Steady State Operating Life of High Temperature	—	Ta=85°C, I _F =8.5mA, DC	1000 hrs.	0/22
Steady State Operating Life of High Humidity Heat	—	60°C, RH=90%, I _F =20mA, DC	500 hrs.	0/22

(2)CRITERIA FOR JUDGING DAMAGE

Item	Symbol	Test Conditions	Criteria for Judgement	
			Min	Max
Forward Voltage	V _F	I _F =20mA	—	U.S.L.*) x 1.2
Reverse Current	I _R	V _R =5V	—	10μA
Luminous Intensity	I _V	I _F =20mA	L.S.L.**) x 0.7	—

*)U.S.L.:Upper Standard Level

**)L.S.L.:Lower Standard Level

■ Cautions**(1) Moisture Proof Package**

- * The moisture proof package, a plastic bag with a zipper, is used to keep moisture to a minimum in the package.
- * A package of a moisture absorbent material (silica gel) is also inserted into the plastic moisture proof bag and the silica gel changes its color from blue to pink as it absorbs moisture.
- * The absorbed moisture in the SMT package may vaporize and expand during soldering. This may cause exfoliation of the contacts and damage to the optical characteristics of the LEDs.

(2) Storage Conditions

- * Before opening the package :
The LEDs should be kept at 30°C or less and 45~60% RH or less and should be used within a year. When storing the LEDs, moisture proof package with absorbent material (silica gel) is recommended.
- * After opening the package :
The LEDs should be kept at 30°C or less and 55% RH or less and should be soldered within 168 hours (7days) after opening the package. The unused LEDs should be stored in moisture proof packages.
- * It's also recommended to return the LEDs to the original moisture proof bag and to reseal the moisture proof bag again.
- * If the moisture absorbent material (silica gel) has faded away or the SMD LEDs have exceeded the storage time, baking treatment (more than 24 hours at 65+/-5°C) should be performed before soldering.

(3) Heat Generation

- * The thermal design of the end product is very important. It is necessary to avoid intense heat generation and operate within the maximum ratings given in this specification.
- * The operating current should be decided after considering the ambient maximum temperature of LEDs.

(4) Cleaning

- * Isopropyl alcohol is recommended to be used as a solvent for cleaning the LEDs.
- * Before cleaning, a pre-test should be done to confirm whether any damage to the LEDs will occur.

(5) Soldering

Reflow Soldering (recommended) :

- * To prevent from cracking, please bake (65°C , 24hrs) before soldering.
- * When soldering, do not load stress on the LEDs during heating.
- * Never take next process until the component is cooled down to room temperature after reflow.
- * After soldering, do not warp the circuit board.
- * The recommended reflow soldering profile (measuring on the surface of the LED resin) is the following:

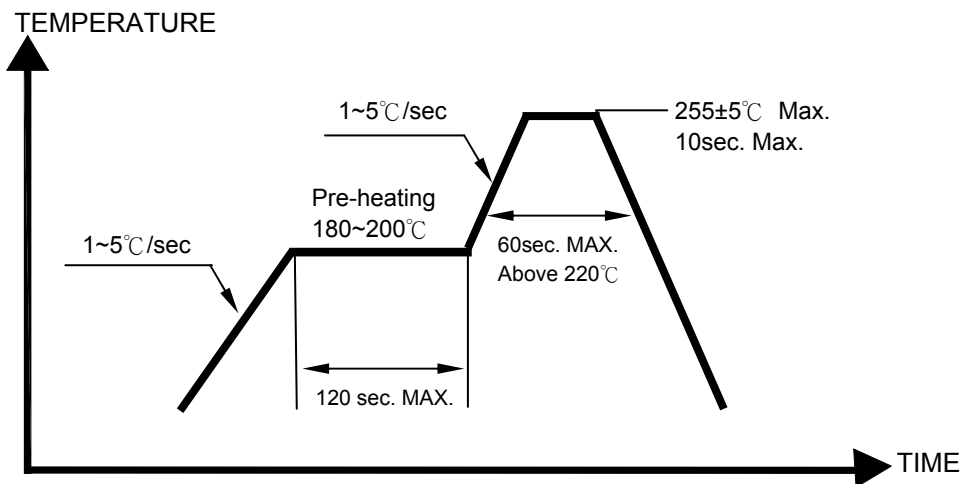
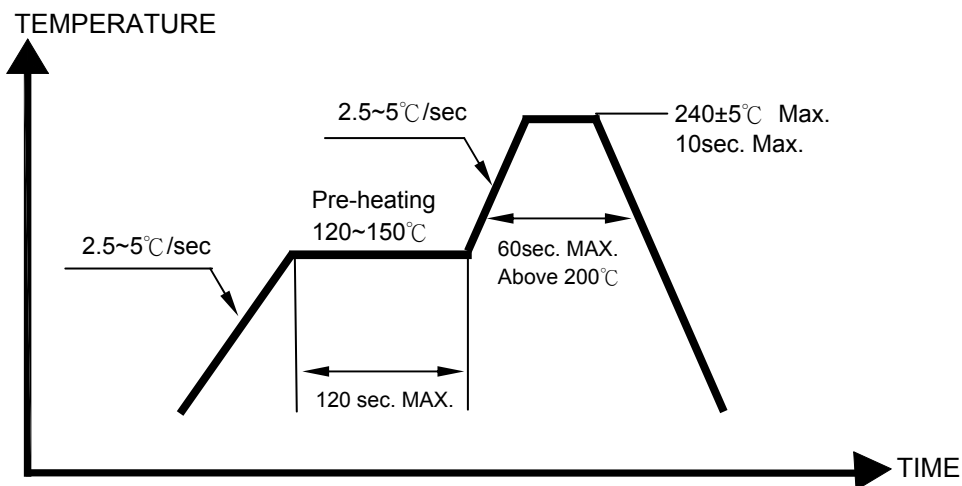
(a) Lead-Free Solder

(b) Lead Solder

Manual Soldering (not recommended) :

- * To prevent from cracking, please bake (65°C , 24hrs) before soldering.
- * Temperature at tip of iron: 250°C Max. (25W).
- * It's banned to load any stress on the resin during soldering.
- * Soldering time: 3 sec. Max. (for one time only)

(6) ESD (electrostatic discharge) protection (base on machine mode)

- * The product is Gallium Nitride (GaN) based light emitting diode (LED) and is extremely sensitive to ESD. Users are strongly recommended to take necessary meter to test the static electricity and avoid ESD when handling this product.
- * Proper grounding of machines (via $1M\Omega$), using static dissipative mats, containers, working uniforms and shoes are considered to be effective against ESD.
- * An ionizer is recommended in the facility or environment where ESD may be generated easily, and soldering iron with a grounded tip is also recommended.
- * When inspecting the final products in which LEDs are assembled, it is recommended to check whether the assembled LEDs are damaged by ESD or not. It is simple to find damaged LEDs by light-on or VF test at lower current (below 1mA is recommended).
- * ESD damaged LEDs will show some unusual characteristics such as the remarkable increasing of leak current, the decreasing of forward voltage, or the LEDs do not light on at the low current.

(7) Other

- * Care must be taken to ensure that the reverse voltage will not exceed the absolute maximum rating when using the LEDs with matrix drive.
- * The LED light output is strong enough to injure human eyes. Precaution must be taken to prevent looking directly at the LEDs with unaided eyes for more than a few seconds.
- * The LEDs described here are intended to be used for ordinary electronic equipment, please consult Bright View's sales department in advance for information on applications.
- * Installing a protection device in the LED driving circuit to avoid surge current exceeding the max rating during on/off switching.
- * The appearance and specifications of the product may be modified for improvement without notice.
- * Please use the product within 168 hours after opening the seal and keep under $30\text{ }^{\circ}\text{C}$ and 70% humidity.
- * Bright View will not be responsible for any claim for damage if the user use the product without following the caution or instruction of the specification.