

Nominal breakdown voltage V_N	350	V
Initial values ²⁾		
Static breakdown voltage V_S ¹⁾		
First ignition value $V_{S, FTE}$ after 24 hours in darkness	≤ 470	V
Following ignition values $V_{S, FIV}$	298 ... 402	V
Electrical life time ³⁾		
Breakdown voltage V_B		
First ignition value $V_{B, FTE}$ after 24 hours in darkness	≤ 500	V
Following ignition values $V_{B, FIV}$	280 ... 420	V
Switching operations at -40 ... +125 °C	400 000	Ignitions
Test circuit parameters		
Open circuit voltage V_0	500	V
Loading resistance R	20	k Ω
Discharge capacitance C	330	nF
Inductance L	0.4	μ H
Discharge peak current I_P	~ 300	A
General technical data		
Insulation resistance at 100 V	> 100	M Ω
Early ignition values 200 ... 280 V	≤ 4	%
Breakdown time	≤ 50	ns
Maximum switching frequency	100	Hz
Weight	~ 2	g
Marking, red	EPCOS 350 YY O 350 - Nominal voltage YY - Year of production O - Non radioactive	

¹⁾ At delivery AQL 0,65 level II, DIN ISO 2859

²⁾ Page 2, Fig. 1 and 2

³⁾ Page 2, Fig. 3 and 4

Fig. 1: QC- test circuit (100% outgoing inspection)

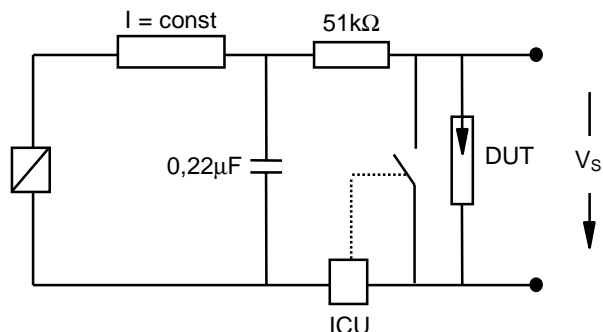

DUT device under test
 ICU ignition control unit (sensitivity 10 .. 30 μA)
 Discharge current 10 – 20 mA

Fig. 2: Explanation of measurands

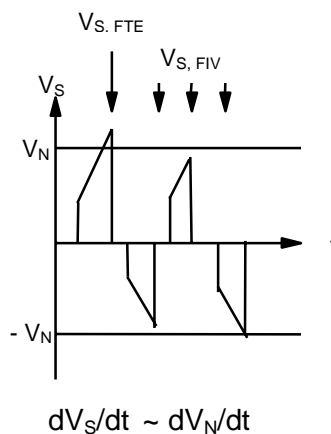

Fig. 3: QC- test circuit (sampling inspection at 25 °C)

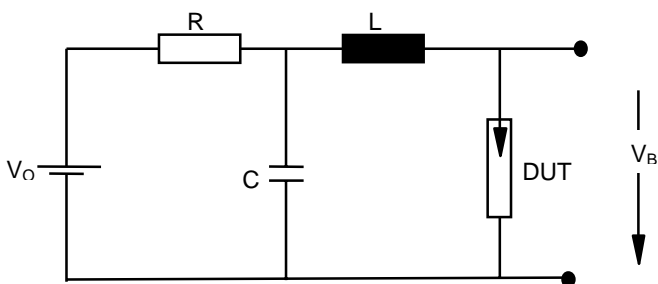
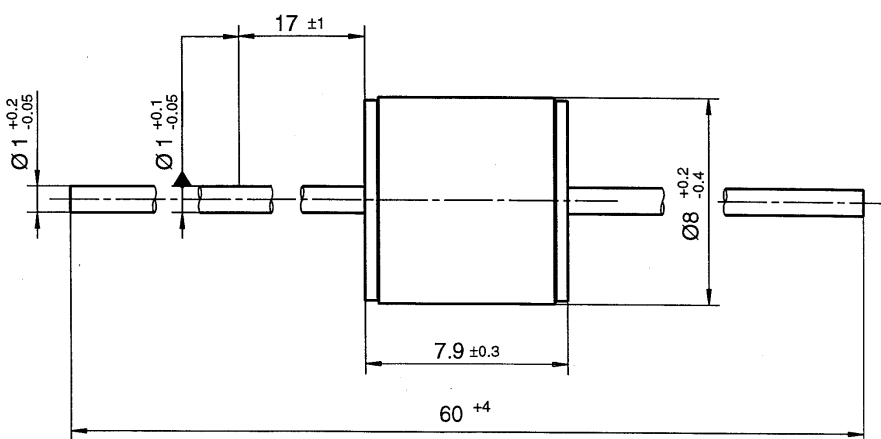
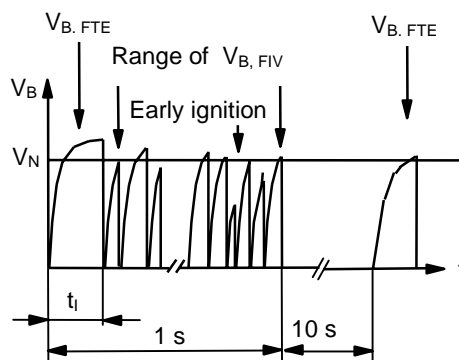

Fig. 4: Explanation of measurands



Not to scale
 Dimensions in mm
 Non controlled document

© EPCOS AG 2002. Reproduction, publication and dissemination of this data sheet, enclosures hereto and the information contained therein without EPCOS' prior express consent is prohibited.

Purchase orders are subject to the General Conditions for the Supply of Products and Services of the Electrical and Electronics Industry recommended by the ZVEI (German Electrical and Electronic Manufacturers' Association), unless otherwise agreed.