

MULTI-RATE OC-48/STM-16 LR-2/L-16.2 SFP DWDM TRANSCEIVERS WITH DIGITAL DIAGNOSTICS

TRPW48L2/E2 DWDM

Product Description

The TRPW48L2/E2 DWDM SFP series of multi-rate fiber optic transceivers with digital diagnostics monitoring functionality provide a quick and reliable interface for long reach applications. Diagnostics monitoring functionality (alarm and warning features) is integrated into the design via an I2C serial interface per the Multi-Source Agreement (MSA) on DWDM SFP transceivers (Rev. 1.0, October 2005).

Products under this series are compatible with SONET/SDH standards for OC-48/STM-16 (2.67Gb/s) Forward Error Correction and OC-48/STM-16 (2.488Gb/s) LR-2/L-16.2 long reach applications, OC-3/STM-1 (156Mb/s) and OC-12/STM-4 (622Mb/s) SR/I-1 and I-4 short reach applications; Gigabit Ethernet LX (1.25Gb/s) applications per IEEE 802.3; and Fibre Channel 200-SM-LC-L (2.125Gb/s) and 100-SMLC-L (1.062Gb/s) applications per FC-PI standards. The transmitter incorporates a highly reliable 1550nm DFB laser with an operating wavelength in full compliance with 100GHz (0.8nm) spacing per ITU-grid. All transceivers are Class I Laser products per U.S. FDA/CDRH and international IEC-60825 standards.

The TRPW48L2/E2 DWDM transceivers connect to standard 20-pad SFP connectors for hot plug capability. This allows

the system designer to make configuration changes or maintenance by simply plugging in different types of transceivers without removing the power supply from the host system.

The transceivers have blue bail-type latches, which offer an easy and convenient way to release the modules. The latch is compliant with the SFP MSA.

The transmitter and receiver DATA interfaces are AC-coupled internally. LV-TTL Transmitter Disable control input and Loss of Signal (LOS) output interfaces are also provided. The transceivers operate from a single +3.3V power supply over an operating case temperature range of -5°C to +70°C (Commercial) or -5°C to +85°C (Extended). The housing is made of metal designed for optimum thermal performance and electromagnetic compatibility.

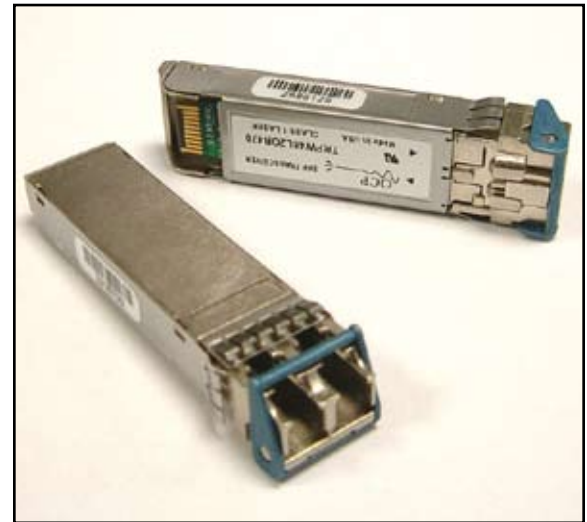

Features

- ☑ Compliant with DWDM SFP MSA
- ☑ Multi-rate Operations from 125Mb/s to 2.67Gb/s
- ☑ Support 2.67Gb/s OC-48 FEC Rate
- ☑ 1550nm DFB Laser Transmitter & APD Receiver
- ☑ Long Haul Transmission Distance of 80km or 120km
- ☑ Compliant with G.692
- ☑ 100GHz Channel Spacing
- ☑ Optical Link Power Budget of 28dB Minimum
- ☑ Digital Diagnostics through Serial Interface
- ☑ Internal Calibration for Digital Diagnostics
- ☑ Eye Safe (Class I Laser Safety)
- ☑ Hot-pluggable
- ☑ TX Fault & Loss of Signal Outputs
- ☑ TX Disable Input
- ☑ Temperature option of -5°C to +85°C

Absolute Maximum Ratings

Parameter	Symbol	Minimum	Maximum	Units
Storage Temperature	T_{ST}	- 40	+ 85	°C
Operating Case Temperature ¹	Commercial	- 5	+ 70	°C
	Extended	- 5	+ 85	
Supply Voltage	V_{CC}	0	+ 4.5	V
Maximum Input Optical Power (30 seconds max.)	$P_{in, max}$	-	+ 3.0	dBm
Input Voltage	V_{IN}	0	V_{CC}	V

¹ Measured on top side of SFP module at the front center vent hole of the cage.

Transmitter Performance Characteristics (Over Operating Case Temperature. $V_{CC} = 3.13$ to $3.47V$)

All parameters guaranteed only at typical data rate

Parameter ¹		Symbol	Minimum	Typical	Maximum	Units
Operating Data Rate		B	0.125	-	2.67	Gb/s
Average Optical Output Power (coupled into single mode fiber), 50% duty cycle		P_O	0	-	+ 4.0	dBm
Extinction Ratio		P_{hi} / P_{lo}	8.2	-	-	dB
Center Wavelength ²		λ_C	see Ordering Information Table			-
Spectral Width (-20dB) ³		$\Delta\lambda_{20}$	-	-	0.4	nm
Optical Output Power of OFF Transmitter		P_{OFF}	-	-	- 45.0	dBm
Side Mode Suppression Ratio		$SMSR$	30	-	-	dB
Optical Rise/Fall Time (20% to 80%)		t_r, t_f	-	-	0.16	ns
Relative Intensity Noise		RIN	-	-	- 117	dB/Hz
Jitter Generation	OC-48	JG	-	-	0.07	UIp-p
Dispersion Penalty ⁴	1600ps/nm (80km)	-	-	-	2.0	dB
	2400ps/nm (120km)		-	-	2.0	
Optical Output Eye		Compliant with Telcordia GR-253-CORE and ITU-T Recommendation G.957				
¹ Specified through EOL.						
² BOL: +/-0.05nm from ITU grid. EOL: +/-0.1nm from ITU grid.						
³ Measured with OSA and 0.1nm resolution bandwidth.						
⁴ Corresponds to the approximate worst-case dispersion for G.652/G.654 fiber over the center wavelength range of 1528.77-1563.86nm.						

Receiver Performance Characteristics (Over Operating Case Temperature. $V_{CC} = 3.13$ to $3.47V$)

All parameters guaranteed only at typical data rate

Parameter ¹		Symbol	Minimum	Typical	Maximum	Units
Operating Data Rate		B	0.125	-	2.67	Gb/s
Receiver Sensitivity (10^{-10} BER) ²	OC-3/12/48, 2.67Gb/s	P_{min}	- 28.0	-	-	dBm
Receiver Sensitivity (10^{-12} BER) ³	2.125Gb/s, 1.25Gb/s, 1.062Gb/s, 0.125Gb/s	P_{min}	- 28.0	-	-	dBm
Maximum Input Optical Power (10^{-12} BER)		P_{max}	- 8.0	-	-	dBm
LOS Thresholds	Increasing Light Input	P_{los+}	-	-	- 28.0	dBm
	Decreasing Light Input	P_{los-}	- 45.0	-	-	
LOS Timing Delay	Increasing Light Input	$t_{loss\ off}$	-	-	100	μs
	Decreasing Light Input	$t_{loss\ on}$	2.3	-	100	
LOS Hysteresis		-	0.5	1.5	-	dB
Wavelength of Operation		λ	1260	-	1570	nm
Receiver Reflectance		-	-	-	-27.0	dB
¹ Specified through EOL.						
² Measured with 2^{23} -1 PRBS.						
³ Measured with 2^7 -1 PRBS.						

Laser Safety: All transceivers are Class I Laser products per FDA/CDRH and IEC-60825 standards. They must be operated under specified operating conditions.

Oplink Communications, Inc.	
DATE OF MANUFACTURE:	
	
This product complies with 21 CFR 1040.10 and 1040.11 Meets Class I Laser Safety Requirements	

Transmitter Performance Characteristics (Over Operating Case Temperature. $V_{CC} = 3.13$ to $3.47V$)

Parameter	Symbol	Minimum	Typical	Maximum	Units
Input Voltage Swing (TD+ & TD-) ¹	V_{PP-DIF}	0.35	-	1.75	V
Input HIGH Voltage (TX Disable) ²	V_{IH}	2.0	-	V_{CC}	V
Input LOW Voltage (TX Disable) ²	V_{IL}	0	-	0.8	V
Output HIGH Voltage (TX Fault) ³	V_{OH}	2.0	-	$V_{CC} + 0.3$	V
Output LOW Voltage (TX Fault) ³	V_{OL}	0	-	0.8	V

¹ Differential peak-to-peak voltage.
² There is an internal 4.7 to 10kΩ pull-up resistor to V_{CC} .
³ Open collector compatible, 4.7 to 10kΩ pull-up resistor to V_{CC} (Host Supply Voltage).

Receiver Electrical Interface (Over Operating Case Temperature. $V_{CC} = 3.13$ to $3.47V$)

Parameter	Symbol	Minimum	Typical	Maximum	Units
Output Voltage Swing (RD+ & RD-) ¹	V_{PP-DIF}	0.40	-	1.75	V
Output HIGH Voltage (LOS) ²	V_{OH}	$V_{CC} - 1.3$	-	$V_{CC} + 0.3$	V
Output LOW Voltage (LOS) ²	V_{OL}	0	-	0.5	V

¹ Differential peak-to-peak voltage across external 100Ω load.
² Open collector compatible, 4.7 to 10kΩ pull-up resistor to V_{CC} (Host Supply Voltage).

Electrical Power Supply Characteristics (Over Operating Case Temperature. $V_{CC} = 3.13$ to $3.47V$)

Parameter	Symbol	Minimum	Typical	Maximum	Units
Supply Voltage	V_{CC}	3.13	3.3	3.47	V
Supply Current	I_{CC}	-	-	345	mA

Module Definition

MOD_DEF(0) pin 6	MOD_DEF(1) pin 5	MOD_DEF(2) pin 4	Interpretation by Host
TTL LOW	SCL	SDA	Serial module definition protocol

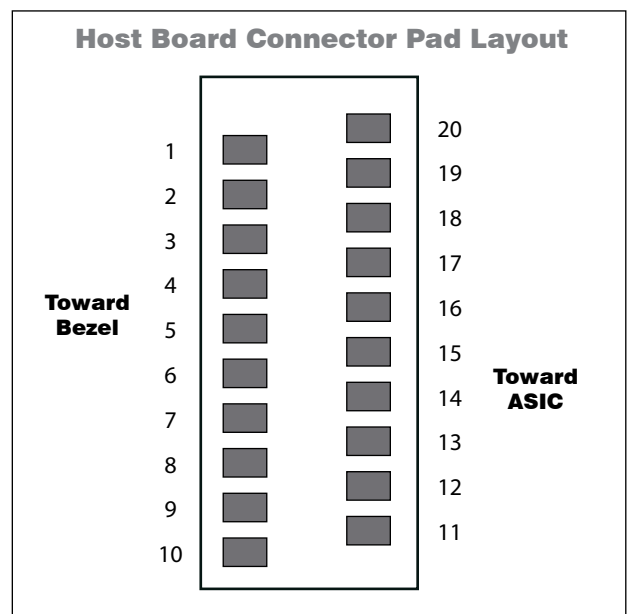
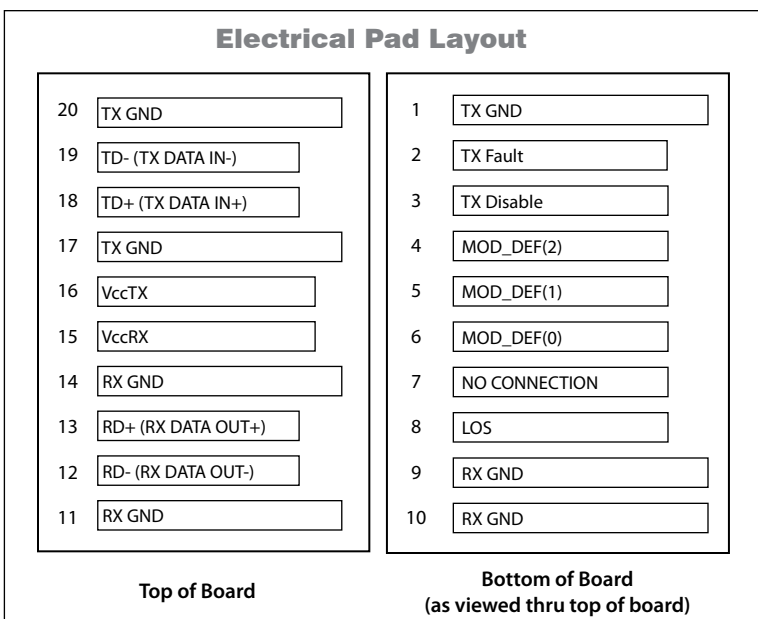

Example of SFP host board schematic

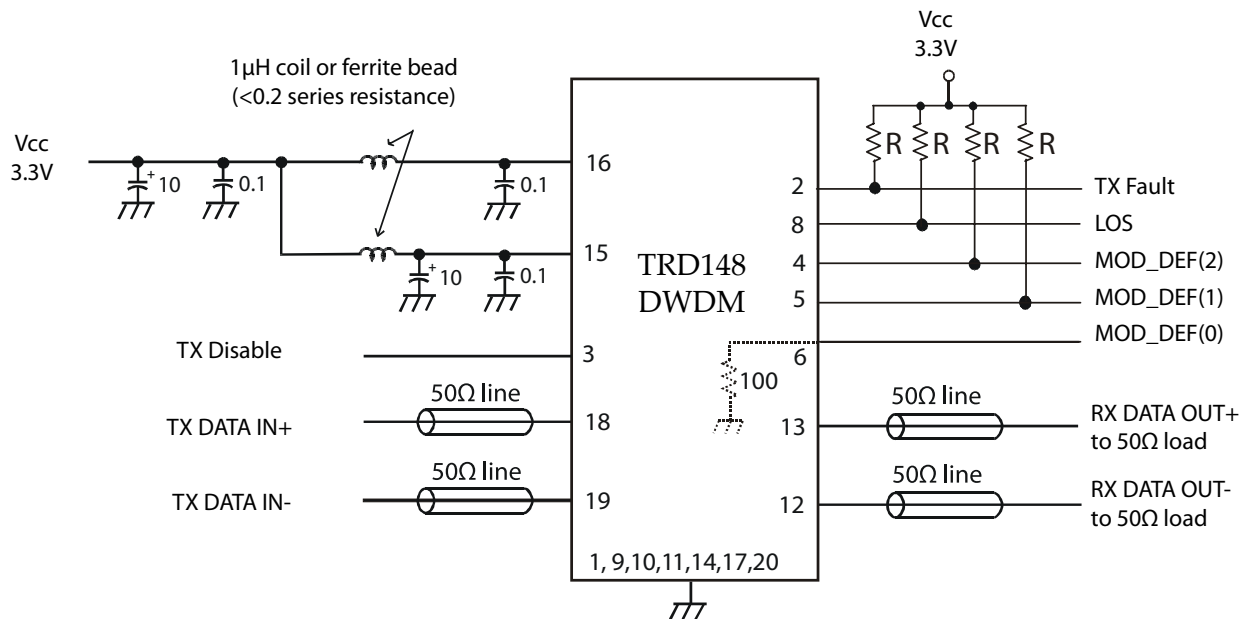

R: 4.7 to 10kΩ

Application Notes

Electrical interface: All signal interfaces are compliant with the SFP MSA specification. The high speed DATA interface is differential AC-coupled internally with 0.1µF and can be directly connected to a 3.3V SERDES IC. All low speed control and sense output signals are open collector TTL compatible and should be pulled up with a 4.7 - 10kΩ resistor on the host board

Loss of Signal (LOS): The Loss of Signal circuit monitors the level of the incoming optical signal and generates a logic HIGH when an insufficient photocurrent is produced.

TX Start-up: During power up or hot plugging the DWDM SFP module will initially set the TX to the correct operating temperature. Depending on the ambient temperature this may take several seconds to 1 minute. When the Tx has reached the required temperature the Tx is switched on and active. At this point the Tx is guaranteed to be within +/-0.2nm of the appropriate ITU wavelength and will settle to +/-0.05nm within the time limit set by the MSA.

TX_Fault: The output indicates LOW when the transmitter is operating normally, and HIGH with a laser fault including laser end-of-life. TX Fault is an open collector/drain output that should be pulled up with a 4.7 - 10kΩ resistor on the host board. TX Fault is latched per SFP MSA.

TX_Disable: When the TX Disable pin is at logic HIGH, the transmitter optical output is disabled (less than -45dBm).

Serial Identification and Monitoring: The module definition of SFP is indicated by the three module definition pins, MOD_DEF(0), MOD_DEF(1) and MOD_DEF(2). Upon power up, MOD_DEF(1:2) appear as NC (noconnection), and MOD_DEF(0) is TTL LOW. When the host system detects this condition, it activates the serial protocol (standard two-wire I²C serial interface) and generates the serial clock signal (SCL). The positive edge clocks data into the EEPROM segments of the SFP that are not write protected, and the negative edge clocks data from the SFP.

The serial data signal (SDA) is for serial data transfer. The host uses SDA in conjunction with SCL to mark the start and end of serial protocol activation. The supported monitoring functions are internal temperature, supply voltage, bias current, transmitter power, average receiver signal, all alarms and warnings and software monitoring of TX Fault/LOS. The device is internally calibrated.

The data transfer protocol and the details of the mandatory and vendor specific data structures are defined in the MSA.

Power supply and grounding: The power supply line should be well-filtered. All 0.1µF power supply bypass capacitors should be as close to the transceiver module as possible.

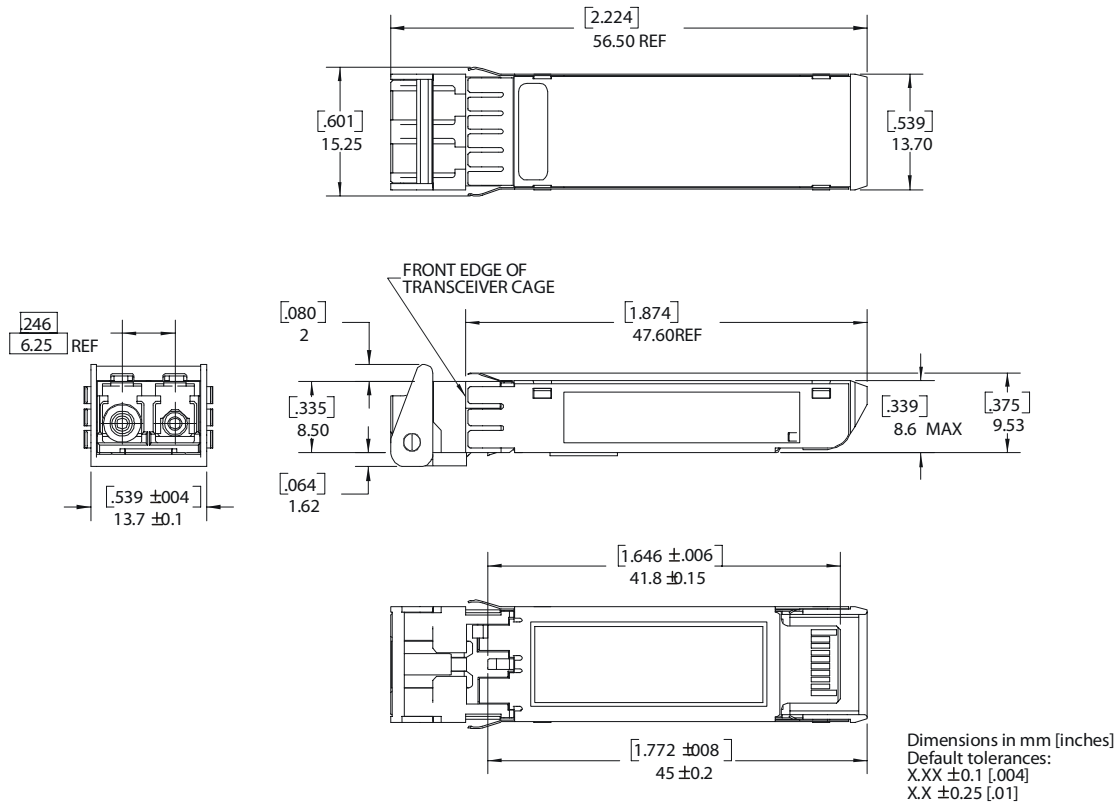
Package Outline

Ordering Information

Oplink can provide a remarkable range of customized optical solutions. For detail, please contact Oplink's Sales and Marketing for your requirements and ordering information (510) 933-7200 or Sales@oplink.com.

46335 Landing Pkwy Fremont, CA 94538 Tel: (510) 933-7200 Fax: (510) 933-7300 Email: Sales@Oplink.com • www.oplink.com