

Silicon NPN Power Transistors

2SC2334

DESCRIPTION

- With TO-220 package
- Complement to type 2SA1010
- Low collector saturation voltage
- Fast switching speed

APPLICATIONS

- Switching regulators
- DC/DC converters
- High frequency power amplifiers

PINNING

PIN	DESCRIPTION
1	Base
2	Collector;connected to mounting base
3	Emitter

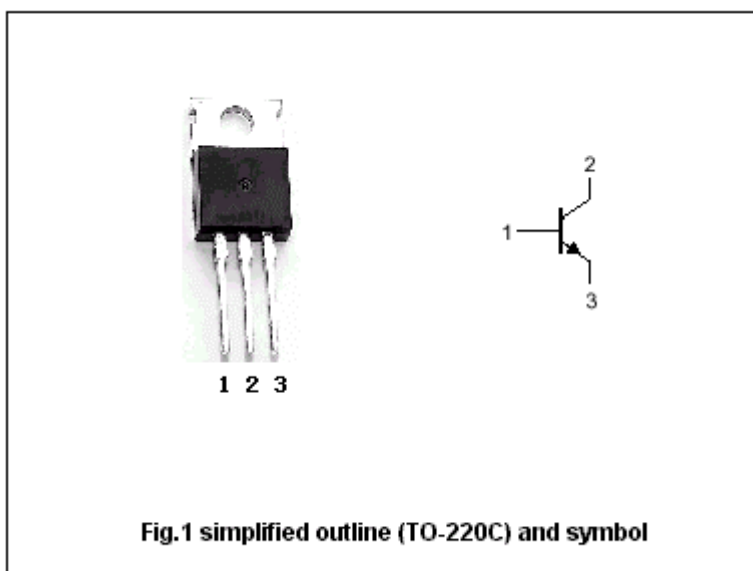

Absolute maximum ratings(Ta=25)

SYMBOL	PARAMETER	CONDITIONS	VALUE	UNIT
V _{CBO}	Collector-base voltage	Open emitter	150	V
V _{CEO}	Collector-emitter voltage	Open base	100	V
V _{EBO}	Emitter-base voltage	Open collector	7	V
I _C	Collector current		7	A
I _{CM}	Collector current-peak		15	A
I _B	Base current		3.5	A
P _T	Total power dissipation	T _a =25	1.5	W
		T _C =25	40	
T _j	Junction temperature		150	
T _{stg}	Storage temperature		-55~150	

Silicon NPN Power Transistors

2SC2334

CHARACTERISTICS

Tj=25 unless otherwise specified

SYMBOL	PARAMETER	CONDITIONS	MIN	TYP.	MAX	UNIT
V _{CEO(SUS)}	Collector-emitter sustaining voltage	I _C =5.0A ,I _B =0.5A,L=1mH	100			V
V _{CEsat}	Collector-emitter saturation voltage	I _C =5A; I _B =0.5A			0.6	V
V _{BEsat}	Base-emitter saturation voltage	I _C =5A; I _B =0.5A			1.5	V
I _{CBO}	Collector cut-off current	V _{CB} =100V; I _E =0			10	μ A
I _{CEX}	Collector cut-off current	V _{CE} =100V; V _{BE(off)} =-1.5V Ta=125			10 1.0	μ A mA
I _{EBO}	Emitter cut-off current	V _{EB} =5V; I _C =0			10	μ A
h _{FE-1}	DC current gain	I _C =0.5A ; V _{CE} =5V	40			
h _{FE-2}	DC current gain	I _C =3A ; V _{CE} =5V	40		200	
h _{FE-3}	DC current gain	I _C =5A ; V _{CE} =5V	20			

Switching times resistive load

t _{on}	Turn-on time	I _C =5.0A I _{B1} =-I _{B2} =0.5A R _L =10 ;V _{CC} 50V			0.5	μ s
t _s	Storage time				1.5	μ s
t _f	Fall time				0.5	μ s

◆ **h_{FE-2} Classifications**

M	L	K
40-80	60-120	100-200

Silicon NPN Power Transistors

2SC2334

PACKAGE OUTLINE

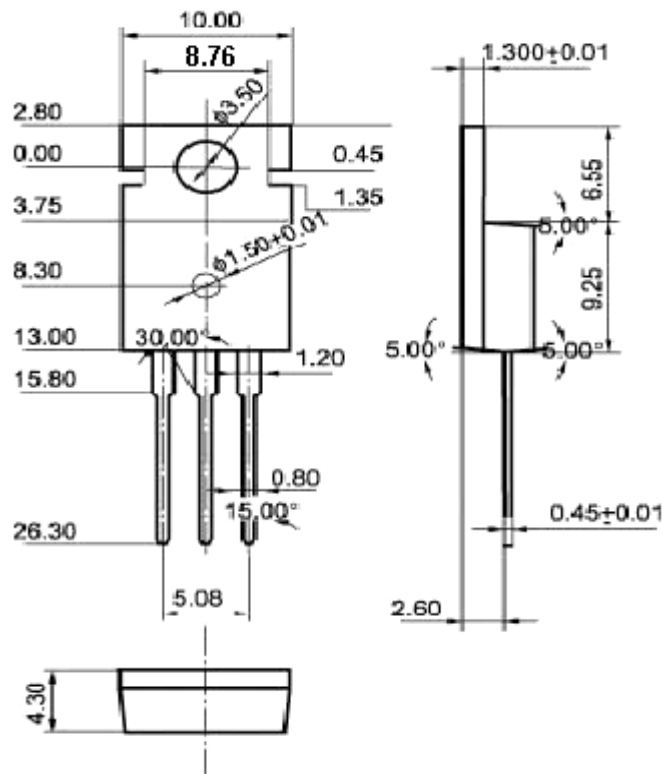

Fig.2 Outline dimensions(unindicated tolerance: ± 0.10 mm)

Silicon NPN Power Transistors

2SC2334

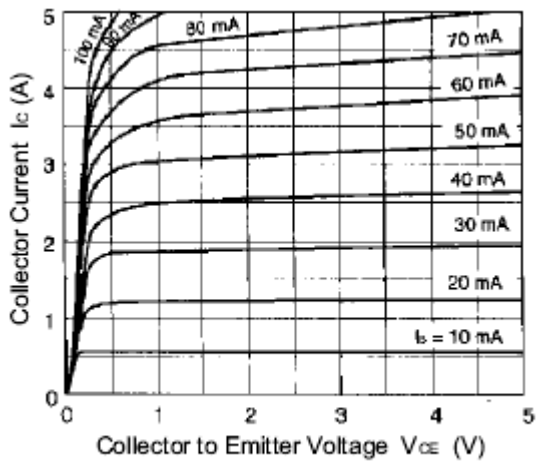

Fig.3 Static Characteristic

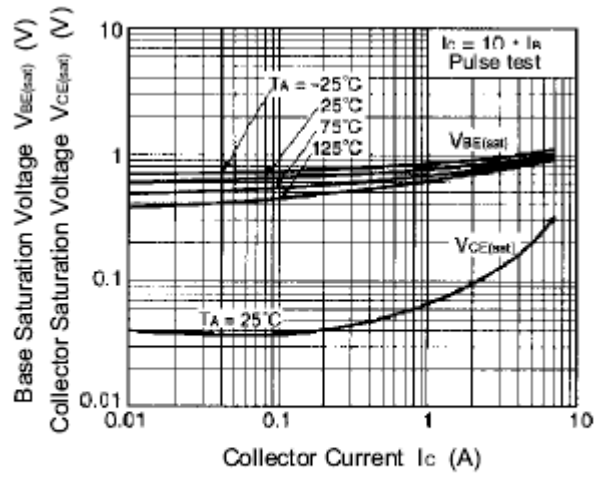

Fig.4 Base-Emitter Saturation Voltage
Collector-Emmitter Saturation Voltage

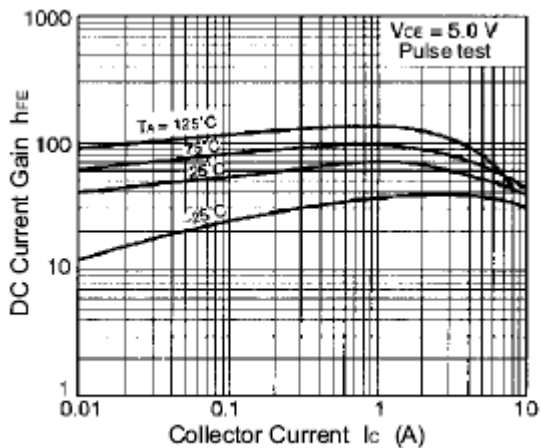

Fig.5 DC current Gain

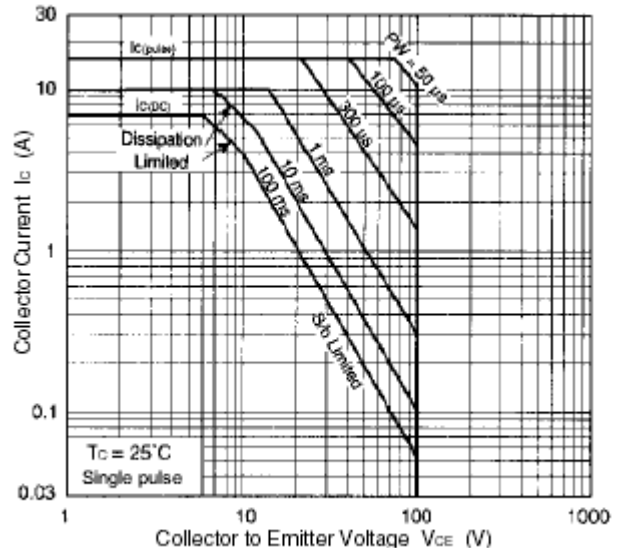

Fig.6 Safe Operating Area