

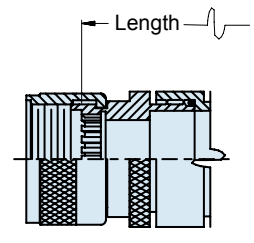

189-009 Banding Backshell / Molding Adapter For MIL-PRF-28876 Connectors

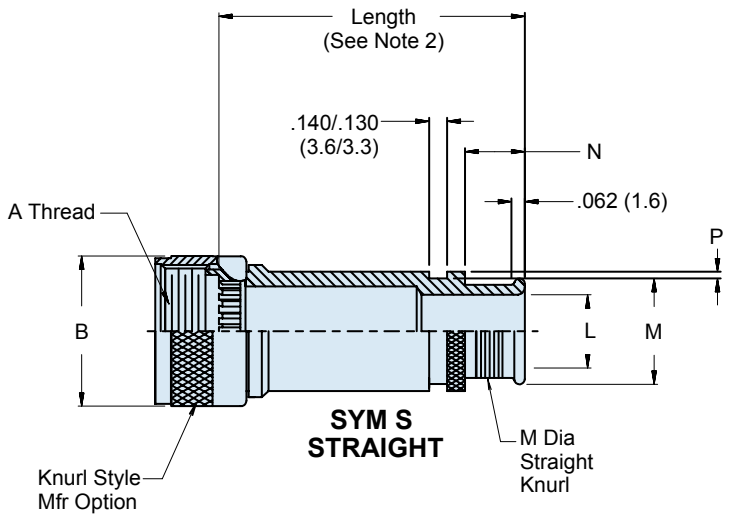

STYLE 2, SYM S
(See Note 3)

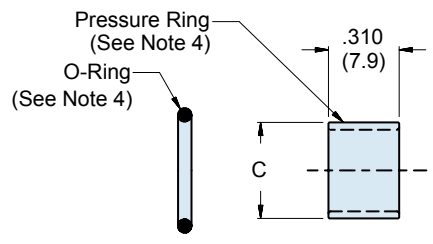
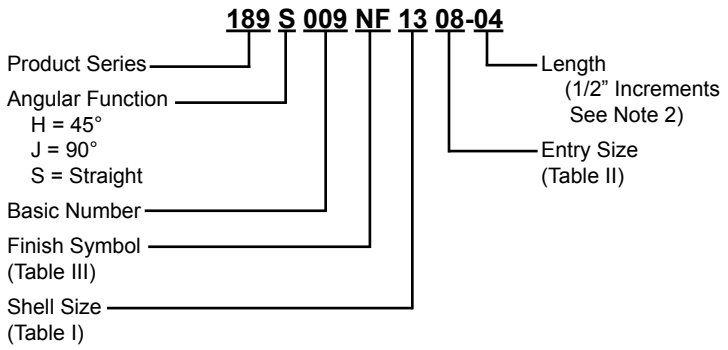
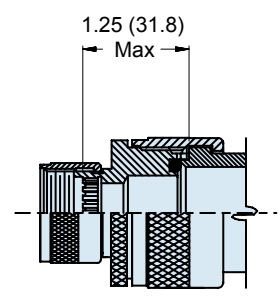

STYLE 2 45 & 90
(See Note 3)

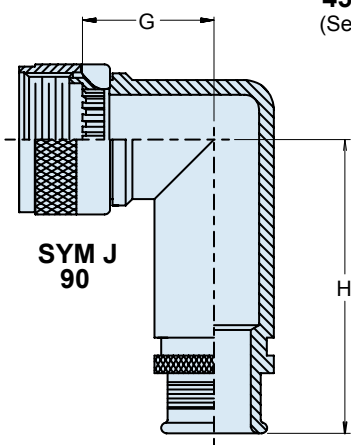
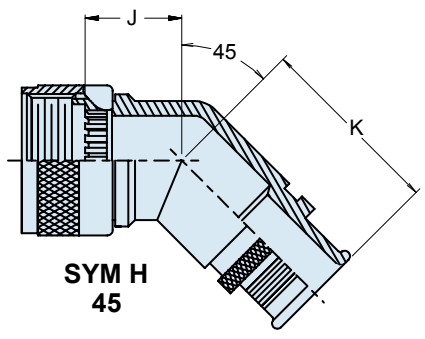

189-009
Banding Backshell / Molding Adapter
For MIL-PRF-28876 Connectors



TABLE I: SHELL SIZE

Shell Size	Connector Designator	A Thread UNEF	B Max	C Max	G Max	H Max	J Max	K Max	Max Entry
11	A	.750 - 20 UNEF	.960 (10.4)	.410 (10.4)	1.280 (32.5)	1.330 (3.8)	1.140 (29.0)	1.190 (30.2)	07
13	B	.875 - 20 UNEF	1.085 (27.6)	.532 (13.5)	1.350 (34.3)	1.400 (29.0)	1.170 (29.7)	1.220 (31.0)	08
15	C	1.000 - 20 UNEF	1.255 (31.9)	.710 (18.0)	1.430 (36.3)	1.470 (37.3)	1.200 (30.5)	1.250 (31.8)	10
23	F	1.437 - 18 UNEF	1.695 (43.1)	1.116 (28.3)	1.640 (41.7)	1.680 (42.7)	1.290 (32.8)	1.330 (33.8)	13

TABLE II: BACKSHELL DIMENSIONS

Dash No.	P Dim	L Dia	M Dia	N Dim
04	.044 (1.1)	.205 (5.2)	.325 (8.3)	.525 (13.3)
05	.044 (1.1)	.235 (6.0)	.355 (9.0)	.525 (13.3)
06	.044 (1.1)	.255 (6.5)	.375 (9.5)	.525 (13.3)
07	.044 (1.1)	.330 (8.4)	.450 (11.4)	.525 (13.3)
08	.044 (1.1)	.450 (11.4)	.580 (14.7)	.600 (15.2)
09	.044 (1.1)	.540 (13.7)	.660 (16.8)	.600 (15.2)
10	.044 (1.1)	.670 (17.0)	.790 (20.1)	.600 (15.2)
11	.044 (1.1)	.840 (21.3)	.960 (24.4)	.600 (15.2)
12	.069 (1.8)	.960 (24.4)	1.080 (27.4)	.600 (15.2)
13	.069 (1.8)	1.080 (27.4)	1.200 (30.5)	.600 (15.2)

TABLE III: FINISH

SYM	MATERIAL	FINISH
NF	Aluminum	Cadmium/Olive Drab over Electroless Nickel (500 Hr. Salt Spray)
B	Aluminum	Cadmium Plate/Olive Drab
J	Aluminum	Gold Iridite over Cadmium Plate over Nickel
N	Aluminum	Cadmium Plate/Olive Drab over Nickel
M	Aluminum	Electroless Nickel
T	Aluminum	Cadmium Plate/Bright Dip over Nickel

APPLICATION NOTES

1. Assembly identified with manufacturer's and P/N, space permitting.
2. Standard minimum length for style 1:1.5 inches, for style 2:2.0 inches. Note: Length applies to SYMS, straight, only.
3. When cable diameter exceeds inside diameter of connector shell, style 2 will be supplied.
4. Glenair 600 series Backshell Assy. tools are recommended for assembly and installation.
5. Material/ Finish: Adapters, Elbows, Coupling Nut, Pressure Ring—See Table III. O-Ring—Silicone/ N.A.
6. O-Ring & Pressure Ring to be packaged loose and must be installed with connector backend at time of assembly.
7. Metric dimensions (mm) are indicated in parentheses.