

# SKiiP 12NAB066V1

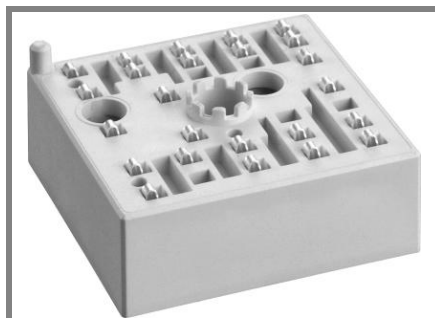

MiniSKiiP<sup>®</sup> 1

3-phase bridge rectifier +  
brake chopper + 3-phase  
bridge inverter  
SKiiP 12NAB066V1

Target Data

## Features

- Trench IGBTs
- Robust and soft freewheeling diodes in CAL technology
- Highly reliable spring contacts for electrical connections
- UL recognised file no. E63532

## Typical Applications

- Inverter up to 5 kVA
- Typical motor power 2,2 kW

## Remarks

- Case temperature limited to  $T_C = 125\text{ °C}$  max.

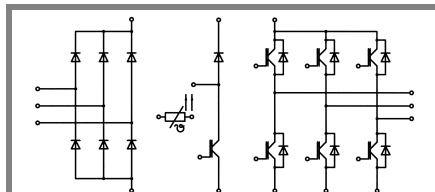

NAB

Absolute Maximum Ratings		$T_s = 25\text{ °C}$ , unless otherwise specified	
Symbol	Conditions	Values	Units
<b>IGBT - Inverter, Chopper</b>			
$V_{CES}$		600	V
$I_C$	$T_s = 25\text{ (70) °C}$		A
$I_{CRM}$	$T_s = 25\text{ (70) °C}$ , $t_p \leq 1\text{ ms}$		A
$V_{GES}$		$\pm 20$	V
$T_j$		- 40 ... + 175	°C
<b>Diode - Inverter, Chopper</b>			
$I_F$	$T_s = 25\text{ (70) °C}$		A
$I_{FRM}$	$T_s = 25\text{ (70) °C}$ , $t_p \leq 1\text{ ms}$		A
$T_j$		- 40 ... + 175	°C
<b>Diode - Rectifier</b>			
$V_{RRM}$		800	V
$I_F$	$T_s = 70\text{ °C}$	35	A
$I_{FSM}$	$t_p = 10\text{ ms}$ , $\sin 180\text{ °}$ , $T_j = 25\text{ °C}$	220	A
$i^2t$	$t_p = 10\text{ ms}$ , $\sin 180\text{ °}$ , $T_j = 25\text{ °C}$	240	A <sup>2</sup> s
$T_j$		- 40 ... + 150	°C
$I_{tRMS}$	per power terminal (20 A / spring)	20	A
$T_{stg}$	$T_{op} \leq T_{stg}$	- 40 ... + 125	°C
$V_{isol}$	AC, 1 min.	2500	V

Characteristics		$T_s = 25\text{ °C}$ , unless otherwise specified			
Symbol	Conditions	min.	typ.	max.	Units
<b>IGBT - Inverter, Chopper</b>					
$V_{CEsat}$	$I_C = 10\text{ A}$ , $T_j = 25\text{ (125) °C}$	1,45 (1,65)	1,9 (2,05)		V
$V_{GE(th)}$	$V_{GE} = V_{CE}$ , $I_C = 0,5\text{ mA}$	5,8			V
$V_{CE(TO)}$	$T_j = 25\text{ (125) °C}$	0,9 (0,85)	1 (0,9)		V
$r_T$	$T_j = 25\text{ (125) °C}$	55 (80)	90 (115)		mΩ
$C_{ies}$	$V_{CE} = 25\text{ V}$ , $V_{GE} = 0\text{ V}$ , $f = 1\text{ MHz}$	551			nF
$C_{oes}$	$V_{CE} = 25\text{ V}$ , $V_{GE} = 0\text{ V}$ , $f = 1\text{ MHz}$	40			nF
$C_{res}$	$V_{CE} = 25\text{ V}$ , $V_{GE} = 0\text{ V}$ , $f = 1\text{ MHz}$	17			nF
$R_{th(j-s)}$	per IGBT	1,5			K/W
$t_{d(on)}$	under following conditions	-			ns
$t_r$	$V_{CC} = 300\text{ V}$ , $V_{GE} = \pm 15\text{ V}$	-			ns
$t_{d(off)}$	$I_C = 10\text{ A}$ , $T_j = 125\text{ °C}$	-			ns
$t_f$	$R_{Gon} = R_{Goff} = -\Omega$	-			ns
$E_{on}$	inductive load	0,25			mJ
$E_{off}$		0,45			mJ
<b>Diode - Inverter, Chopper</b>					
$V_F = V_{EC}$	$I_F = 10\text{ A}$ , $T_j = 25\text{ (125) °C}$	1,4	1,6		V
$V_{(TO)}$	$T_j = 25\text{ (125) °C}$	0,95	1		V
$r_T$	$T_j = 25\text{ (125) °C}$	45	60		mΩ
$R_{th(j-s)}$	per diode	2,5			K/W
$I_{RRM}$	under following conditions	-			A
$Q_{rr}$	$I_F = 10\text{ A}$ , $V_R = 300\text{ V}$	-			μC
$E_{rr}$	$V_{GE} = 0\text{ V}$ , $T_j = 125\text{ °C}$ $di_F/dt = -\text{ A}/\mu\text{s}$	-			mJ
<b>Diode - Rectifier</b>					
$V_F$	$I_F = 15\text{ A}$ , $T_j = 25\text{ °C}$	1,1			V
$V_{(TO)}$	$T_j = 150\text{ °C}$	0,8			V
$r_T$	$T_j = 150\text{ °C}$	20			mΩ
$R_{th(j-s)}$	per diode	1,5			K/W
<b>Temperature Sensor</b>					
$R_{ts}$	3 %, $T_r = 25\text{ (100) °C}$	1000(1670)			Ω
<b>Mechanical Data</b>					
w		35			g
$M_s$	Mounting torque	2	2,5		Nm

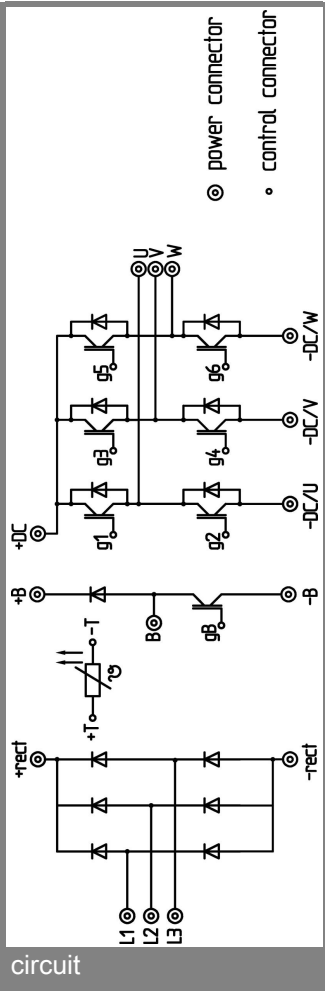

circuit

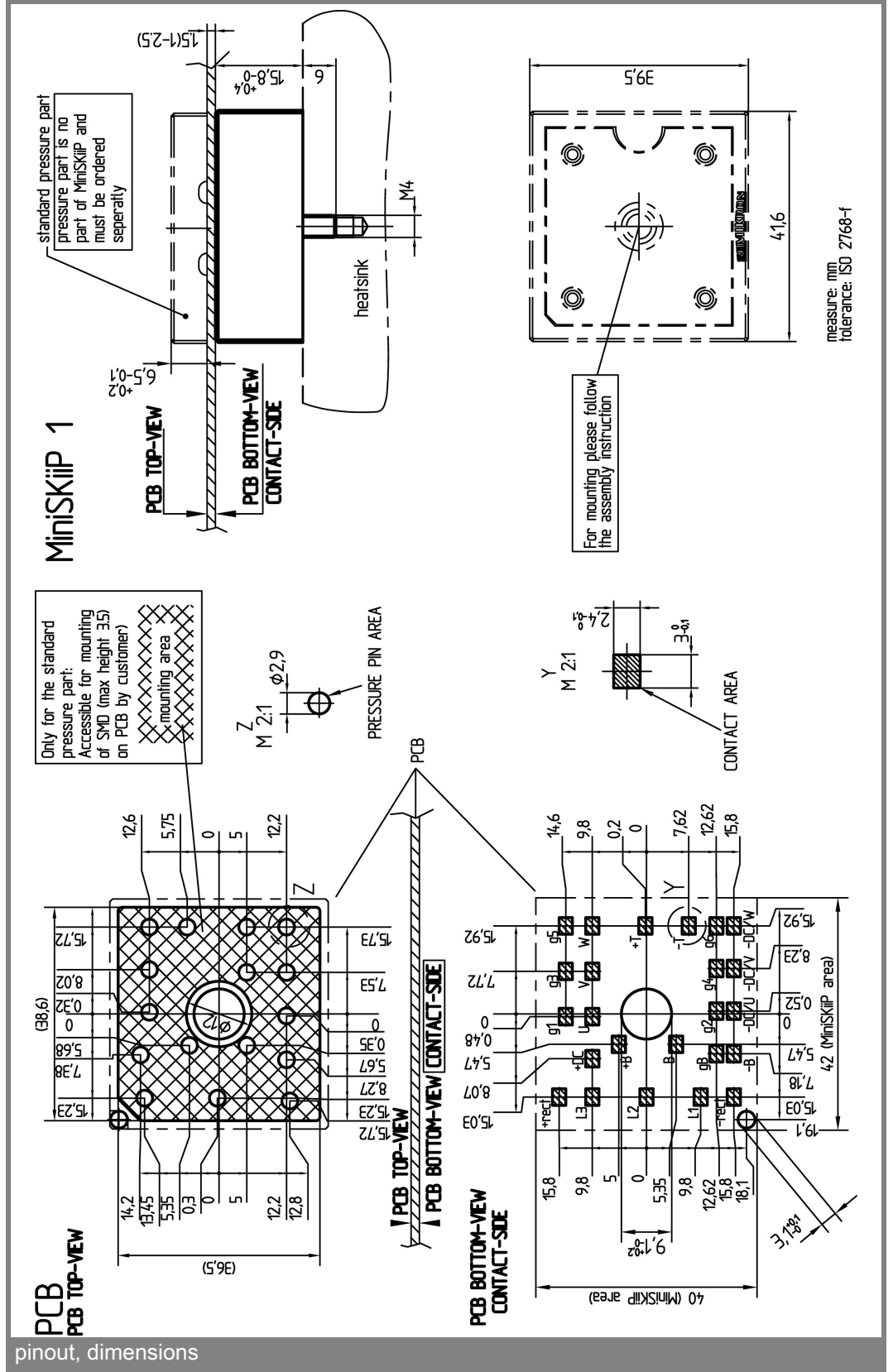

This is an electrostatic discharge sensitive device (ESDS), international standard IEC 60747-1, Chapter IX.

This technical information specifies semiconductor devices but promises no characteristics. No warranty or guarantee expressed or implied is made regarding delivery, performance or suitability.