

The ACTF4816B/479.5/T039-3 is a one channel IF filter for receivers of satellite broadcasting system.

1.Package Dimension (TO-39)

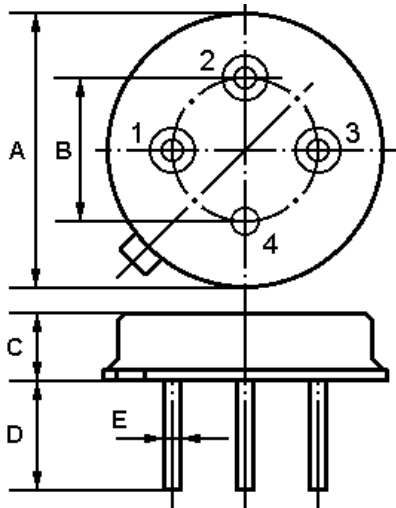

2.

Pin	Configuration
1	Input
2	Output
3	Output
4	Ground

Dimensions	Data (Unit: mm)
A	9.35±0.10
B	5.08±0.10
C	3.40±0.10
D	3.00±0.20
E	Φ0.45±0.20

3.Equivalent LC Model

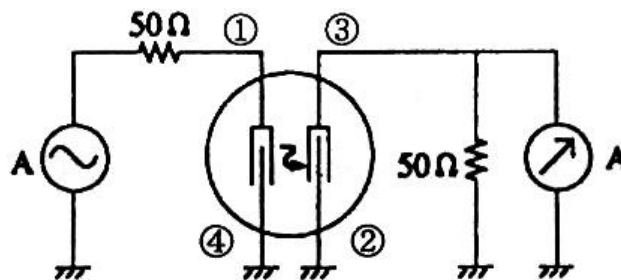

A : Network Analyzer

In keeping with our ongoing policy of product evolution and improvement, the above specification is subject to change without notice.

ISO9001: 2000 Registered - Registration number 6830/2

For quotations or further information please contact us at:

3 The Business Centre, Molly Millars Lane, Wokingham, Berks, RG41 2EY, UK

<http://www.actcrystals.com>

Issue : 1 C1

Date : SEPT 04

4. Typical Frequency Response

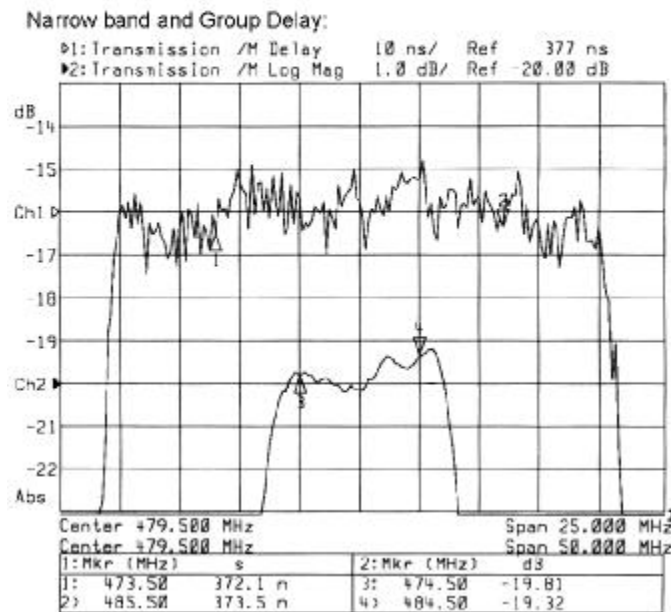
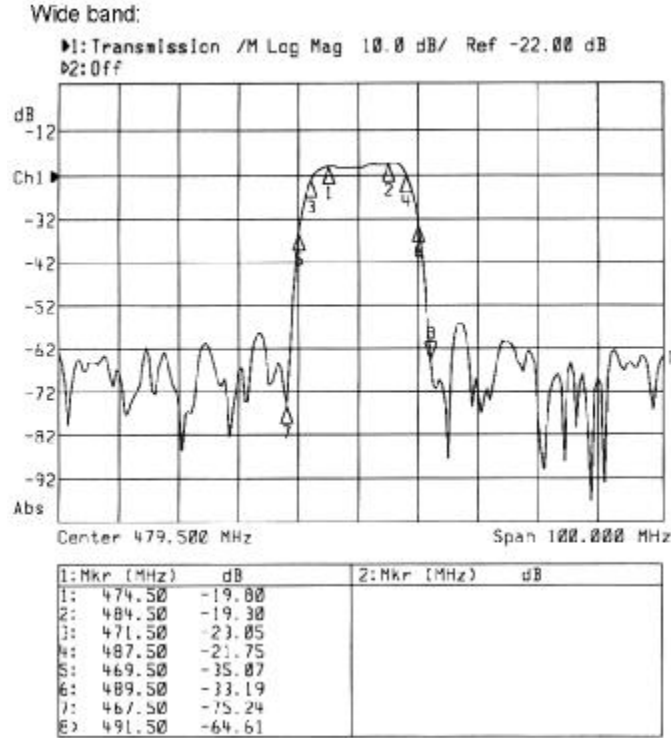

In keeping with our ongoing policy of product evolution and improvement, the above specification is subject to change without notice.

ISO9001: 2000 Registered - Registration number 6830/2

For quotations or further information please contact us at:

3 The Business Centre, Molly Millars Lane, Wokingham, Berks, RG41 2EY, UK

<http://www.actcrystals.com>

Issue : 1 C1

Date : SEPT 04

5.Performance

5-1.Maximum Ratings (Ta=25 °C)

Item	Electrode	Rating	Note
DC Voltage	Between input or output	10 V	
Instantaneous DC Voltage	Between any two electrodes	3 V	1/60s
Instantaneous AC Voltage	Between input or output	3 Vp-p	50/60Hz
Storage temperature range		-55 to +85°C	Tstg
Operable temperature range		-20 to +70°C	Topr

5-2.Electronic Characteristics

Reference temperature: $T_A = 25\text{ °C}$
 Terminating source impedance: $Z_S = 50\ \Omega$
 Terminating load impedance: $Z_L = 50\ \Omega$

Characteristic	Min.	Typ.	Max.	Units	
Centre Frequency f_c	--	479.50	--	MHz	
Insertion attenuation 479.50 MHz (Reference level for the following data)	α	--	22.0	24.0	dB
Pass bandwidth $\alpha_{rel} \leq 3\text{dB}$	$B_{3\text{dB}}$	--	15.8	--	MHz
Relative attenuation	α_{rel}				
467.50 MHz	--	-47	-30	dB	
469.50 MHz	--	-13	-10	dB	
471.50 MHz	-5	-2.5	--	dB	
487.50 MHz	-5	-4.0	--	dB	
489.50 MHz	--	-21	-10	dB	
491.50 MHz	--	-47	-30	dB	
Amplitude ripple (p-p) 474.50 ... 484.50 MHz	$\Delta \alpha$	--	0.6	1.5	dB
Group delay ripple (p-p) 473.50 ... 485.50 MHz (Delay Aperture=1.25MHz)	Δt	--	14	40	ns(p-p)
Temperature coefficient of frequency	TC_f	--	-18	--	ppm/K

In keeping with our ongoing policy of product evolution and improvement, the above specification is subject to change without notice.

ISO9001: 2000 Registered - Registration number 6830/2

Issue : 1 C1

For quotations or further information please contact us at:

Date : SEPT 04

3 The Business Centre, Molly Millars Lane, Wokingham, Berks, RG41 2EY, UK

<http://www.actcrystals.com>

6. Reliability Test

6.1 Life Test

Item	Test Condition	Limit
High Temperature Exposure	Tstg Max.(85°C),500h	$\Delta f_o \leq \pm 0.5\%$ (Δf_o : Deviation of centre frequency fo)
High Temperature Operation	Topr Max.(70°C),DC 0.5V (In or Out),500h	
Low Temperature Exposure	Tstg Min.(-55°C),500h	
Moisture Resistance	Ta=60• ,RH=90%,500H	

6.2 Environmental Test

Item	Test Condition	Limit
TCT	(-20°C 30min. → 25°C 5min. → 80°C 30min. → 25°C 5min.), 5 cycles	Same as 6.1
Soldering	Immerse the pins in melt solder at 230±5°C for 5 seconds.	More than 95% of total area of the pins should be covered with solder
Heat Resistivity for Melt Solder	Set on PC board, immerse in melt solder at 260±5°C for 6±2 seconds.	Same as 6.1

6.3 Mechanical Test

Item	Test Condition	Limit
Drop	On maple plate from 1m high,3times.	Same as 6.1
Lead Bend	$\pi/2$ rad bending, with 4.4N weight,2 times.	
Lead Pull	After bending lead parallel to heater base, pull with 9.8N force for 1 minute.	

In keeping with our ongoing policy of product evolution and improvement, the above specification is subject to change without notice.

ISO9001: 2000 Registered - Registration number 6830/2

For quotations or further information please contact us at:

3 The Business Centre, Molly Millars Lane, Wokingham, Berks, RG41 2EY, UK

<http://www.actcrystals.com>

Issue : 1 C1

Date : SEPT 04

i CAUTION: Electrostatic Sensitive Device. Observe precautions for handling!

1. The frequency f_c is defined as the midpoint between the 3dB frequencies.
2. Unless noted otherwise, all measurements are made with the filter installed in the specified test fixture that is connected to a 50Ω test system with $VSWR \leq 1.2:1$. The test fixture L and C are adjusted for minimum insertion loss at the filter centre frequency, f_c . Note that insertion loss, bandwidth, and passband shape are dependent on the impedance matching component values and quality.
3. Unless noted otherwise, specifications apply over the entire specified operating temperature range.
4. The specifications of this device are based on the test circuit shown above and subject to change or obsolescence without notice.
5. All equipment designs utilizing this product must be approved by the appropriate government agency prior to manufacture or sale.
6. Our liability is only assumed for the Surface Acoustic Wave (SAW) component(s) per se, not for applications, processes and circuits implemented within components or assemblies.

In keeping with our ongoing policy of product evolution and improvement, the above specification is subject to change without notice.

ISO9001: 2000 Registered - Registration number 6830/2

For quotations or further information please contact us at:

3 The Business Centre, Molly Millars Lane, Wokingham, Berks, RG41 2EY, UK

<http://www.actcrystals.com>

Issue : 1 C1

Date : SEPT 04