

CMOS Temperature Sensor

GENERAL DESCRIPTION

The XC31B series are ultra small CMOS temperature sensor ICs. As a bandgap type temperature sensor is built-into the XC31B, linearity, in comparison to thermistor type temperature sensors, is much better.

The operating temperature range of the series is from -30 to +80 . The XC31B comes in a mini molded SOT-25 and USP-6B packages with a supply current of only 7 μ A

(@V_{OUT}=2.0V) and as such, is suitable for use with various portable devices. Output voltage is selectable in 100mV increments within a range of 2.0V to 6.0V (at 25).

APPLICATIONS

- Mobile phones
- Portable AV equipment
- Palm top computers, PDAS
- Battery powered equipment

FEATURES

- Operating Voltage Range** : 3.0V ~ 10.0V
- Output Voltage Range** : 2.0V~ 6.0V
- Output Voltage Accuracy** : $\pm 3\%$
- Detectable Temperature Range** : -30 ~ +80
- Output Voltage Temp. Coefficient**: -3900ppm/ (TYP.)
- Low Power Consumption** : 7 μ A (@V_{OUT}=2.0V)
- Packages** : SOT-25, USP-6B

PIN CONFIGURATION

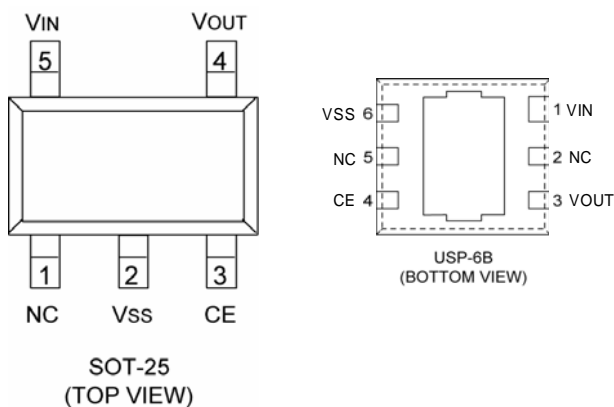

PIN ASSIGNMENT

PIN NUMBER		PIN NAME	FUNCTION
SOT25	USP-6B		
1	2, 5	NC	No Connection
2	6	VSS	Ground
3	4	CE	Chip Enable
4	3	VOUT	Output
5	1	VIN	Power Supply

*The dissipation pad for the USP-6B package should be solder-plated in recommended mount pattern and metal masking so as to enhance mounting strength and heat release.
If the pad needs to be connected to other pins, it should be connected to the Vss pin.

PRODUCT CLASSIFICATION

Ordering Information

XC31B

DESIGNATOR	DESCRIPTION	SYMBOL	DESCRIPTION
	Polarity of Output Voltage	P	: + (Positive)
	Temperature Coefficient	N	: - (Negative)
	Output Voltage (25 °C)	20~60	: e.g. 20=2.0V, 30=3.0V
	Revision Character	A ~	: -
	Package	M	: SOT-25 (SOT-23-5)
		D	: USP-6B
	Device Orientation	R	: Embossed tape, standard feed
		L	: Embossed tape, reverse feed

BLOCK DIAGRAM

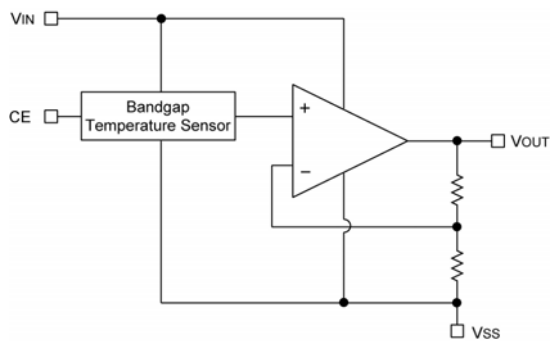

ABSOLUTE MAXIMUM RATINGS

Ta=25 °C, Vss=0V

PARAMETER	SYMBOL	RATINGS	UNIT
Input Voltage	V _{IN}	- 0.3 ~ 12	V
Output Voltage	V _{OUT}	- 0.3 ~ 12	V
CE Pin Voltage	V _{CE}	- 0.3 ~ V _{IN} +0.3	V
Output Current	I _{OUT}	20	mA
Power Dissipation	SOT-25	P _d	mW
	USP-6B		
Operating Temperature Range	T _{opr}	- 40 ~ +85	
Storage Temperature Range	T _{stg}	- 40 ~ +125	

ELECTRICAL CHARACTERISTICS

XC31BPN20A $V_{OUT(T)}^{(*)1} = 2.0V$

PARAMETER	SYMBOL	CONDITIONS	MIN.	TYP.	MAX.	UNITS
Input Voltage	V _{IN}		-	-	10	V
Output Voltage	V _{OUT}	I _{OUT} =100 μA ^{(*)2} , V _{IN} =4.0V, T _a =25	1.94	2.0	2.06	V
Detectable Temperature Range			-30	-	+80	
Output Voltage Temperature Coefficient	T _D ^{(*)3}	I _{OUT} =100 μA, V _{IN} =4.0V -30 Ta 80	-3400	-3900	-4400	ppm/
Temperature Sensitivity	T _{SE}	-30 Ta 80	-6.8	-7.8	-8.8	mV/
Linearity Margin Error	T _L ^{(*)4}	-30 Ta 80	-	1	3.5	%
Load Regulation	V _{OUT}	V _{IN} =4.0V 1 μA I _{OUT} 100 μA	-	2.0	-	mV
Supply Current 1	I _{SS1}	V _{IN} =V _{CE} =4.0V, T _a =25	-	7	17	μA
Supply Current 2	I _{SS2}	V _{IN} =4.0V, V _{CE} =V _{SS} , T _a =25	-	-	0.1	μA
CE "High" Level Voltage	V _{CEH}		1.5	-	-	V
CE "Low" Level Voltage	V _{CEL}		-	-	0.3	V

XC31BPN40A $V_{OUT(T)}^{(*)1} = 4.0V$

PARAMETER	SYMBOL	CONDITIONS	MIN.	TYP.	MAX.	UNITS
Input Voltage	V _{IN}		-	-	10	V
Output Voltage	V _{OUT}	I _{OUT} =100 μA ^{(*)2} , V _{IN} =6.0V, T _a =25	3.88	2.0	4.12	V
Detectable Temperature Range			-30	-	+80	
Output Voltage Temperature Coefficient	T _D ^{(*)3}	I _{OUT} =100 μA, V _{IN} =6.0V -30 Ta 80	-3400	-3900	-4400	ppm/
Temperature Sensitivity	T _{SE}	-30 Ta 80	-13.6	-15.6	-17.6	mV/
Linearity Margin Error	T _L ^{(*)4}	-30 Ta 80	-	1	3.5	%
Load Regulation	V _{OUT}	V _{IN} =6.0V 1 μA I _{OUT} 100 μA	-	3.0	-	mV
Supply Current 1	I _{SS1}	V _{IN} =V _{CE} =6.0V, T _a =25	-	8	18	μA
Supply Current 2	I _{SS2}	V _{IN} =6.0V, V _{CE} =V _{SS} , T _a =25	-	-	0.1	μA
CE "High" Level Voltage	V _{CEH}		1.5	-	-	V
CE "Low" Level Voltage	V _{CEL}		-	-	0.3	V

NOTE:

*1: $V_{OUT(T)}$ = Specified output voltage at 25 °C.

*2: When output current exceed 100 μA, output voltage drop will increase.

If this IC is to be used in applications where such currents are required, please use a buffer on the output

*3: Output voltage temperature coefficient (T_D) is defined as:

$$T_D = \frac{\Delta V_{OUT}}{T_a \cdot V_{OUT}}$$

*4: Linearity margin error (T_L) is calculated as follows:

$$T_L = \frac{e_{max}}{T_{se} \cdot \Delta T_a}$$

where e_{max} = maximum error.

The maximum error is the maximum difference between the actual measured value and the value on an approximated straight line.

TYPICAL APPLICATION CIRCUIT

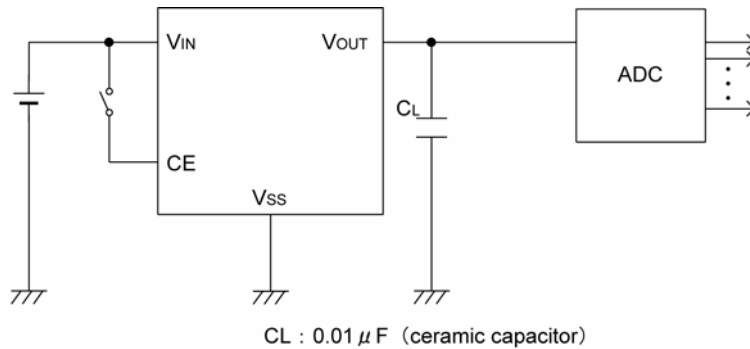

NOTE ON USE

1. When the load capacitance C_L is too large, oscillation may occur on the output signal.
2. Output signal overshoot will occur when the power (V_{IN}) is switched on or when the power drastically fluctuates. The chip enable (CE) function is effective for helping to avoid overshoot and also in saving consumption current.

TYPICAL PERFORMANCE CHARACTERISTICS

(1) Output Voltage vs. Ambient Temperature

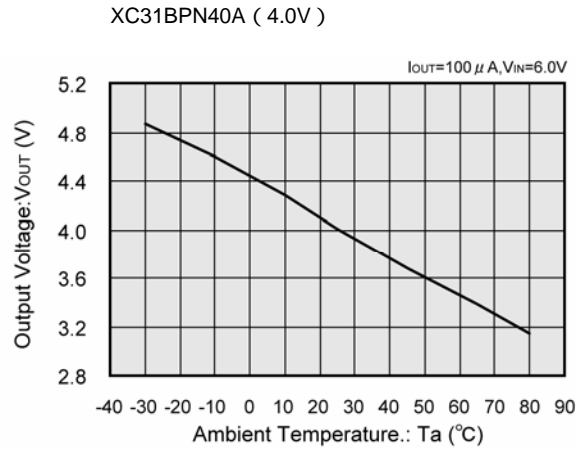
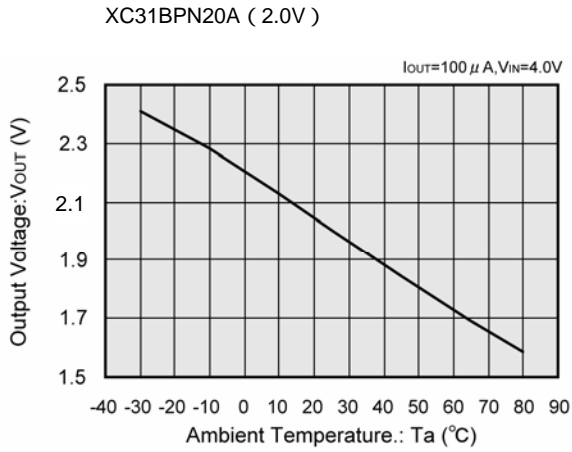

(2) Supply Current vs. Ambient Temperature

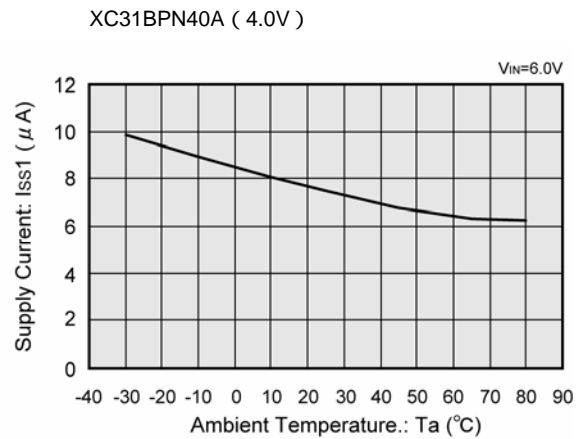
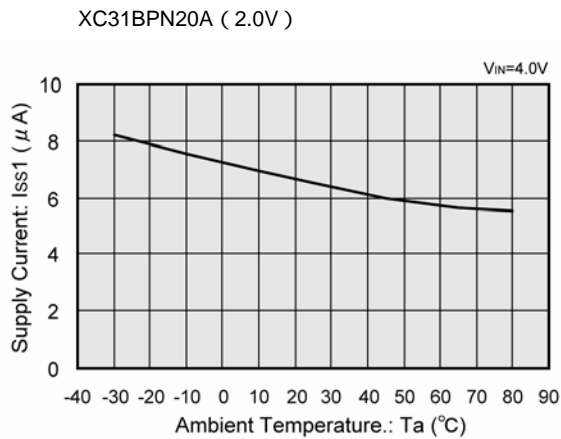

(3) Output Voltage vs. Input Voltage

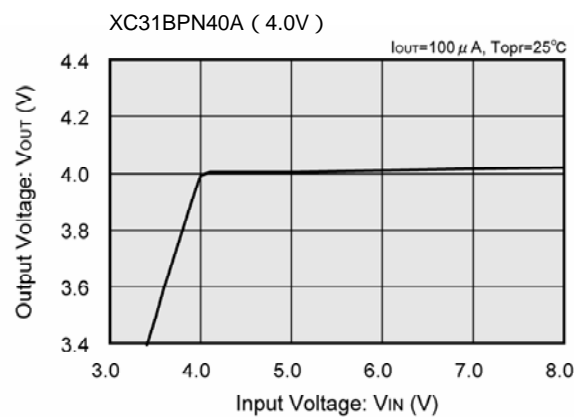
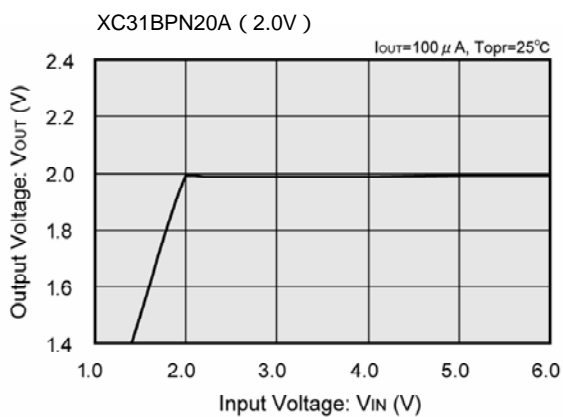

TYPICAL PERFORMANCE CHARACTERISTICS(Continued)

(4) Input Transient Response 1

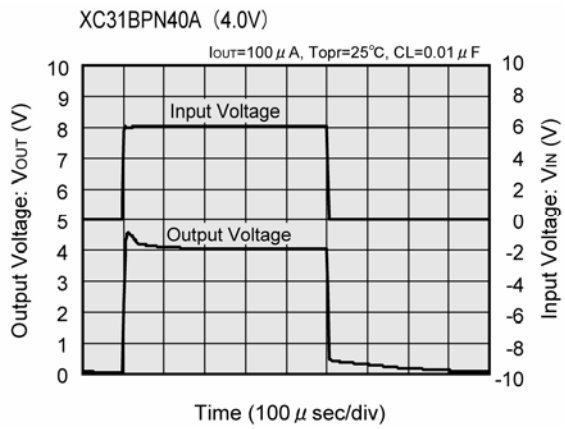
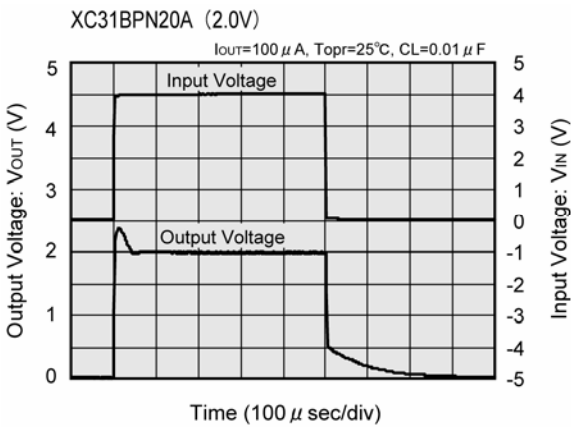

(5) Input Transient Response 2

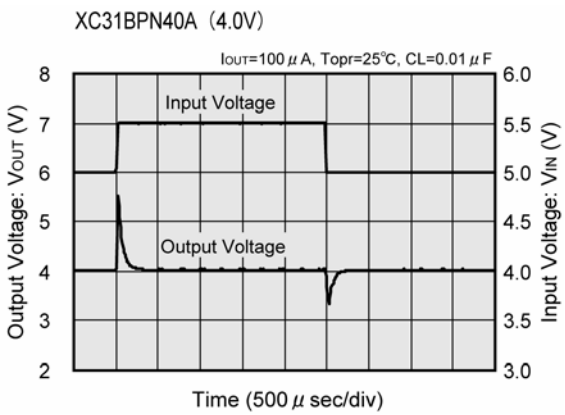
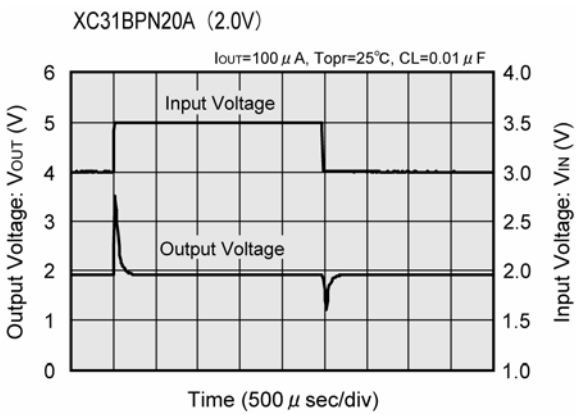

(6) CE Pin Transient Response

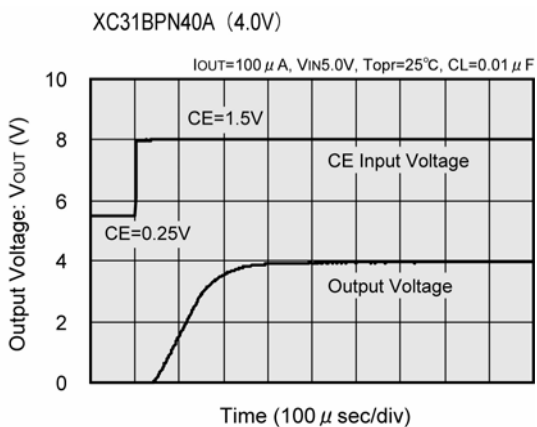
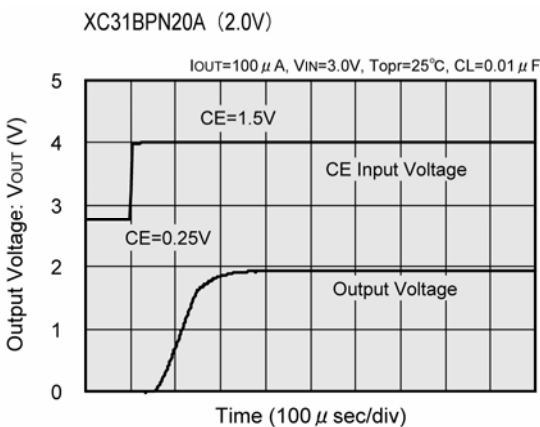

TYPICAL PERFORMANCE CHARACTERISTICS(Continued)

(7) Ripple Rejection Rate

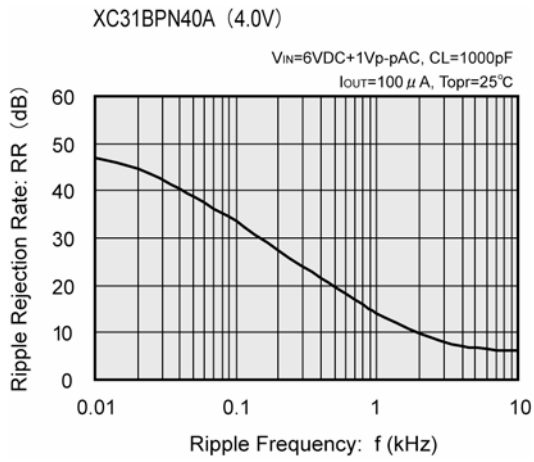

PACKAGING INFORMATION

SOT-25

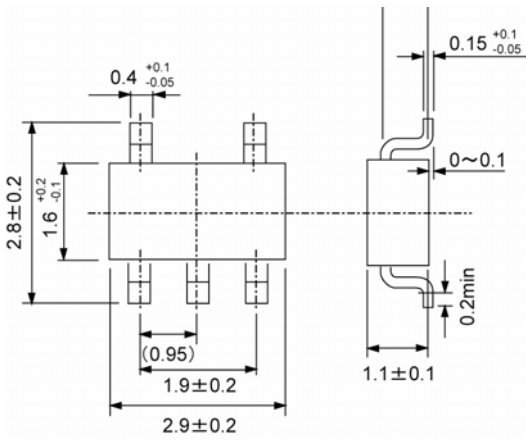

USP-6B

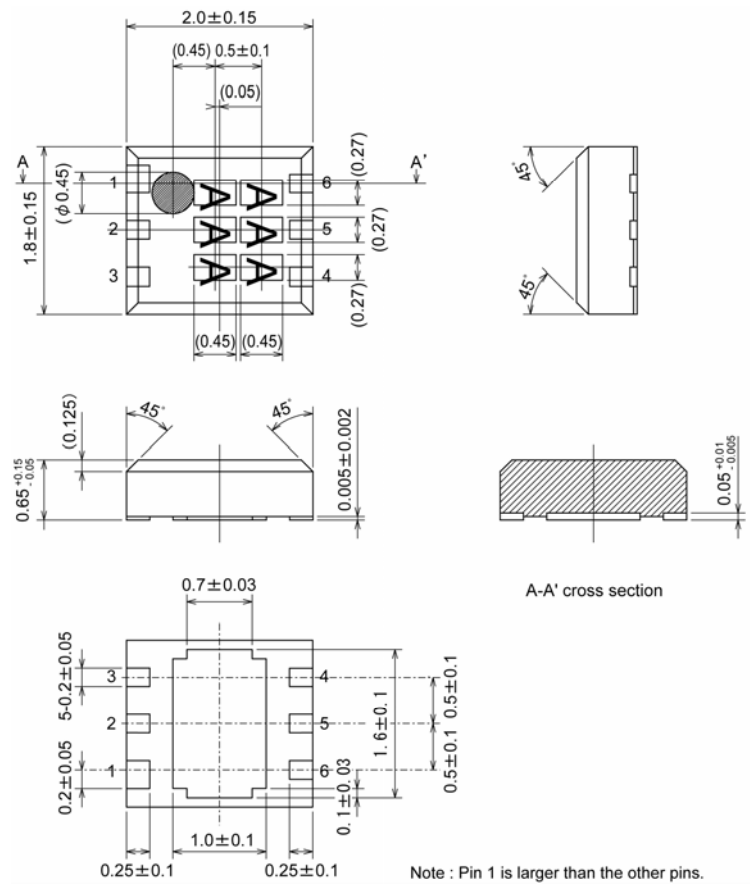

PACKAGING INFORMATION (Continued)

USP-6B Recommended Pattern Layout

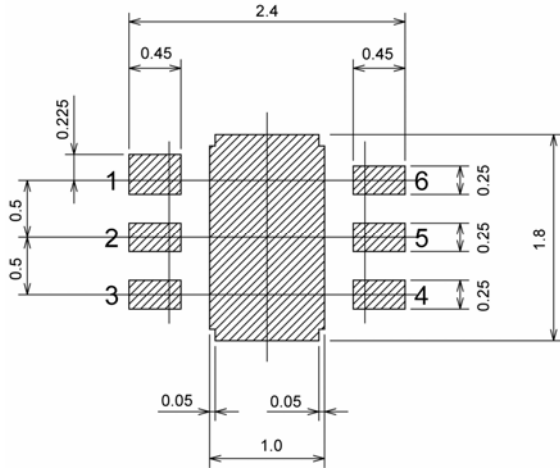

USP-6B Recommended Metal Mask Design

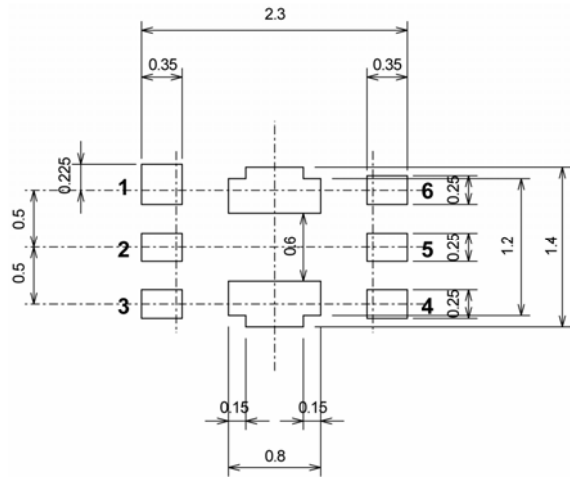

MARKING RULE

SOT-25

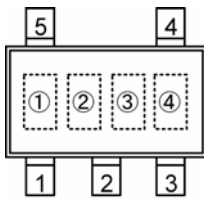

SOT-25
(TOP VIEW)

Based on internal standards

Represents integer of output voltage

MARK	VOLTAGE (V)
2	2.x
3	3.x
4	4.x
5	5.x
6	6.x

Represents decimal number point of output voltage

MARK	VOLTAGE (V)
0	x.0
1	x.1
2	x.2
3	x.3
4	x.4
5	x.5
6	x.6
7	x.7
8	x.8
9	x.9

Represents assembly lot number
(Based on internal standards)

1. The products and product specifications contained herein are subject to change without notice to improve performance characteristics. Consult us, or our representatives before use, to confirm that the information in this catalog is up to date.
2. We assume no responsibility for any infringement of patents, patent rights, or other rights arising from the use of any information and circuitry in this catalog.
3. Please ensure suitable shipping controls (including fail-safe designs and aging protection) are in force for equipment employing products listed in this catalog.
4. The products in this catalog are not developed, designed, or approved for use with such equipment whose failure of malfunction can be reasonably expected to directly endanger the life of, or cause significant injury to, the user.
(e.g. Atomic energy; aerospace; transport; combustion and associated safety equipment thereof.)
5. Please use the products listed in this catalog within the specified ranges.
Should you wish to use the products under conditions exceeding the specifications, please consult us or our representatives.
6. We assume no responsibility for damage or loss due to abnormal use.
7. All rights reserved. No part of this catalog may be copied or reproduced without the prior permission of Torex Semiconductor Ltd.

TOREX SEMICONDUCTOR LTD.