



# PART NUMBERING GUIDE

## E1WSDA12 - 32.768K TR

### PACKAGE OPTIONS

Blank=Bulk, TR=Tape and Reel

## NOTES

### MECHANICAL DIMENSIONS ALL DIMENSIONS IN MILLIMETERS

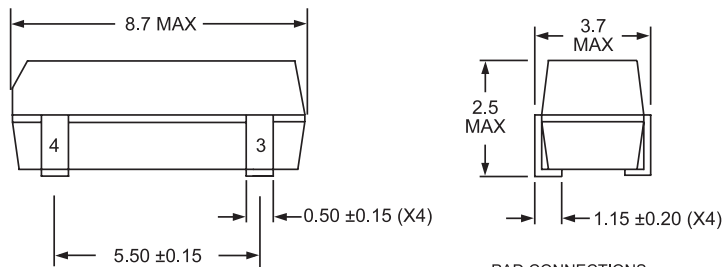

#### PAD CONNECTIONS

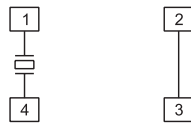

### SUGGESTED SOLDER PAD LAYOUTS ALL DIMENSIONS IN MILLIMETERS

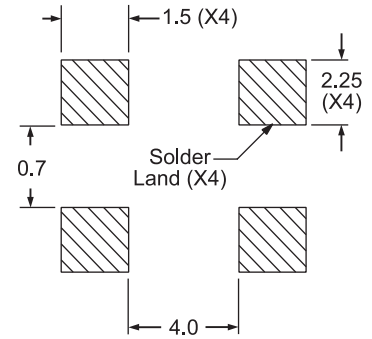

### TAPE AND REEL DIMENSIONS ALL DIMENSIONS IN MILLIMETERS

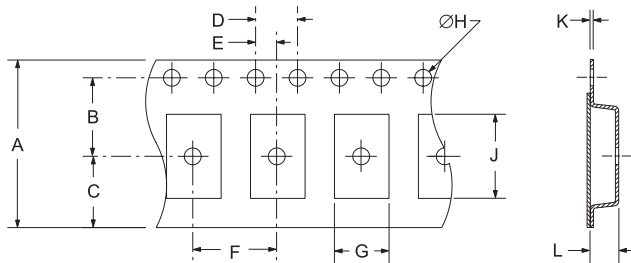

TAPE	A	B	C	D	E	
	16±.3	7.5±.1	6.75±.1	4±.2	2±.1	
	F	G	H	J	K	L
	8±.2	4.35±.1	1.5+-.2-.1	10.7±.2	.5±.05	3.7±.2

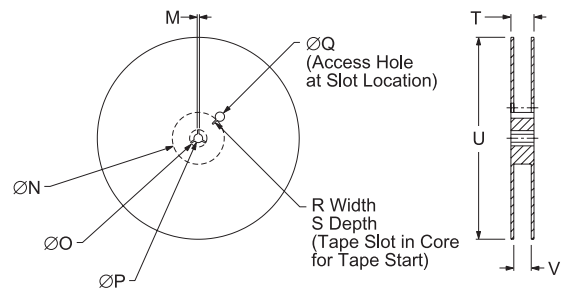

REEL	M	N	O	P	Q	
	1.5 MIN	50 MIN	20.2 MIN	13±.2	40 MIN	
	R	S	T	U	V	QTY/REEL
	2.5 MIN	10 MIN	22.4 MAX	360 MAX	16.4+2-0	3,000

### PARABOLIC TEMPERATURE CURVE

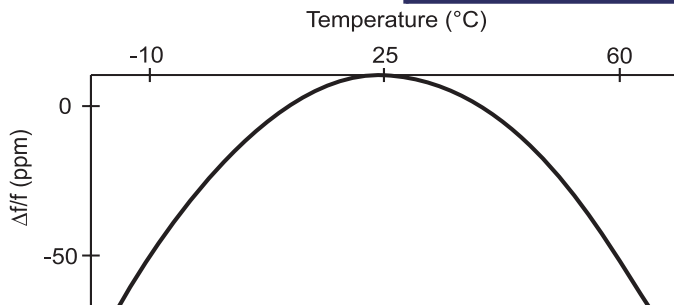

### MARKING SPECIFICATIONS

Line 1: C2K XXXX  
 Lot Identifier (4 or 5 Characters)  
 Frequency Code

MANUFACTURER  
ECLIPTEK CORP.

CATEGORY  
CRYSTAL

SERIES  
E1WS

PACKAGE  
PLASTIC

CLASS  
CR47

REV. DATE  
05/05