

Typical Applications

- Broadband, Low Noise Gain Blocks
- IF or RF Buffer Amplifiers
- Driver Stage for Power Amplifiers
- Final PA for Low Power Applications
- High Reliability Applications
- Broadband Test Equipment

Product Description

The RF2046 is a general purpose, low cost RF amplifier IC. The device is manufactured on an advanced Gallium Arsenide Heterojunction Bipolar Transistor (HBT) process, and has been designed for use as an easily-cascadable 50Ω gain block. Applications include IF and RF amplification in wireless voice and data communication products operating in frequency bands up to 3000MHz. The device is self-contained with 50Ω input and output impedances and requires only two external DC biasing elements to operate as specified. With a goal of enhanced reliability, the extremely small Micro-X ceramic package offers significantly lower thermal resistance than similar size plastic packages.

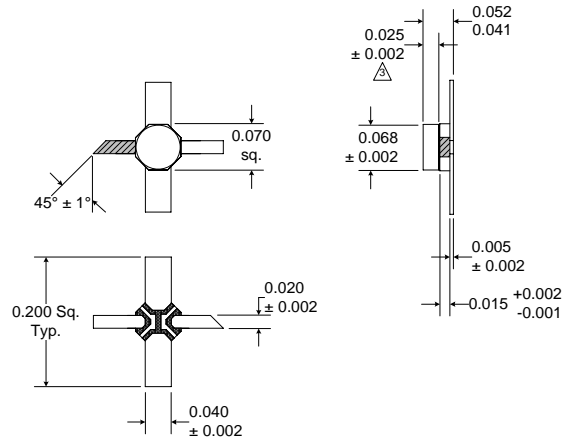

- NOTES:**
1. Shaded lead is pin 1.
 2. Darkened areas are metallization.
 3. Dimension applies to ceramic lid minus epoxy coating.

Optimum Technology Matching® Applied

- | | | |
|-------------------------------------|--|---------------------------------------|
| <input type="checkbox"/> Si BJT | <input checked="" type="checkbox"/> GaAs HBT | <input type="checkbox"/> GaAs MESFET |
| <input type="checkbox"/> Si Bi-CMOS | <input type="checkbox"/> SiGe HBT | <input type="checkbox"/> Si CMOS |
| <input type="checkbox"/> InGaP/HBT | <input type="checkbox"/> GaN HEMT | <input type="checkbox"/> SiGe Bi-CMOS |

Package Style: Micro-X Ceramic

Features

- DC to 3000MHz Operation
- Internally matched Input and Output
- 22dB Small Signal Gain
- 3.0dB Noise Figure
- 10mW Linear Output Power
- Single Positive Power Supply

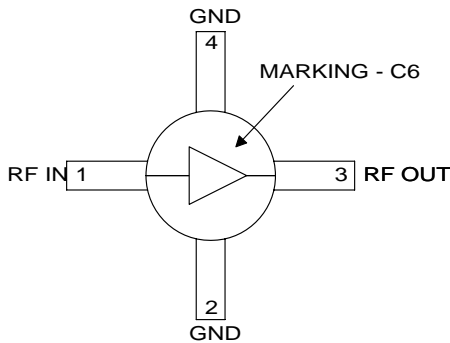

Functional Block Diagram

Ordering Information

RF2046 General Purpose Amplifier
 RF2046PCBA-41X Fully Assembled Evaluation Board

RF Micro Devices, Inc.
 7628 Thorndike Road
 Greensboro, NC 27409, USA

Tel (336) 664 1233
 Fax (336) 664 0454
<http://www.rfmd.com>

RF2046

Absolute Maximum Ratings

Parameter	Rating	Unit
Input RF Power	+13	dBm
Operating Ambient Temperature	-40 to +85	°C
Storage Temperature	-60 to +150	°C



Caution! ESD sensitive device.

RF Micro Devices believes the furnished information is correct and accurate at the time of this printing. However, RF Micro Devices reserves the right to make changes to its products without notice. RF Micro Devices does not assume responsibility for the use of the described product(s).

Parameter	Specification			Unit	Condition
	Min.	Typ.	Max.		
Overall					T=25 °C, V _D =3.5V, I _{CC} =35mA
Frequency Range		DC to 3000		MHz	
Gain		22.7		dB	Freq=100MHz
		22.1		dB	Freq=1000MHz
	18	21.0		dB	Freq=2000MHz
		19.2		dB	Freq=3000MHz
Gain Flatness		±0.9		dB	100MHz to 2000MHz
Noise Figure		2.7		dB	Freq=2000MHz
Input VSWR		<2.0:1			In a 50Ω system, DC to 3000MHz
Output VSWR		<1.9:1			In a 50Ω system, DC to 3000MHz
Output IP ₃		+23.5		dBm	Freq=2000MHz±100kHz, P _{TONE} =-18dBm
Output P _{1dB}		+10.7		dBm	Freq=2000MHz
Reverse Isolation		22.8		dB	Freq=2000MHz
Thermal					I _{CC} =35mA, P _{DISS} =116mW (See Note 1.)
Theta _{JC}		275		°C/W	
Maximum Measured Junction Temperature at DC Bias Conditions		117		°C	
Mean Time To Failure (MTTF)		280,000		years	T _{AMB} =+85°C
Power Supply					With 22Ω bias resistor, T=+25°C
Device Operating Voltage	3.0	3.5	4.0	V	At pin 3 with I _{CC} =35mA
	3.6	4.3	4.6	V	At evaluation board connector, I _{CC} =35mA
Operating Current			35	mA	See Note 2.

NOTES:

Note 1: The RF2046 must be operated at or below 35mA in order to achieve the thermal performance stated above. Operating at 35mA will ensure the best possible combination of reliability and electrical performance.

Note 2: Because of process variations from part to part, the current resulting from a fixed bias voltage will vary. As a result, caution should be used in designing fixed voltage bias circuits to ensure the worst case bias current does not exceed 35mA over all intended operating conditions.

Pin	Function	Description	Interface Schematic
1	RF IN	RF input pin. This pin is NOT internally DC-blocked. A DC-blocking capacitor, suitable for the frequency of operation, should be used in most applications. DC-coupling of the input is not allowed, because this will override the internal feedback loop and cause temperature instability.	
2	GND	Ground connection. For best performance, keep traces physically short and connect immediately to ground plane.	
3	RF OUT	RF output and bias pin. Biasing is accomplished with an external series resistor and choke inductor to V_{CC} . The resistor is selected to set the DC current into this pin to a desired level. The resistor value is determined by the following equation: $R = \frac{(V_{SUPPLY} - V_{DEVICE})}{I_{CC}}$ <p>Care should also be taken in the resistor selection to ensure that the current into the part never exceeds 35mA over the planned operating temperature. This means that a resistor between the supply and this pin is always required, even if a supply near 3.5V is available, to provide DC feedback to prevent thermal runaway. Because DC is present on this pin, a DC-blocking capacitor, suitable for the frequency of operation, should be used in most applications. The supply side of the bias network should also be well bypassed.</p>	
4	GND	Same as pin 2.	

Application Schematic

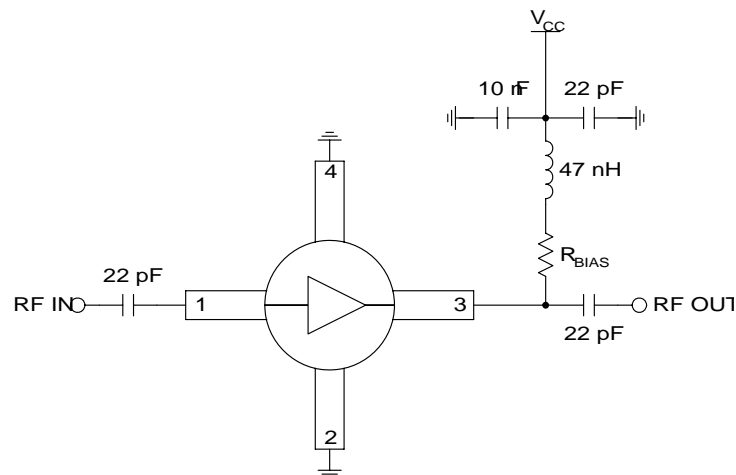

Evaluation Board Schematic

(Download [Bill of Materials](http://www.rfmd.com) from www.rfmd.com.)

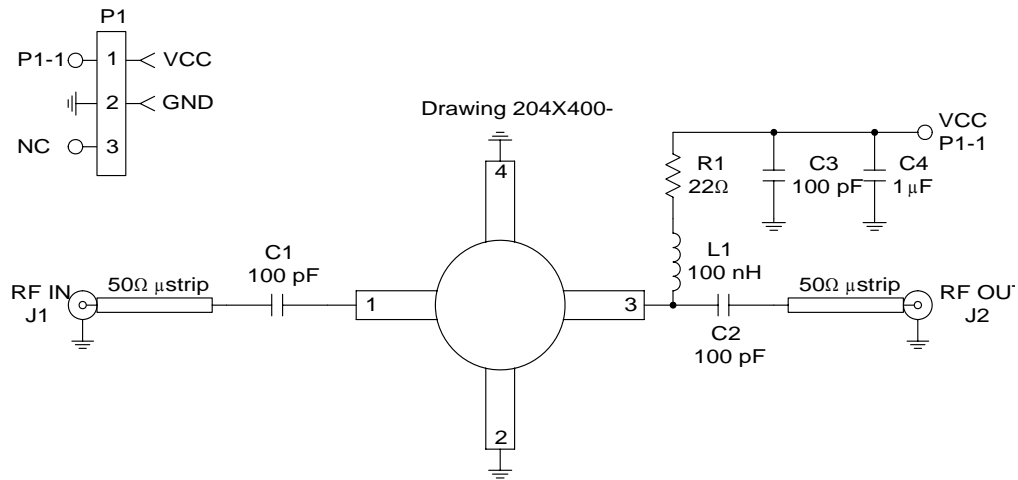

Evaluation Board Layout Board Size 1.195" x 1.000"

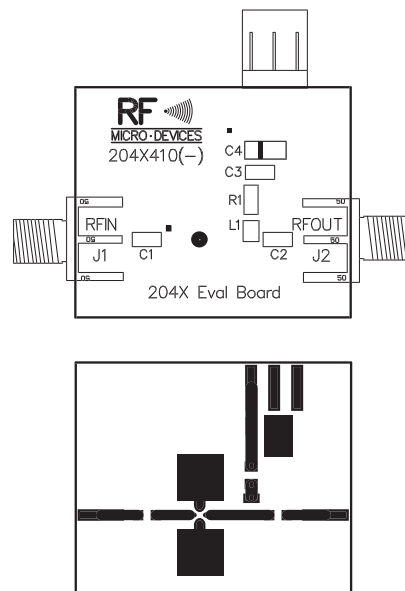

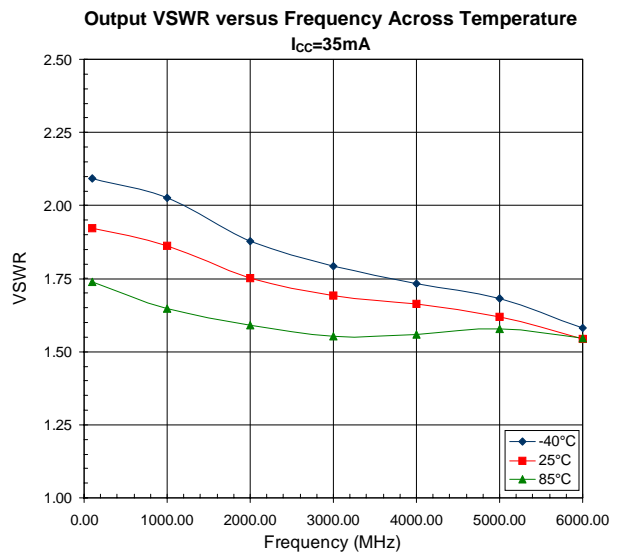
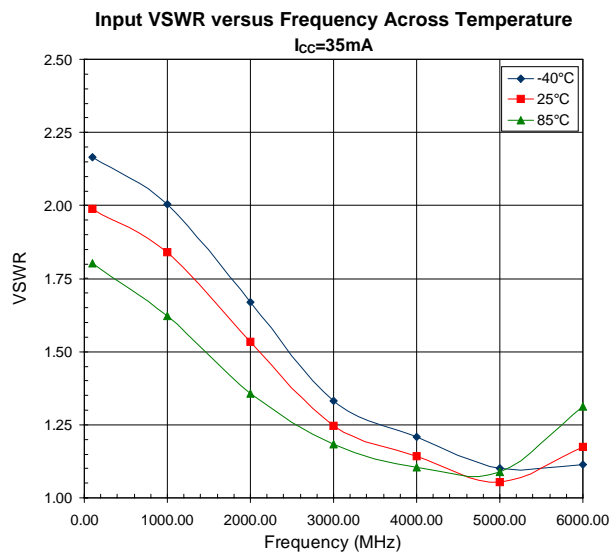
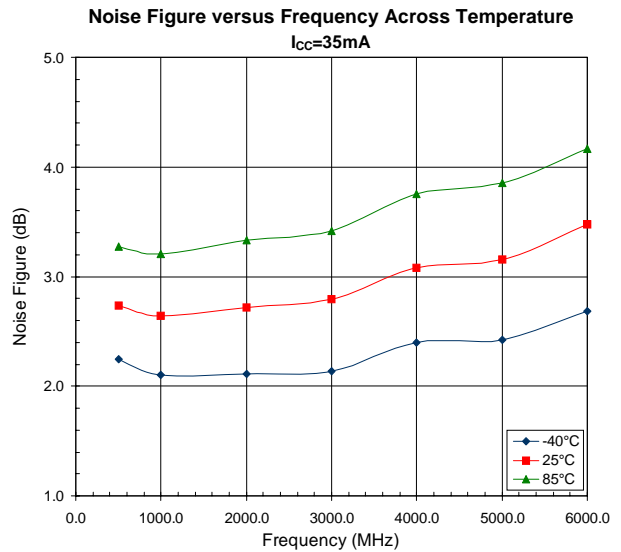
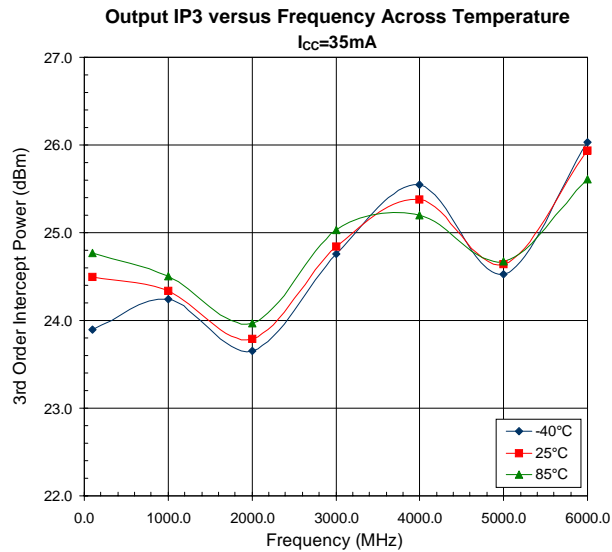
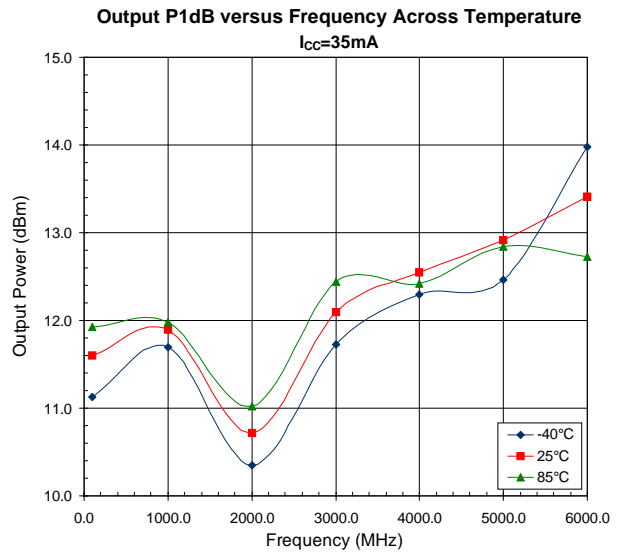
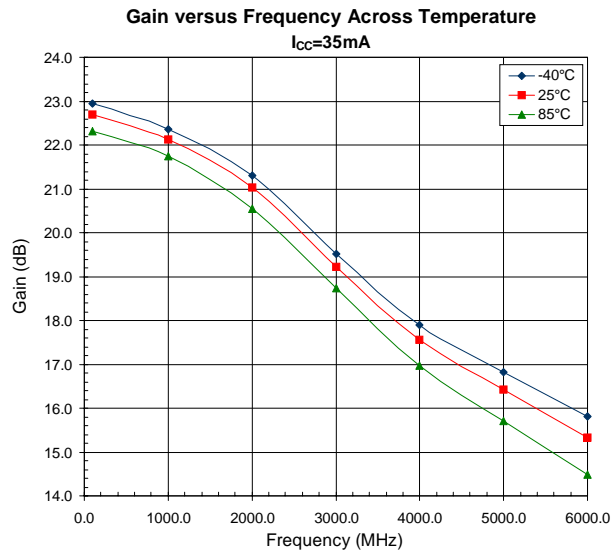

RF2046

Reverse Isolation versus Frequency Across Temperature
 $I_{CC}=35\text{mA}$

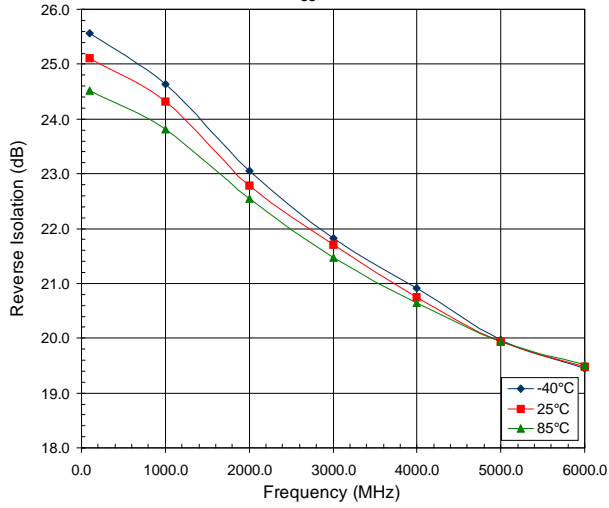

Typical Current versus Voltage
 (At Evaluation Board Connect, $R_{BIAS}=22\ \Omega$)

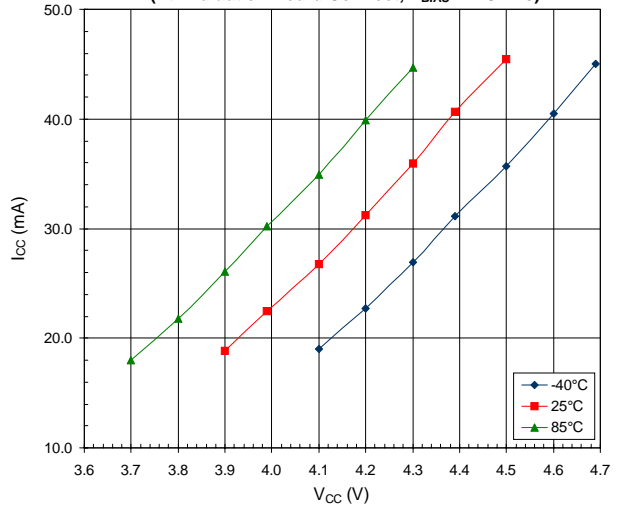

Typical I_{CC} versus V_{PIN}
 (At Pin 3)

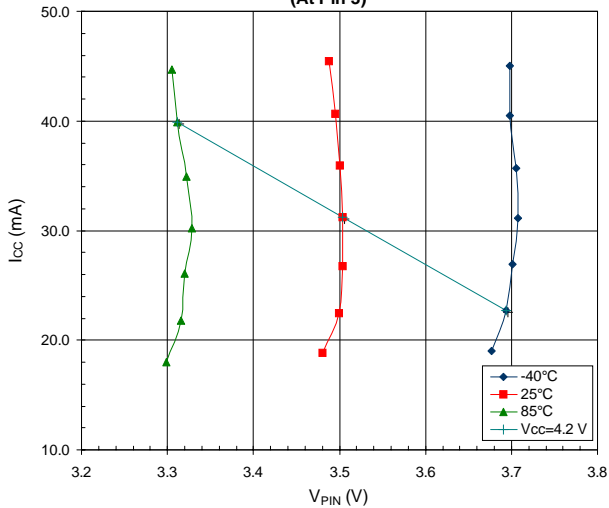

Power Dissipated versus Voltage at Pin 3
 ($T_{AMBIENT}=85^\circ\text{C}$)

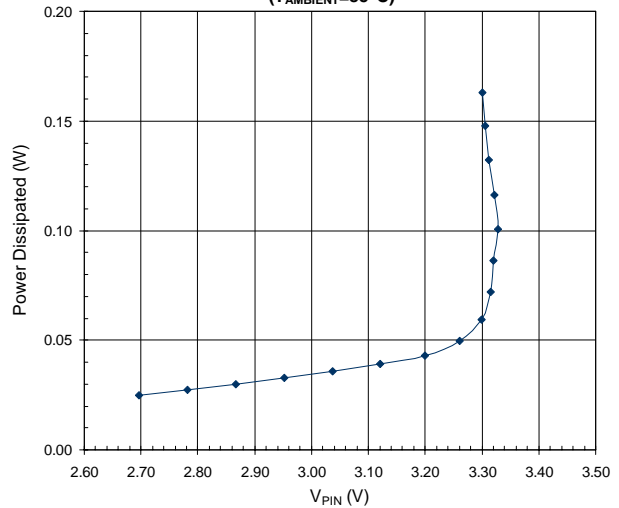

T_{MAX} versus P_{DISS}
 ($T_{AMBIENT}=85^\circ\text{C}$)

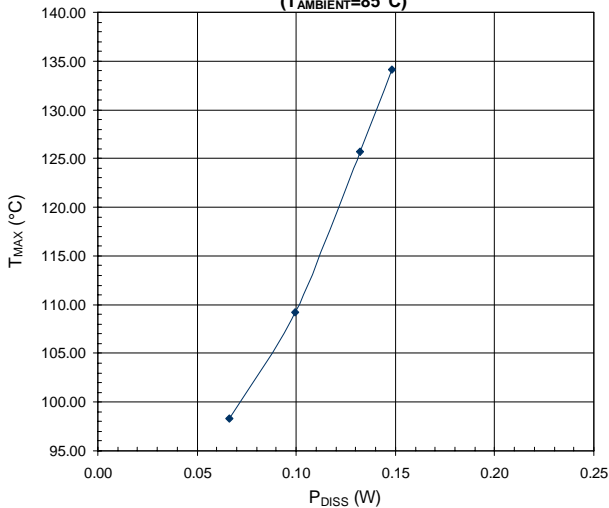

MTTF versus Junction Temperature (Valid for $I_{CC}\leq 35\text{mA}$)
 RFMD HBT2um AlGaAs-2 (60% Confidence Interval)

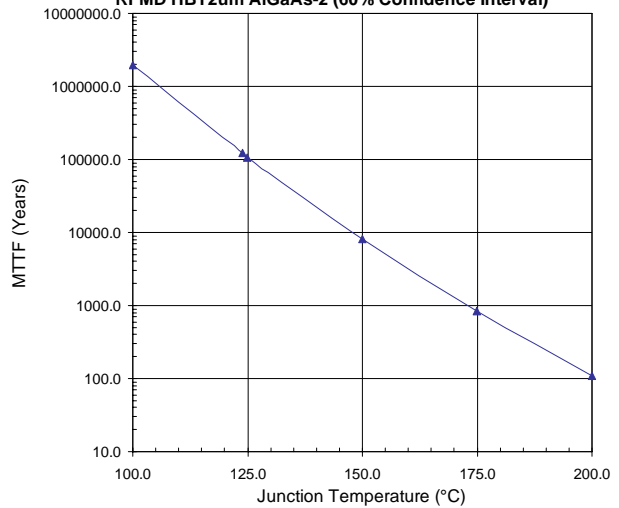

PCB Design Requirements

PCB Surface Finish

The PCB surface finish used for RFMD's qualification process is Electroless Nickel, immersion Gold. Typical thickness is 3μinch to 8μinch Gold over 180μinch Nickel.

PCB Land Pattern Recommendation

PCB land patterns are based on IPC-SM-782 standards when possible. The pad pattern shown has been developed and tested for optimized assembly at RFMD; however, it may require some modifications to address company specific assembly processes. The PCB land pattern has been developed to accommodate lead and package tolerances.

PCB Metal Land Mask Pattern

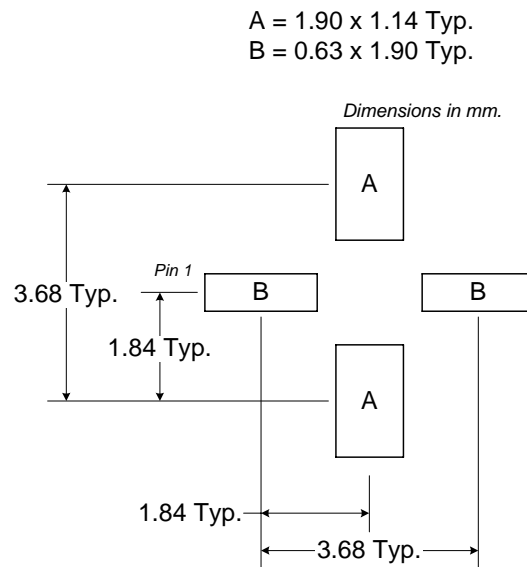

Figure 1. PCB Metal Land Pattern - RF204X (Top View)

PCB Solder Mask Pattern

RF2046

Liquid Photo-Imageable (LPI) solder mask is recommended. The solder mask footprint will match what is shown for the PCB metal land pattern with a 2mil to 3mil expansion to accommodate solder mask registration clearance around all pads. The center-grounding pad shall also have a solder mask clearance. Expansion of the pads to create solder mask clearance can be provided in the master data or requested from the PCB fabrication supplier.

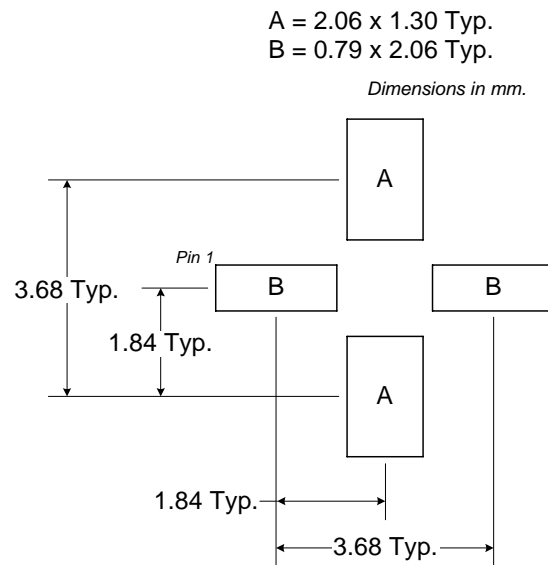

Figure 2. PCB Solder Mask - RF204X (Top View)