

2.5 Gb/s Buried Het 4x100GHz Tunable Laser with Etalon Stabilisation and extended reach option

LC25ET

This laser module employs the Bookham gain coupled SLMQW buried heterostructure DFB laser chip, and has been designed specifically for use in Wavelength Division Multiplexed (WDM) 2.5 Gb/s long distance optical fibre trunk systems.

The device is packaged in a hermetically sealed 14-pin butterfly package incorporating an isolator and locking optics to lock and stabilise wavelength and power of the laser over life.

The module is tunable by means of the internal thermo-electric cooler over four adjacent 100 GHz ITU WDM channels.

The device is available with a number of power options and wavelength schemes, which are customizable to individual customer specification. The internal etalon wavelength stabilisation and low chirp performance makes this product compliant with 50GHz optical channel spacing.

Features:

- 2.5 Gb/s Operation
- Tunable over four separate channels at 100 GHz channel spacing
- Integrated wavelength locking optics
- Entire C band ITU wavelengths available (1528 to 1563 nm)
- Narrow spectral line-width
- Hermetically sealed 14-pin butterfly package with optical isolator
- Internal TEC with precision NTC thermistor
- Extended reach performance up to 360 km with low dispersion penalty
- 50GHz optical channel spacing compliant for interlay or future upgrade
- RoHS compliant 

Applications:

- Optical Service Channel (OSC) applications in DWDM transmission systems using optical amplifiers.

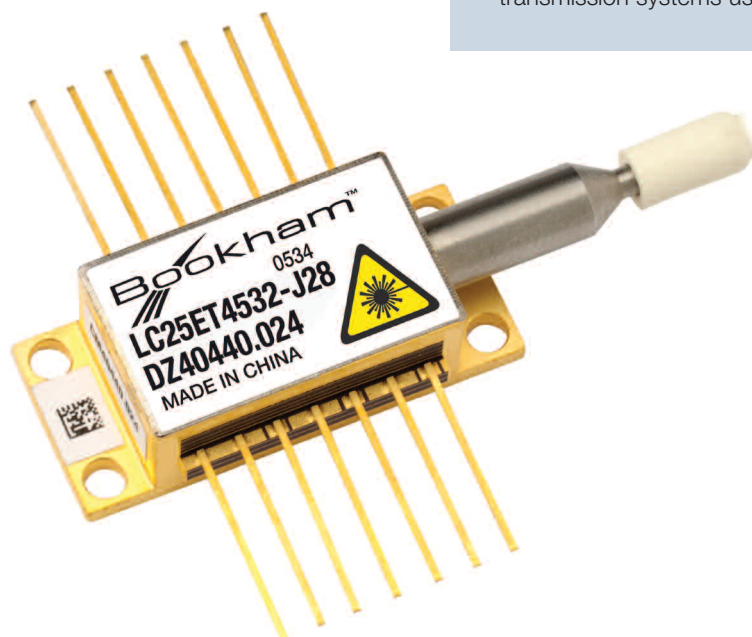

Parameters

Parameter	Conditions	Min	Typ	Max	Unit
Threshold current (I_{th})			10	22	mA
Slope efficiency	2 mW	0.04		0.09	mW/mA
	3 mW	0.06		0.13	mW/mA
	4 mW	0.08		0.17	mW/mA
	High Power [1]	0.143		0.43	mW/mA
RF input reflection coef (S_{11})	[2]			-10	dB
Forward voltage			1.3	1.8	V
Peak wavelength (λ_p)	[3]	1527		1563	nm
Dispersion penalty	[4]			2	dB
Time averaged spectral line width	-20 dB		0.4	0.6	nm
Side-mode suppression		34	40		dB
Optical rise/fall time	[5]			125	ps
Monitor photo currents		40	250	360	μ A
Monitor dark current				50	nA
Thermistor resistance		4.07		20.7	k Ω
Heatpump current	$\Delta T = 64^\circ\text{C}$			1000	mA
Heatpump voltage	$\Delta T = 64^\circ\text{C}$			2.4	V
Change of λ with laser temp.	8 to 50°C		0.09		nm/ $^\circ\text{C}$
Optical spectral window	Over life & temperature including chirp [6]	-9		+9	GHz

[1] The high power version provides 10 mW peak output power for 175 km applications and 7 mW peak output power for 360 km applications.

[2] 50 Ω measurement system, f = dc - 3 GHz.

[3] Submount temperature between 0°C & 40°C start of life to achieve required λ_p .

[4] Dispersion penalty is compliant to a link length of 175 km or 360 km using an extinction ratio of 10dB. Fibre dispersion characteristics are derived from the following equation:

$$D(\lambda) = \frac{So}{4} \left(\lambda - \frac{\lambda_0^4}{\lambda^3} \right) ps / (nm.km)$$

where $So = 0.092$ ps/(nm² km) and $\lambda_0 = 1302$ nm.

[5] Measurements determined from 20 - 80% Pk - Pk.

[6] For more information on wavelength control and drift over life refer to application note DR1670.

Absolute Maximum Ratings

Parameter	Min	Max	Unit
Case operating temperature	0	70	°C
Laser submount operating temperature	8	50	°C
Storage temperature	-40	85	°C
Laser current above I_{th}		100	mA
Laser reverse voltage		1.0	V
Laser reverse current		10	µA
Monitor diode bias		-10	V
Heat pump current		1	A
Heat pump voltage		2.4	V
Fibre bend radius	30		mm

Reliability/Quality

Meets Qualification requirements of Telcordia / Bellcore GR468-Core for central office environment.

Operating reliability <500 FITs¹ in 15 years.

1 - Assumes laser die submount is held within the range 8°C to 50°C by the internal thermoelectric cooler and the product is deployed in equal quantities on each of the four channels with a mean forward current of 35 mA. End of life limits based on 10 mA increase in I_{th} and 25% change in laser efficiency. FIT rate data for other end of life criteria, including minimum extinction ratio requirements, are available on request.

Outline Drawing

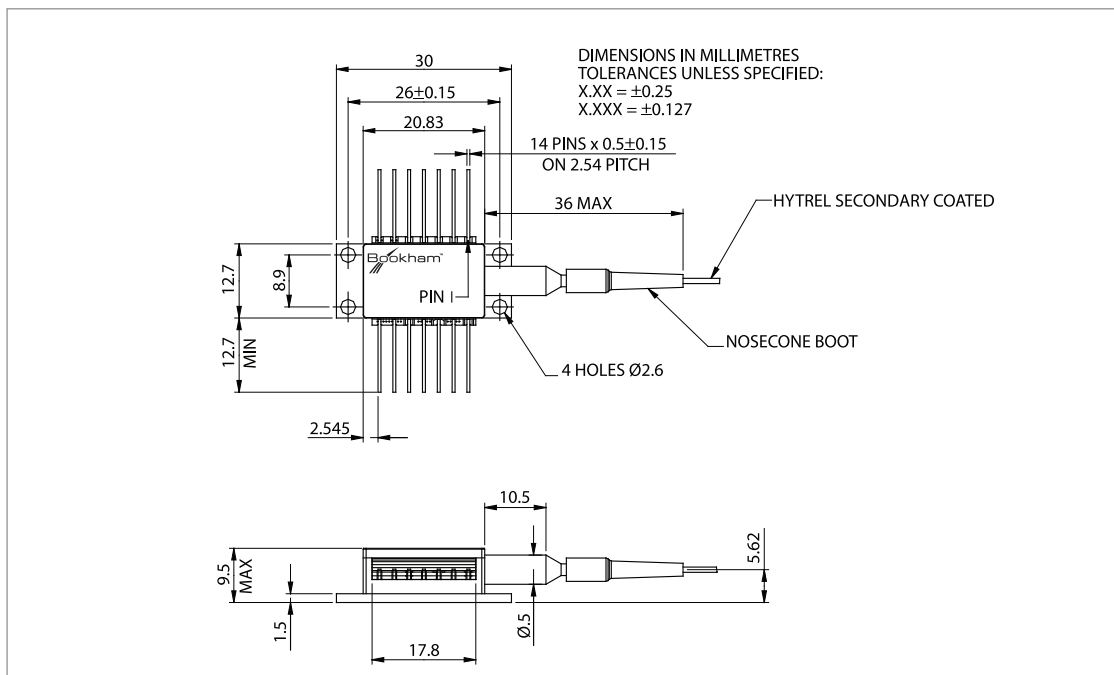

Figure 1: Outline Drawing.

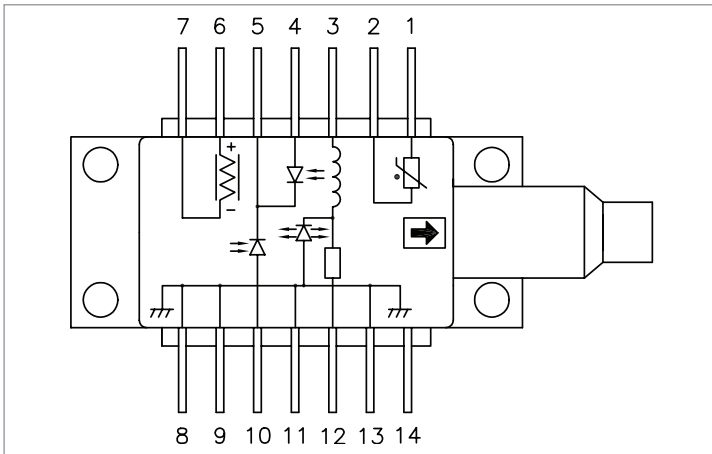

Figure 2: Schematic Diagram.

Connections

Pin #	Function	Pin #	Function
1	Thermistor	8	Case ground
2	Thermistor	9	Case ground
3	Laser DC bias (-)	10	Monitor long anode (-)
4	Monitor short anode (-)	11	Laser case ground
5	Monitor cathode (+)	12	Laser modulation (-)
6	TEC (+)	13	Laser case ground
7	TEC (-)	14	N/C

Instructions for use – LC25ET

Pin 1 and Pin 2 Thermistor

The thermistor is used in a control loop in conjunction with the thermo-electric cooler to maintain the laser submount temperature at the required value for wavelength. Operating current should be less than 100 μ A to prevent self-heating errors.

Pin 3 Laser DC bias (-)

Laser bias current (negative with respect to package ground) is applied via this pin which forms one side of the bias-T connection to the laser cathode.

Pin 4 +10 Monitor anodes, Pin 5 Monitor cathode

Monitor diodes are arranged in the package such that they give an equal monitor current when the laser wavelength is matched to the ITU grid. A reverse bias must be applied equally across each of the monitors, this is commonly achieved by applying 10 V to Pin 5.

Pin 6 TEC (+), Pin 7 TEC (-)

Applying a positive voltage on pin 6 with respect to pin 7 will cause the internal submount to be cooled relative to the case temperature. Reversing the polarity will raise the submount temperature relative to the case. The TEC supply should be capable of delivering up to 1.0 A at 2.4 V.

Pin 8, 9, 11, 13 Case ground

These pins must be grounded in all applications.

Pin 12 Laser modulation (-)

The data input (modulation current) is applied via this pin which is a nominal 25 Ohm impedance coplanar line. For 10mW applications the end of life modulation current is 90mA maximum. For all other applications 60mA maximum modulation current should be provisioned.

Pin 14 N/C

This pin is not connected. It should be grounded if possible.

Ordering Information

LC25ET [Wavelength]	[Power Option]	[Reach]	[Connector]
****	E = 2 mWpk C = 3 mWpk A = 4 mWpk B = High power	A = 175 km - B = 360 km -	J28 = SC/PC J34 = FC/PC J57 = LC J59 = MU

Fibre Length 1130 to 1190 mm.
Other connector types are available on request.

**** = Last four digits of first channel / shortest wavelength
E.g. LC25ET4532CA-J28 has the following four channels:

- 1545.32 nm
- 1546.12 nm
- 1546.92 nm
- 1547.72 nm

The high power option provides 10 mW peak power at 175 km or 7 mW peak power over 360 km.

E.g. **LC25ET4532BA-J28** is a 10 mW 1545.32 nm device with an SC connector for use in a 175 km application.

E.g. **LC25ET4532BB-J28** is a 7 mW 1545.32 nm device with an SC connector for use in a 360 km application.

Lead trimming option

Devices can be supplied with the leads trimmed to a length of 3.81 mm typ.
This option can be specified by adding a 'K' suffix after the reach option.

E.g. **LC25ET4532BAK-J28** is a 10 mW 1545.32 nm device with an SC connector and a lead length of 3.81mm typical, for use in a 175 km application.

RoHS Compliance



Bookham is fully committed to environment protection and sustainable development and has set in place a comprehensive program for removing polluting and hazardous substances from all of its products. The relevant evidence of RoHS compliance is held as part of our controlled documentation for each of our compliant products. RoHS compliance parts are available to order, please refer to the ordering information section for further details.

Contact Information

North America Bookham Worldwide Headquarters

2584 Junction Ave.
San Jose
CA 95134
USA

- Tel: +1 408 919 1500
- Fax: +1 408 919 6083

www.bookham.com
sales@bookham.com

Europe Paignton Office

Brixham Road
Paignton
Devon
TQ4 7BE
United Kingdom

- Tel: +44 (0) 1803 66 2000
- Fax: +44 (0) 1803 66 2801

Asia Shenzhen Office

2 Phoenix Road
Futian Free Trade Zone
Shenzhen 518038
China

- Tel: +86 755 33305888
- Fax: +86 755 33305805
+86 755 33305807

Important Notice

Performance figures, data and any illustrative material provided in this data sheet are typical and must be specifically confirmed in writing by Bookham before they become applicable to any particular order or contract. In accordance with the Bookham policy of continuous improvement specifications may change without notice. The publication of information in this data sheet does not imply freedom from patent or other protective rights of Bookham or others. Further details are available from any Bookham sales representative.



INVISIBLE LASER RADIATION
DO NOT VIEW DIRECTLY WITH
OPTICAL INSTRUMENTS
CLASS 1M LASER
REFERENCE IEC 60825-1: Edition 1.2

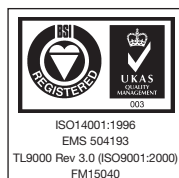

Caution - use of controls or adjustments or performance of procedures other than those specified herein may result in hazardous radiation exposure.