



# DATA SHEET

## ED302T~ED306T

### SUPERFAST RECOVERY RECTIFIERS

VOLTAGE- 200 to 600 Volts CURRENT - 3.0 Amperes

#### FEATURES

- Superfast recovery times-epitaxial construction.
- Low forward voltage, high current capability.
- Exceeds environmental standards of MIL-S-19500/228.
- Hermetically sealed.
- Low leakage.
- High surge capability.
- Plastic package has Underwriters Laboratories Flammability Classification 94V-O utilizing Flame Retardant Epoxy Molding Compound.

#### MECHANICAL DATA

Case: Molded plastic, TO-251AB  
 Terminals: Axial leads, solderable to MIL-STD-202, Method 208  
 Polarity: As marking  
 Weight: 0.015 ounces, 0.4grams.

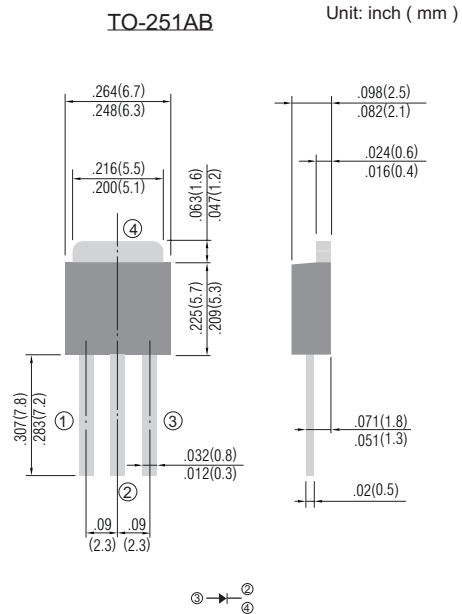

#### MAXIMUM RATINGS AND ELECTRICAL CHARACTERISTICS

Ratings at 25°C ambient temperature unless otherwise specified.  
 Resistive or inductive load, 60Hz.

	ED302T	ED303T	ED304T	ED306T	UNIT
Maximum Recurrent Peak Reverse Voltage	200	300	400	600	V
Maximum RMS Voltage	140	210	280	420	V
Maximum DC Blocking Voltage	200	300	400	600	V
Maximum Average Forward Current .375"(9.5mm) lead length at T <sub>A</sub> =75°C	3.0				A
Peak Forward Surge Current, IFM (surge):8.3ms single half sine-wave superimposed on rated load(JEDEC method)	75				A
Maximum Forward Voltage at 3.0A DC	0.95	1.25	1.70		V
Maximum DC Reverse Current at Rated DC Blocking Voltage	5.0				µA
Maximum DC Reverse Current at Rated DC Blocking Voltage T <sub>A</sub> =125°C	300				µA
Maximum Reverse Recovery Time(Note 1)	35.0				ns
Typical Junction capacitance (Note 2)	45				pF
Typical Junction Resistance(Note 3) RθJA	25				°C/ W
Operating and Storage Temperature Range T <sub>J</sub>	-55 to +150				°C

NOTES:

1. Thermal Resistance Junction to Ambient .



**RATING AND CHARACTERISTIC CURVES**

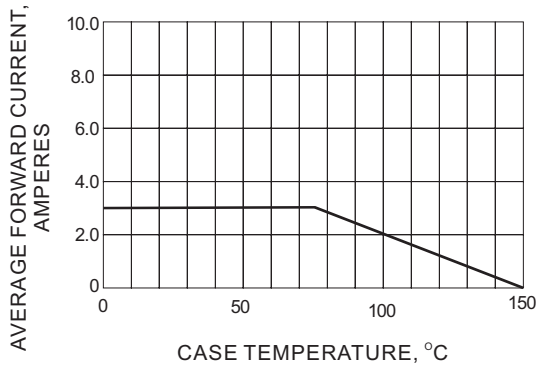

**Fig.1-FORWARD CURRENT DERATING CURVE**

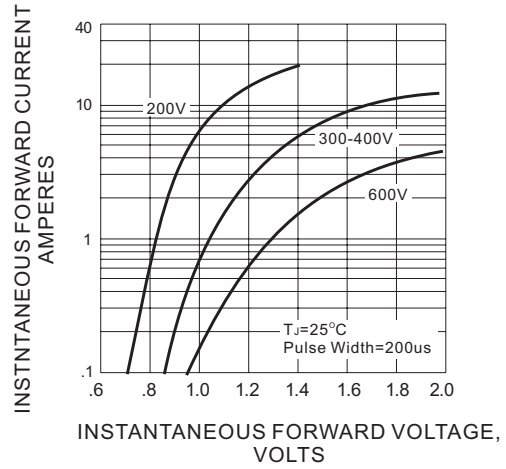

**Fig.2-TYPICAL INSTANTANEOUS FORWARD CHARACTERISTIC**

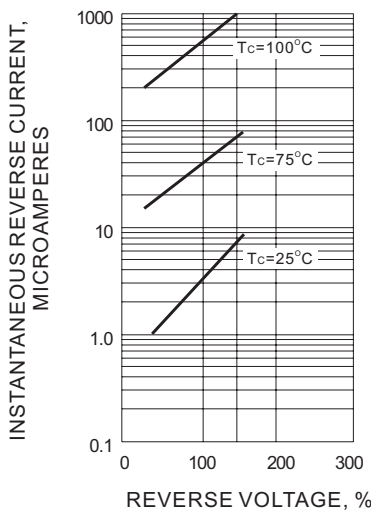

**Fig.3-TYPICAL REVERSE CHARACTERISTICS**

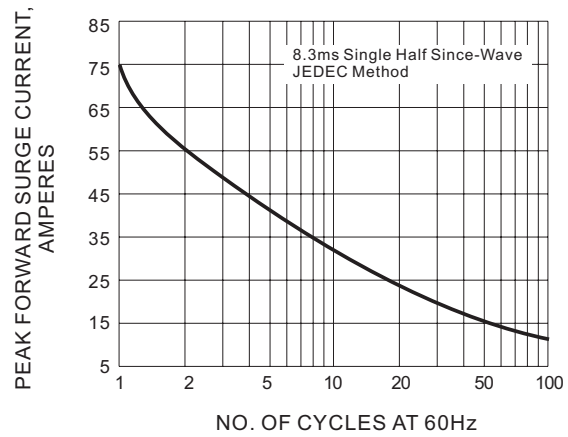

**Fig.4-MAXIMUM NON-REPETITIVE SURGE CURRENT**

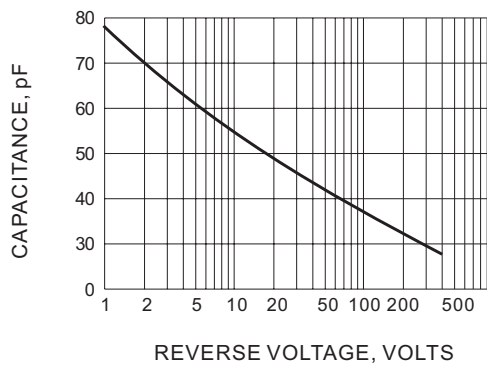

**Fig.5-TYPICAL JUNCTION CAPACITANCE**