

	AK4370
24-Bit 2ch DAC with HP-AMP & Output Mixer	

GENERAL DESCRIPTION

The AK4370 is a 24-bit DAC with headphone amplifier. The AK4370 features an analog mixing circuit that allows easy interfacing in mobile phone and portable communication designs. The integrated headphone amplifier features “pop-noise free” power-on/off, a mute control, and it delivers 40mW of power into 16Ω. The AK4370 is packaged in a 24-pin QFN (4mm×4mm) package, ideal for portable applications.

FEATURE

- Multi-bit $\Delta\Sigma$ DAC**
- Sampling Rate**
 - 8kHz ~ 48kHz
- On chip perfect filtering 8 times FIR interpolator**
 - Passband: 20kHz
 - Passband Ripple: ± 0.02 dB
 - Stopband Attenuation: 54dB
- Digital De-emphasis Filter: 32kHz, 44.1kHz and 48kHz**
- System Clock**
 - 256fs/384fs/512fs/768fs/1024fs
 - Input Level: AC Couple Input Available
- Audio I/F Format: MSB First, 2's Complement**
 - I²S, 24bit MSB justified, 24bit/20bit/16bit LSB justified
 - Master/Slave Mode
- Digital Mixing: LR, LL, RR, (L+R)/2**
- Bass Boost Function**
- Digital ATT**
- Analog Mixing Circuit: 4 Inputs (Single-ended or Full-differential)**
- Stereo Lineout**
 - S/N: 90dB@3.3V
 - Output Volume: +6 to -24dB (or 0 to -30dB), 2dB step
- Headphone Amplifier**
 - Output Power: 40mW x 2ch @16Ω, 3.3V
 - S/N: 92dB@3.3V
 - Pop Noise Free at Power-ON/OFF and Mute
 - Output Volume: 0 ~ -63dB & +12/+6/0 dB Gain
1.5dB step (0 ~ -30dB), 3dB step (-30 ~ -63dB)
- μ P Interface: 3-wire/I²C**
- Power Supply: 1.6V ~ 3.6V**
- Power Supply Current: 3.8mA @1.8V (6.8mW, DAC+HP, No output)**
- Ta: -30 ~ 85°C**
- Small Package: 24pin QFN (4mm x 4mm, 0.5mm pitch)**
- Register Compatible with AK4368**

■ Block Diagram

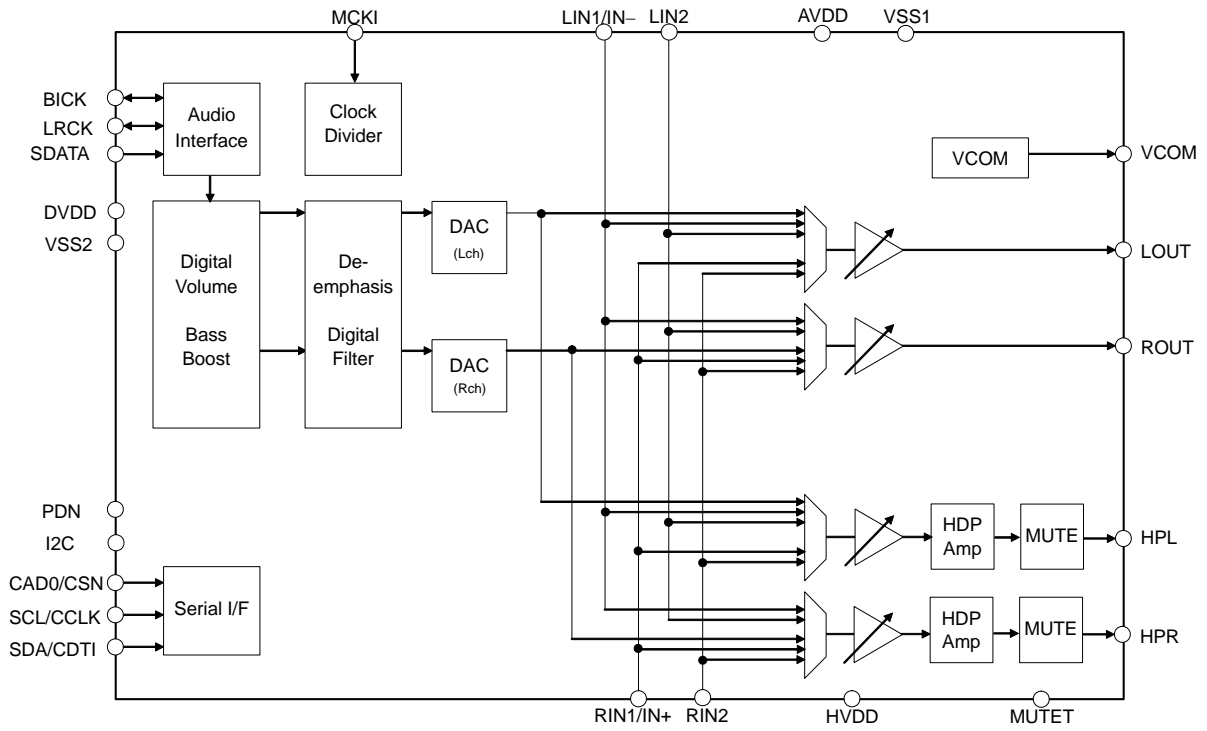

Figure 1. Block Diagram

■ Ordering Information

AK4370VN
AKD4370

-30 ~ +85°C 24pin QFN (0.5mm pitch)
Evaluation board for AK4370

■ Pin Layout

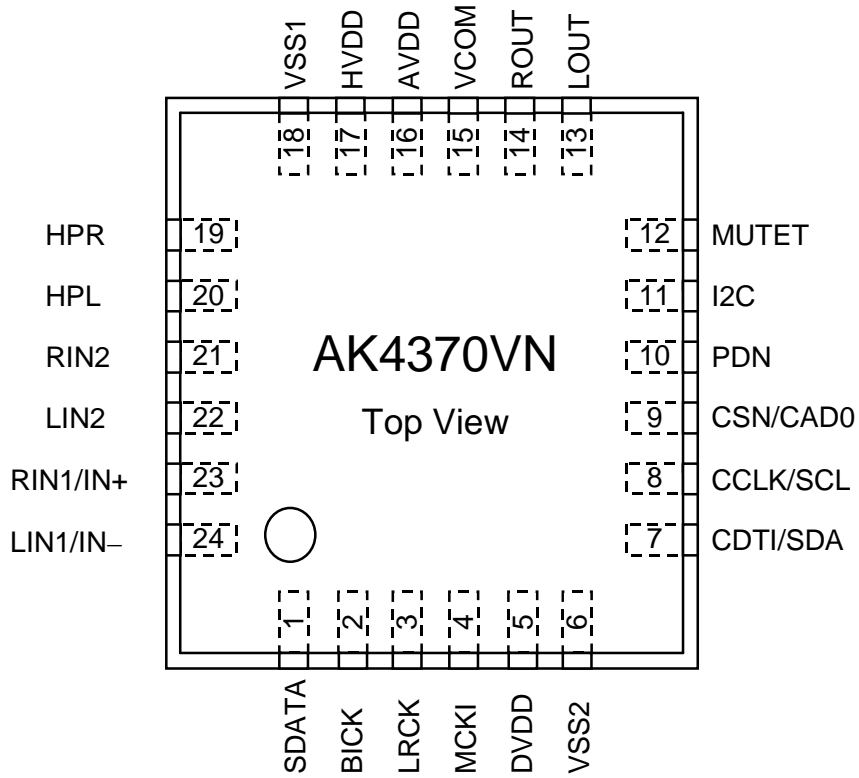

■ Comparison with AK4368

1 Function

Function	AK4368	AK4370
Analog Mixing	1-Stereo + 1-Mono Single-ended Input	2-Stereo Single-ended Input or Full-differential Input
MCKI at EXT Mode	256fs/512fs/1024fs, 12.288MHz(max)	256fs/384fs/512fs/768fs/1024fs, 24.576MHz(max)
HP-Amp Output Volume	No	0 to -63dB & +12/+6/0dB 1.5dB step (0 to -30dB) 3dB step (-30 to -63dB)
HP-Amp Hi-Z Setting	No	Yes
PLL	Yes	No
3D Enhancement	Yes	No
ALC	Yes	No
Package	41BGA (4mm x 4mm)	24QFN (4mm x 4mm)

2 Register (difference from AK4368)

Addr	Register Name	D7	D6	D5	D4	D3	D2	D1	D0
00H	Power Management	0	PMPLL	PMLO	MUTEN	PMHPR	PMHPL	PMDAC	PMVCM
01H	Clock Control 0	FS3	FS2	FS1	FS0	PLL3	PLL2	PLL1	PLL0
02H	Clock Control 1	0	0	M/S	MCKAC	BF	PS0	PS1	MCKO
03H	Mode Control 0	0	MONO1	MONO0	BCKP	LRP	DIF2	DIF1	DIF0
04H	Mode Control 1	ATS	DATC	LMUTE	SMUTE	BST1	BST0	DEM1	DEM0
05H	DAC Lch ATT	ATTL7	ATTL6	ATTL5	ATTL4	ATTL3	ATTL2	ATTL1	ATTL0
06H	DAC Rch ATT	ATTR7	ATTR6	ATTR5	ATTR4	ATTR3	ATTR2	ATTR1	ATTR0
07H	Headphone Out Select 0	HPG1	HPG0	LIN2HR	LIN2HL	RIN1HR	LIN1HL	DARHR	DALHL
08H	Lineout Select 0	0	LOG	LIN2R	LIN2L	RIN1R	LIN1L	DARR	DALL
09H	Lineout ATT	0	0	0	0	ATTS3	ATTS2	ATTS1	ATTS0
0AH	Reserved	REF7	REF6	REF5	REF4	REF3	REF2	REF1	REF0
0BH	Reserved	0	0	ALC	ROTM1	ROTM0	LMAT1	LMAT0	RATF
0CH	Reserved	0	0	0	0	DP1	DP0	3D1	3D0
0DH	Headphone Out Select 1	0	0	0	0	RIN2HR	RIN2HL	LIN1HR	RIN1HL
0EH	Headphone ATT	0	HPZ	HMUTE	ATTH4	ATTH3	ATTH2	ATTH1	ATTH0
0FH	Lineout Select 1	0	0	0	0	RIN2R	RIN2L	LIN1R	RIN1L
10H	Mono Mixing	0	0	0	0	L2M	L2HM	L1M	L1HM
11H	Differential Select	0	0	0	0	0	0	LDIFH	LDIF
12H	Reserved	0	0	0	0	0	0	0	0
13H	Reserved	0	0	0	1	0	0	0	0

These bits are added in the AK4370
 These bits are deleted in the AK4370

PIN/FUNCTION			
No.	Pin Name	I/O	Function
1	SDATA	I	Audio Serial Data Input Pin
2	BICK	I/O	Audio Serial Data Clock Pin
3	LRCK	I/O	Input / Output Channel Clock Pin
4	MCKI	I	External Master Clock Input Pin
5	DVDD	-	Digital Power Supply Pin, 1.6 ~ 3.6V
6	VSS2	-	Ground 2 Pin. Connected to VSS1.
7	SDA	I/O	Control Data Input/Output Pin (I2C mode : I2C pin = "H")
	CDTI	I	Control Data Input Pin (3-wire serial mode : I2C pin = "L")
8	SCL	I	Control Data Clock Pin (I2C mode : I2C pin = "H")
	CCLK	I	Control Data Clock Pin (3-wire serial mode : I2C pin = "L")
9	CAD0	I	Chip Address 0 Select Pin (I2C mode : I2C pin = "H")
	CSN	I	Chip Select Pin (3-wire serial mode : I2C pin = "L")
10	PDN	I	Power-down & Reset When "L", the AK4370 is in power-down mode and is held in reset. The AK4370 should always be reset upon power-up.
11	I2C	I	Control Mode Select Pin "H": I ² C Bus, "L": 3-wire Serial
12	MUTET	O	Mute Time Constant Control pin Connected to VSS1 pin with a capacitor for mute time constant.
13	LOUT	O	Lch Stereo Line Output Pin
14	ROUT	O	Rch Stereo Line Output Pin
15	VCOM	O	Common Voltage Output Pin Normally connected to VSS1 pin with a 2.2 μ F electrolytic capacitor.
16	AVDD	-	Analog Power Supply Pin, 1.6 ~ 3.6V
17	HVDD	-	Power Supply Pin for Headphone Amp, 1.6 ~ 3.6V
18	VSS1	-	Ground 1 Pin
19	HPR	O	Rch Headphone Amp Output
20	HPL	O	Lch Headphone Amp Output
21	RIN2	I	Rch Analog Input 2 Pin
22	LIN2	I	Lch Analog Input 2 Pin
23	RIN1	I	Rch Analog Input 1 Pin (LDIF bit = "0" : Single-ended Input)
	IN+	I	Positive Line Input Pin (LDIF bit = "1" : Full-differential Input)
24	LIN1	I	Rch Analog Input 1 Pin (LDIF bit = "0" : Single-ended Input)
	IN-	I	Negative Line Input Pin (LDIF bit = "1" : Full-differential Input)

Note 1. All digital input pins (I2C, SDA/CDTI, SCL/CCLK, CAD0/CSN, SDATA, LRCK, BICK, MCKI, PDN) must not be left floating. MCKI pin can be left floating only when PDN pin = "L".

■ Handling of Unused Pin

The unused I/O pins should be processed appropriately as below.

Classification	Pin Name	Setting
Analog	LOUT, ROUT, MUTET, HPL, HPR, LIN2, RIN2, RIN1/IN+, LIN1/IN-	These pins should be open.
Digital	MCKI	This pin should be connected to VSS2.

ABSOLUTE MAXIMUM RATING

(VSS1, VSS2=0V; Note 2, Note 3)

Parameter	Symbol	min	max	Units	
Power Supplies	Analog	AVDD	-0.3	4.6	V
	Digital	DVDD	-0.3	4.6	V
	HP-Amp	HVDD	-0.3	4.6	V
Input Current (any pins except for supplies)	IIN	-	±10	mA	
Analog Input Voltage (Note 4)	VINA	-0.3	(AVDD+0.3) or 4.6	V	
Digital Input Voltage (Note 5)	VIND	-0.3	(DVDD+0.3) or 4.6	V	
Ambient Temperature	Ta	-30	85	°C	
Storage Temperature	Tstg	-65	150	°C	

Note 2. All voltages with respect to ground.

Note 3. VSS1 and VSS2 must be connected to the same analog ground plane.

Note 4. LIN1/IN-, RIN1/IN+, LIN2 and RIN2 pins. Max is smaller value between (AVDD+0.3)V and 4.6V.

Note 5. SDA/CDTI, SCL/CCLK, CAD0/CSN, SDATA, LRCK, BICK, MCKI, PDN and I2C pins. Max is smaller value between (DVDD+0.3)V and 4.6V.

WARNING: Operation at or beyond these limits may result in permanent damage to the device.
Normal operation is not guaranteed at these extremes.

RECOMMEND OPERATING CONDITIONS

(VSS1, VSS2=0V; Note 2)

Parameter	Symbol	min	typ	max	Units	
Power Supplies (Note 6)	Analog	AVDD	1.6	2.4	3.6	V
	Digital (Note 7)	DVDD	1.6	2.4	(AVDD+0.2) or 3.6	V
	HP-Amp	HVDD	1.6	2.4	3.6	V
	Difference	AVDD-HVDD	-0.3	0	+0.3	V

Note 2. All voltages with respect to ground.

Note 6. When AVDD and DVDD are supplied separately, AVDD should be powered-up after DVDD rises up to 1.6V or more. When the AK4370 is powered-down, DVDD should be powered-down at the same time or later than AVDD. When AVDD and HVDD are supplied separately, AVDD should be powered-up at the same time or earlier than HVDD. When the AK4370 is powered-down, AVDD should be powered-down at the same time or later than HVDD.

Note 7. Max is smaller value between (AVDD+0.2)V and 3.6V.

* AKM assumes no responsibility for usage beyond the conditions in this datasheet.

ANALOG CHARACTERISTICS

(Ta=25°C; AVDD=DVDD=HVDD=2.4V, VSS1=VSS2=0V; fs=44.1kHz; BOOST OFF; Slave Mode; Signal Frequency =1kHz; Measurement band width=20Hz ~ 20kHz; Headphone-Amp: Load impedance is a serial connection with $R_L=16\Omega$ and $C_L=220\mu F$. (Refer to Figure 38; unless otherwise specified))

Parameter	min	typ	max	Units	
DAC Resolution	-	-	24	bit	
Headphone-Amp: (HPL/HPR pins) (Note 8)					
Analog Output Characteristics					
THD+N	-3dBFS Output, 2.4V, Po=10mW@16Ω	-	-50	-40	dB
	0dBFS Output, 3.3V, Po=40mW@16Ω	-	-20	-	dB
D-Range	-60dBFS Output, A-weighted, 2.4V	82	90	-	dB
	-60dBFS Output, A-weighted, 3.3V	-	92	-	dB
S/N	A-weighted, 2.4V	82	90	-	dB
	A-weighted, 3.3V	-	92	-	dB
Interchannel Isolation	60	80	-	dB	
DC Accuracy					
Interchannel Gain Mismatch	-	0.3	0.8	dB	
Gain Drift	-	200	-	ppm/°C	
Load Resistance (Note 9)	16	-	-	Ω	
Load Capacitance	-	-	300	pF	
Output Voltage	-3dBFS Output (Note 10)	1.04	1.16	1.28	Vpp
	0dBFS Output, 3.3V, Po=40mW@16Ω	-	0.8	-	Vrms
Output Volume: (HPL/HPR pins)					
Step Size (HPG1-0 bits = "00")	0 ~ -30dB	0.1	1.5	2.9	dB
	-30 ~ -63dB	0.1	3	5.9	dB
Gain Control Range (HPG1-0 bits = "00")	Max (ATT4-0 bits = "00H")	-	0	-	dB
	Min (ATT4-0 bits = "1FH")	-	-63	-	dB
Stereo Line Output: (LOUT/ROUT pins, RL=10kΩ) (Note 11)					
Analog Output Characteristics:					
THD+N (0dBFS Output)	-	-60	-50	dB	
S/N	A-weighted, 2.4V	80	87	-	dB
	A-weighted, 3.3V	-	90	-	dB
DC Accuracy					
Gain Drift	-	200	-	ppm/°C	
Load Resistance (Note 9)	10	-	-	kΩ	
Load Capacitance	-	-	25	pF	
Output Voltage (0dBFS Output) (Note 12)	1.32	1.47	1.61	Vpp	
Output Volume: (LOUT/ROUT pins)					
Step Size	1	2	3	dB	
Gain Control Range (LOG1-0 bit = "0")	Max (ATTS3-0 bits = "FH")	-	0	-	dB
	Min (ATTS3-0 bits = "0H")	-	-30	-	dB

Note 8. DALHL=DARHR bits = "1"

LIN1HL=RIN1HL=LIN2HL=RIN2HL=LIN1HR=RIN1HR=LIN2HR=RIN2HR bits = "0".

Note 9. AC load.

Note 10. Output voltage is proportional to AVDD voltage. $V_{out} = 0.48 \times AVDD(\text{typ})@-3\text{dBFS}$.

Note 11. DALL=DARR bits = "1"

LIN1L=RIN1L=LIN2L=RIN2L=LIN1R=RIN1R=LIN2R=RIN2R bits = "0"

Note 12. Output voltage is proportional to AVDD voltage. $V_{out} = 0.61 \times AVDD(\text{typ})@0\text{dBFS}$.

Parameter	min	typ	max	Units
LINEIN: (LIN1/RIN1/LIN2/RIN2 pins)				
Analog Input Characteristics				
Input Resistance (Refer to Figure 21, Figure 22)				
LIN1 pin LIN1HL=LIN1HR=LIN1L=LIN1R bits = "1"	14	25	-	kΩ
LIN1HL bit = "1", LIN1HR=LIN1L=LIN1R bits = "0"	-	100	-	kΩ
LIN1HR bit = "1", LIN1HL=LIN1L=LIN1R bits = "0"	-	100	-	kΩ
LIN1L bit = "1", LIN1HL=LIN1HR=LIN1R bits = "0"	-	100	-	kΩ
LIN1R bit = "1", LIN1HL=LIN1HR=LIN1L bits = "0"	-	100	-	kΩ
RIN1 pin RIN1HL=RIN1HR=RIN1L=RIN1R bits = "1"	14	25	-	kΩ
RIN1HL bit = "1", RIN1HR=RIN1L=RIN1R bits = "0"	-	100	-	kΩ
RIN1HR bit = "1", RIN1HL=RIN1L=RIN1R bits = "0"	-	100	-	kΩ
RIN1L bit = "1", RIN1HL=RIN1HR=RIN1R bits = "0"	-	100	-	kΩ
RIN1R bit = "1", RIN1HL=RIN1HR=RIN1L bits = "0"	-	100	-	kΩ
LIN2 pin LIN2HL=LIN2HR=LIN2L=LIN2R= bits = "1"	14	25	-	kΩ
LIN2HL bit = "1", LIN2HR=LIN2L=LIN2R bits = "0"	-	100	-	kΩ
LIN2HR bit = "1", LIN2HL=LIN2L=LIN2R bits = "0"	-	100	-	kΩ
LIN2L bit = "1", LIN2HL=LIN2HR=LIN2R bits = "0"	-	100	-	kΩ
LIN2R bit = "1", LIN2HL=LIN2HR=LIN2L bits = "0"	-	100	-	kΩ
RIN2 pin RIN2HL=RIN2HR=RIN2L=RIN2R bits = "1"	14	25	-	kΩ
RIN2HL bit = "1", RIN2HR=RIN2L=RIN2R bits = "0"	-	100	-	kΩ
RIN2HR bit = "1", RIN2HL=RIN2L=RIN2R bits = "0"	-	100	-	kΩ
RIN2L bit = "1", RIN2HL=RIN2HR=RIN2R bits = "0"	-	100	-	kΩ
RIN2R bit = "1", RIN2HL=RIN2HR=RIN2L bits = "0"	-	100	-	kΩ
Gain				
LIN1/LIN2/RIN1/RIN2 → LOUT/ROUT	-1	0	+1	dB
LIN1/LIN2/RIN1/RIN2 → HPL/HPR	-0.05	+0.95	+1.95	dB
Power Supplies				
Power Supply Current				
Normal Operation (PDN pin = "H") (Note 13)				
AVDD+DVDD	-	3.8	5.5	mA
HVDD	-	1.2	2.5	mA
Power-Down Mode (PDN pin = "L") (Note 14)	-	1	100	μA

Note 13. PMDAC=PMHPL=PMHPR=PMLO bits = "1", MUTEN bit = "1", HP-Amp no output.
 PMDAC=PMHPL=PMHPR= "1", PMLO bit= "0", AVDD+DVDD+HVDD=4.0mA (typ) @2.4V, 3.8mA (typ) @1.8V.

Note 14. All digital input pins are fixed to VSS2.

FILTER CHARACTERISTICS							
(Ta=25°C; AVDD, DVDD, HVDD=1.6 ~ 3.6V; fs=44.1kHz; De-emphasis = "OFF")							
Parameter		Symbol	min	typ	max	Units	
DAC Digital Filter: (Note 15)							
Passband (Note 16)	-0.05dB	PB	0	-	20.0	kHz	
	-6.0dB		-	22.05	-	kHz	
Stopband (Note 16)		SB	24.1	-	-	kHz	
Passband Ripple		PR	-	-	±0.02	dB	
Stopband Attenuation		SA	54	-	-	dB	
Group Delay (Note 17)		GD	-	22	-	1/fs	
Group Delay Distortion		ΔGD	-	0	-	μs	
DAC Digital Filter + Analog Filter: (Note 15, Note 18)							
Frequency Response	0 ~ 20.0kHz	FR	-	±0.5	-	dB	
Analog Filter: (Note 19)							
Frequency Response	0 ~ 20.0kHz	FR	-	±1.0	-	dB	
BOOST Filter: (Note 18, Note 20)							
Frequency Response	MIN	20Hz	FR	-	5.76	-	dB
		100Hz		-	2.92	-	dB
		1kHz		-	0.02	-	dB
	MID	20Hz	FR	-	10.80	-	dB
		100Hz		-	6.84	-	dB
		1kHz		-	0.13	-	dB
	MAX	20Hz	FR	-	16.06	-	dB
		100Hz		-	10.54	-	dB
		1kHz		-	0.37	-	dB

Note 15. BOOST OFF (BST1-0 bit = "00")

Note 16. The passband and stopband frequencies scale with fs (system sampling rate).

For example, PB=0.4535fs(@-0.05dB). SB=0.546fs(@-54dB).

Note 17. This time is from setting the 24-bit data of both channels from the input register to the output of analog signal.

Note 18. DAC → HPL, HPR, LOU, ROUT

Note 19. LIN1/LIN2/RIN1/RIN2 → HPL/HPR/LOU/ROUT

Note 20. These frequency responses scale with fs. If high-level signal is input, the output clips at low frequency.

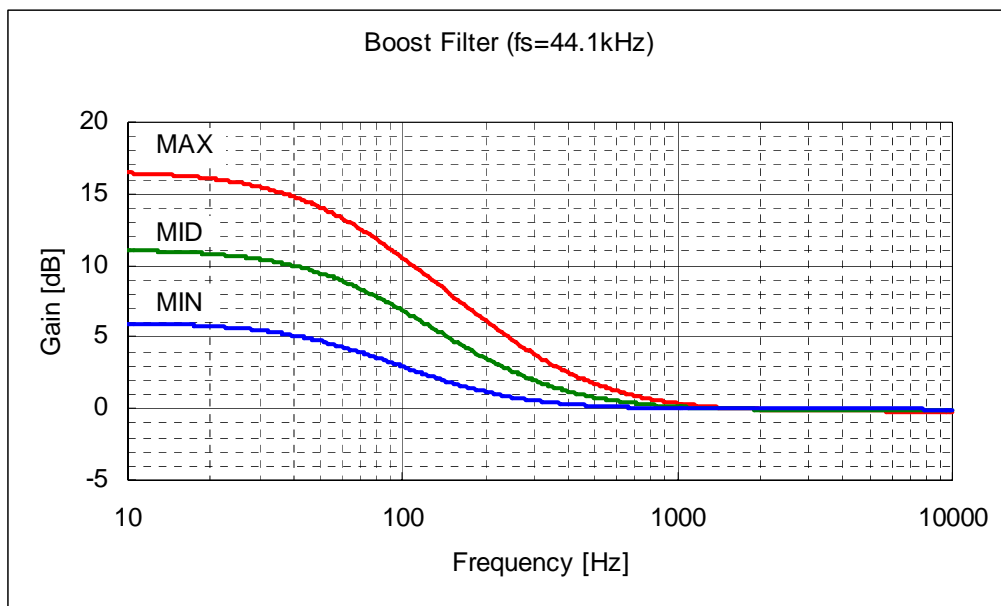

Figure 2. Boost Frequency (fs=44.1kHz)

DC CHARACTERISTICS

(Ta=25°C; AVDD, DVDD, HVDD=1.6 ~ 3.6V)

Parameter		Symbol	min	typ	max	Units
High-Level Input Voltage	2.2V≤DVDD≤3.6V	VIH	70%DVDD	-	-	V
	1.6V≤DVDD<2.2V	VIH	80%DVDD	-	-	V
Low-Level Input Voltage	2.2V≤DVDD≤3.6V	VIL	-	-	30%DVDD	V
	1.6V≤DVDD<2.2V	VIL	-	-	20%DVDD	V
Input Voltage at AC Coupling (Note 21)		VAC	0.4	-	-	Vpp
High-Level Output Voltage	(Iout=-200μA)	VOH	DVDD-0.2	-	-	V
Low-Level Output Voltage	(Except SDA pin: Iout=200μA)	VOL	-	-	0.2	V
	(SDA pin, 2.0V≤DVDD≤3.6V: Iout=3mA)	VOL	-	-	0.4	V
	(SDA pin, 1.6V≤DVDD<2.0V: Iout=3mA)	VOL	-	-	20%DVDD	V
Input Leakage Current		Iin	-	-	±10	μA

Note 21. MCKI is connected to a capacitor. (Refer to Figure 38)

SWITCHING CHARACTERISTICS

(Ta=25°C; AVDD, DVDD, HVDD=1.6 ~ 3.6V; C_L = 20pF; unless otherwise specified)

Parameter	Symbol	min	typ	max	Units
Master Clock Input Timing					
Frequency	fCLK	2.048	-	24.576	MHz
Pulse Width Low (Note 22)	tCLKL	0.4/fCLK	-	-	ns
Pulse Width High (Note 22)	tCLKH	0.4/fCLK	-	-	ns
AC Pulse Width (Note 23)	tACW	20.3	-	-	ns
LRCK Timing					
Frequency	fs	8	44.1	48	kHz
Duty Cycle: Slave Mode	Duty	45	-	55	%
Master Mode	Duty	-	50	-	%
Serial Interface Timing (Note 24)					
Slave Mode (M/S bit = "0"):					
BICK Period (Note 25)	tBCK	312.5 or 1/(64fs)	-	1/(32fs)	ns
BICK Pulse Width Low	tBCKL	100	-	-	ns
Pulse Width High	tBCKH	100	-	-	ns
LRCK Edge to BICK "↑" (Note 26)	tLRB	50	-	-	ns
BICK "↑" to LRCK Edge (Note 26)	tBLR	50	-	-	ns
SDATA Hold Time	tSDH	50	-	-	ns
SDATA Setup Time	tSDS	50	-	-	ns
Master Mode (M/S bit = "1"):					
BICK Frequency (BF bit = "1")	fBCK	-	64fs	-	Hz
(BF bit = "0")	fBCK	-	32fs	-	Hz
BICK Duty	dBCK	-	50	-	%
BICK "↓" to LRCK	tMBLR	-50	-	50	ns
SDATA Hold Time	tSDH	50	-	-	ns
SDATA Setup Time	tSDS	50	-	-	ns
Control Interface Timing (3-wire Serial mode)					
CCLK Period	tCCK	200	-	-	ns
CCLK Pulse Width Low	tCCKL	80	-	-	ns
Pulse Width High	tCCKH	80	-	-	ns
CDTI Setup Time	tCDS	40	-	-	ns
CDTI Hold Time	tCDH	40	-	-	ns
CSN "H" Time	tCSW	150	-	-	ns
CSN "↑" to CCLK "↑"	tCSS	50	-	-	ns
CCLK "↑" to CSN "↑"	tCSH	50	-	-	ns

Note 22. Except AC coupling.

Note 23. Pulse width to ground level when MCKI is connected to a capacitor in series and a resistor is connected to ground. (Refer to Figure 3.)

Note 24. Refer to "Serial Data Interface".

Note 25. Min is longer value between 312.5ns or 1/(64fs) except for PLL Mode, PLL4-0 bits = "EH", "FH".

Note 26. BICK rising edge must not occur at the same time as LRCK edge.

Parameter	Symbol	min	typ	max	Units
Control Interface Timing (I²C Bus mode): (Note 27)					
SCL Clock Frequency	fSCL	-	-	400	kHz
Bus Free Time Between Transmissions	tBUF	1.3	-	-	μs
Start Condition Hold Time (prior to first clock pulse)	tHD:STA	0.6	-	-	μs
Clock Low Time	tLOW	1.3	-	-	μs
Clock High Time	tHIGH	0.6	-	-	μs
Setup Time for Repeated Start Condition	tSU:STA	0.6	-	-	μs
SDA Hold Time from SCL Falling (Note 28)	tHD:DAT	0	-	-	μs
SDA Setup Time from SCL Rising	tSU:DAT	0.1	-	-	μs
Rise Time of Both SDA and SCL Lines	tR	-	-	0.3	μs
Fall Time of Both SDA and SCL Lines	tF	-	-	0.3	μs
Setup Time for Stop Condition	tSU:STO	0.6	-	-	μs
Capacitive Load on Bus	Cb	-	-	400	pF
Pulse Width of Spike Noise Suppressed by Input Filter	tSP	0	-	50	ns
Power-down & Reset Timing					
PDN Pulse Width (Note 29)	tPD	150	-	-	ns

Note 27. I²C is a registered trademark of Philips Semiconductors.

Note 28. Data must be held long enough to bridge the 300ns-transition time of SCL.

Note 29. The AK4370 can be reset by bringing PDN pin = "L" to "H" only upon power up.

■ Timing Diagram

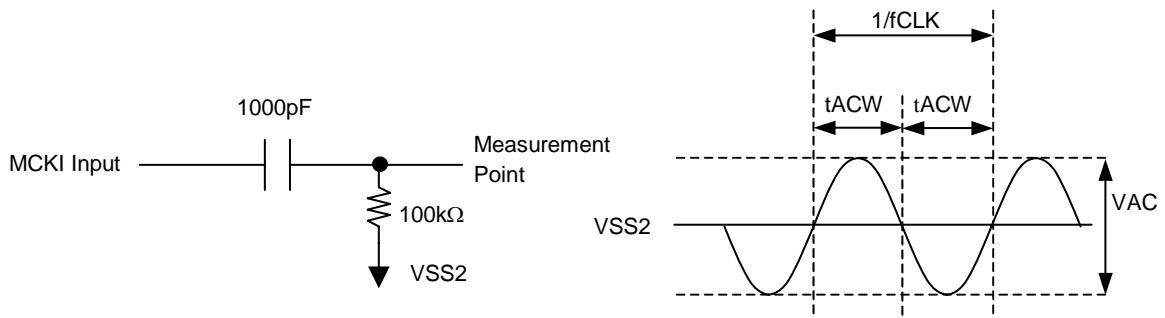

Figure 3. MCKI AC Coupling Timing

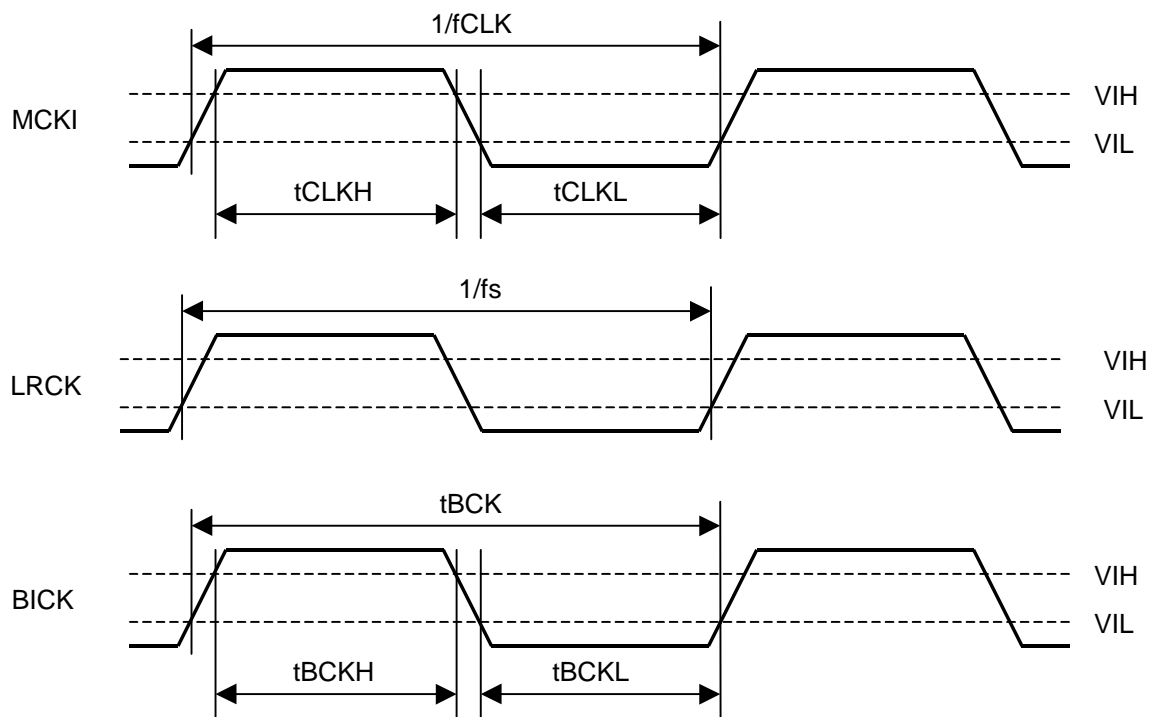

Figure 4. Clock Timing

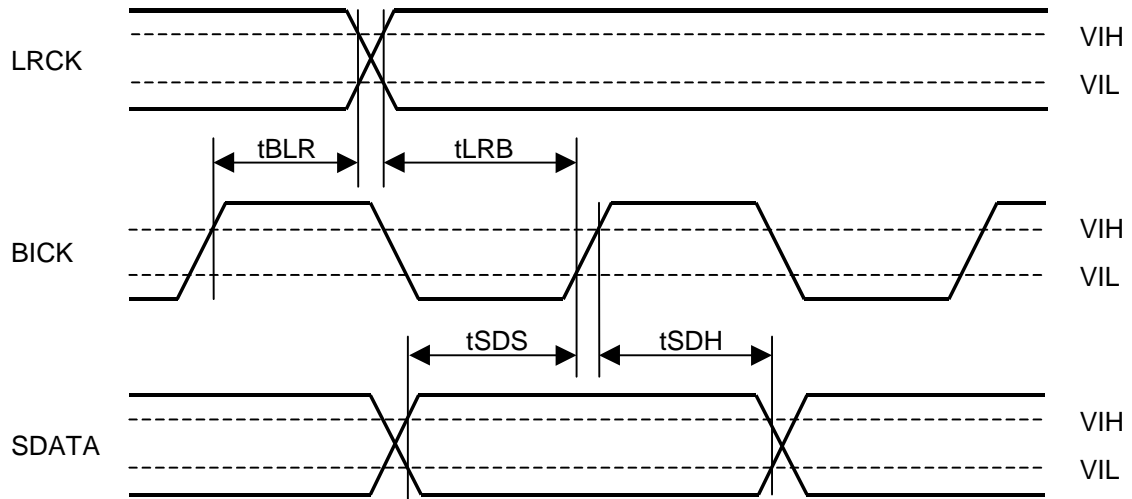

Figure 5. Serial Interface Timing (Slave Mode)

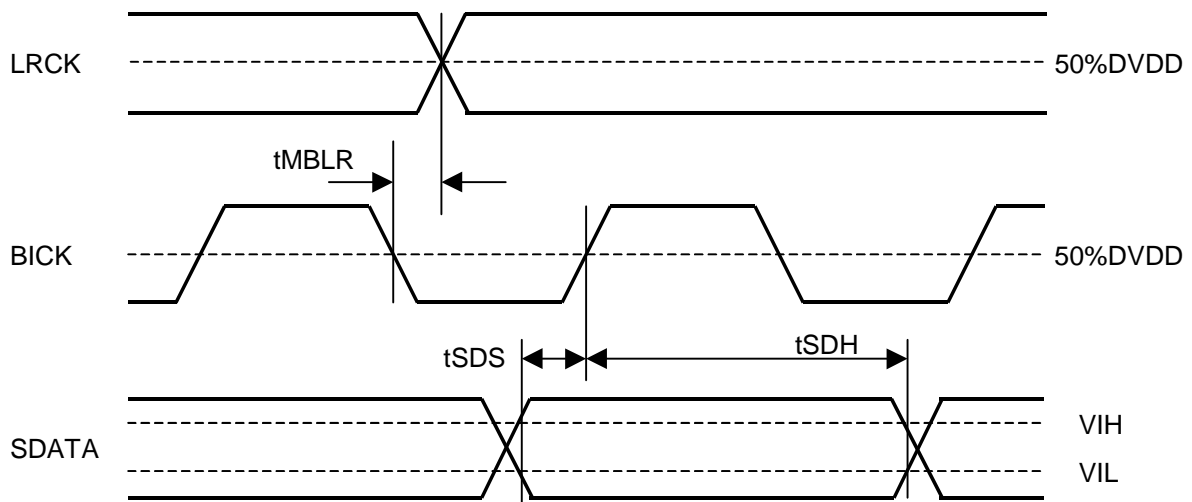

Figure 6. Serial Interface Timing (Master mode)

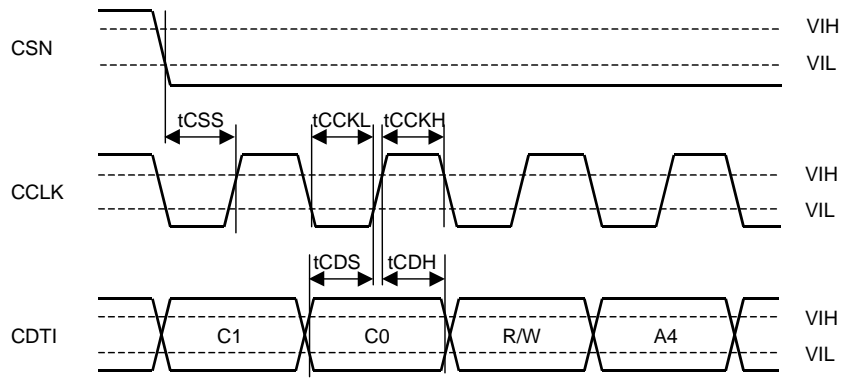

Figure 7. WRITE Command Input Timing

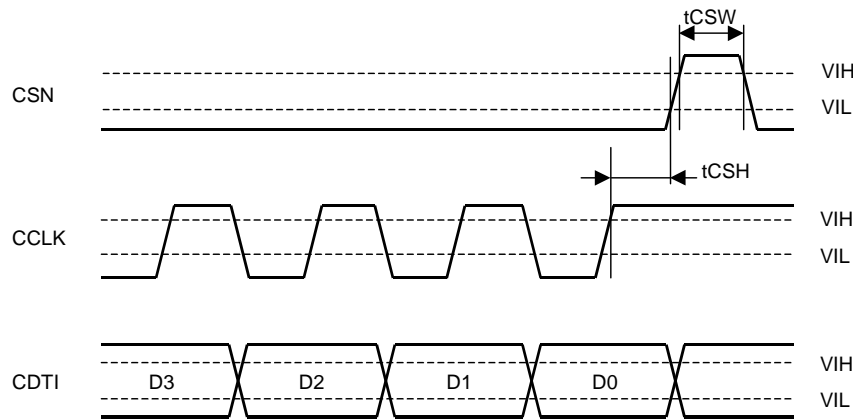

Figure 8. WRITE Data Input Timing

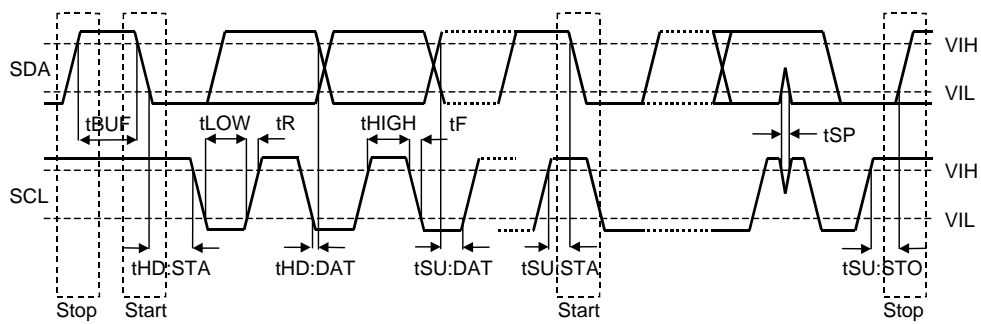

Figure 9. I²C Bus Mode Timing

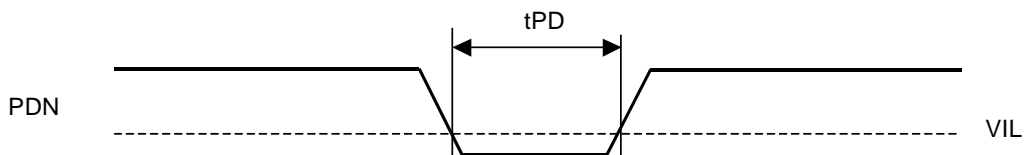

Figure 10. Power-down & Reset Timing

OPERATION OVERVIEW

■ **System Clock**

The AK4370 supports both master and slave modes to interface with external devices. (See Table 1).

The M/S bit selects either master or slave mode. M/S bit = “1” selects master mode and “0” selects slave mode. When the AK4370 is power-down mode (PDN pin = “L”) and exits reset state, the AK4370 is slave mode. After exiting reset state, the AK4370 goes to master mode by changing M/S bit = “1”.

When the AK4370 is used by master mode, LRCK and BICK pins are a floating state until M/S bit becomes “1”. LRCK and BICK pins of the AK4370 should be pulled-down or pulled-up by the resistor (about 100kΩ) externally to avoid the floating state.

M/S bit	Mode	MCKI pin	BICK pin	LRCK pin	Figure
1	Master Mode	Selected by FS3-0 bits	Output (Selected by BF bit)	Output (1fs)	Figure 11
0	Slave Mode	Selected by FS3-0 bits	Input (32fs ~ 64fs)	Input (1fs)	Figure 12

default

Table 1. Clock Mode Setting (x: Don't care)

The frequency of master clock inputted to the MCKI pin can be selected FS3-0 bits. (Refer to Table 2)
 If the sampling frequency is changed during normal operation of the DAC (PMDAC bit = “1”), the change should occur after the input is muted by SMUTE bit = “1”, or the input is set to “0” data.

LRCK and BICK are output from the AK4370 in master mode (Figure 11). The clock input to the MCKI pin should always be present whenever the DAC is in normal operation (PMDAC bit = “1”). If these clocks are not provided, the AK4370 may draw excessive current and will not operate properly because it utilizes these clocks for internal dynamic refresh of registers. If the external clocks are not present, the DAC should be placed in power-down mode (PMDAC bit = “0”).

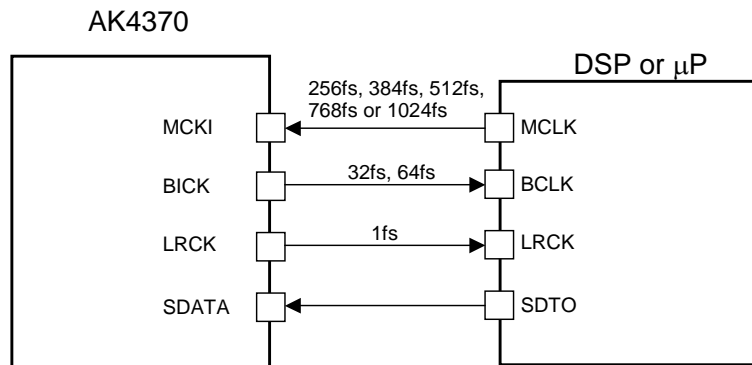

Figure 11. Master Mode

The external clocks required to operate the AK4370 in slave mode are MCKI, LRCK and BICK (Figure 12). The master clock (MCKI) should be synchronized with the sampling clock (LRCK). The phase between these clocks does not matter. All external clocks (MCKI, BICK and LRCK) should always be present whenever the DAC is in normal operation mode (PMDAC bit = "1"). If these clocks are not provided, the AK4370 may draw excessive current and will not operate properly, because it utilizes these clocks for internal dynamic refresh of registers. If the external clocks are not present, the DAC should be placed in power-down mode (PMDAC bit = "0").

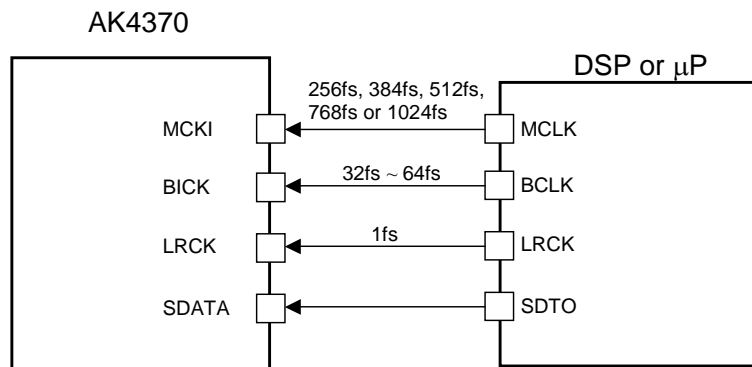

Figure 12. Slave Mode

Mode	FS3	FS2	FS1	FS0	fs	MCKI
0	0	0	0	0	8kHz ~ 48kHz	256fs
1	0	0	0	1	8kHz ~ 48kHz	512fs
2	0	0	1	0	8kHz ~ 24kHz	1024fs
4	0	1	0	0	8kHz ~ 48kHz	256fs
5	0	1	0	1	8kHz ~ 48kHz	512fs
6	0	1	1	0	8kHz ~ 24kHz	1024fs
8	1	0	0	0	8kHz ~ 48kHz	256fs
9	1	0	0	1	8kHz ~ 48kHz	512fs
10	1	0	1	0	8kHz ~ 24kHz	1024fs
12	1	1	0	0	8kHz ~ 48kHz	384fs
13	1	1	0	1	8kHz ~ 24kHz	768fs
Others	Others				N/A	N/A

Default

Table 2. Relationship between Sampling Frequency and MCKI Frequency

	Master Mode (M/S bit = "1")	
	Power Up (PMDAC bit = "1")	Power Down (PMDAC bit = "0")
MCKI pin	Refer to Table 2	Input or fixed to "L" or "H" externally
BICK pin	BF bit = "1": 64fs output BF bit = "0": 32fs output	"L"
LRCK pin	Output	"L"

Table 3. Clock Operation in Master mode

	Slave Mode (M/S bit = "0")	
	Power Up (PMDAC bit = "1")	Power Down (PMDAC bit = "0")
MCKI pin	Refer to Table 2	Input or fixed to "L" or "H" externally
BICK pin	Input	Fixed to "L" or "H" externally
LRCK pin	Input	Fixed to "L" or "H" externally

Table 4. Clock Operation in Slave mode

For low sampling rates, DR and S/N degrade because of the out-of-band noise. DR and S/N are improved by using higher frequency for MCKI. Table 5 shows DR and S/N when the DAC output is to the HP-amp.

MCKI	DR, S/N (BW=20kHz, A-weight)	
	fs=8kHz	fs=16kHz
256fs/384fs/512fs	56dB	75dB
768fs/1024fs	75dB	90dB

Table 5. Relationship between MCKI frequency and DR (and S/N) of HP-amp (2.4V)

■ Serial Data Interface

The AK4370 interfaces with external systems via the SDATA, BICK and LRCK pins. Five data formats are available, selected by setting the DIF2, DIF1 and DIF0 bits (Table 6). Mode 0 is compatible with existing 16-bit DACs and digital filters. Mode 1 is a 20-bit version of Mode 0. Mode 4 is a 24-bit version of Mode 0. Mode 2 is similar to AKM ADCs and many DSP serial ports. Mode 3 is compatible with the I²S serial data protocol. In Modes 2 and 3 with BICK≥48fs, the following formats are also valid: 16-bit data followed by eight zeros (17th to 24th bits) and 20-bit data followed by four zeros (21st to 24th bits). In all modes, the serial data is MSB first and 2's complement format.

When master mode and BICK=32fs(BF bit = "0"), the AK4370 cannot be set to Mode 1, Mode 2 and Mode4.

Mode	DIF2	DIF1	DIF0	Format	BICK	Figure
0	0	0	0	0: 16bit, LSB justified	32fs ≤ BICK ≤ 64fs	Figure 13
1	0	0	1	1: 20bit, LSB justified	40fs ≤ BICK ≤ 64fs	Figure 14
2	0	1	0	2: 24bit, MSB justified	48fs ≤ BICK ≤ 64fs	Figure 15
3	0	1	1	3: I ² S Compatible	BICK=32fs or 48fs ≤ BICK ≤ 64fs	Figure 16
4	1	0	0	4: 24bit, LSB justified	48fs ≤ BICK ≤ 64fs	Figure 14

Default

Table 6. Audio Data Format

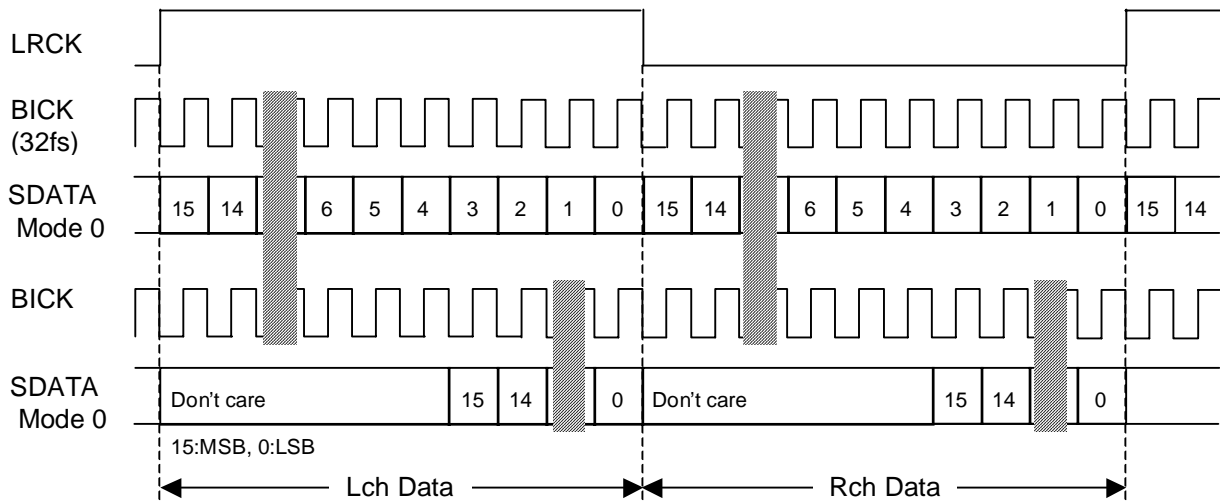

Figure 13. Mode 0 Timing (LRP = BCKP bits = "0")

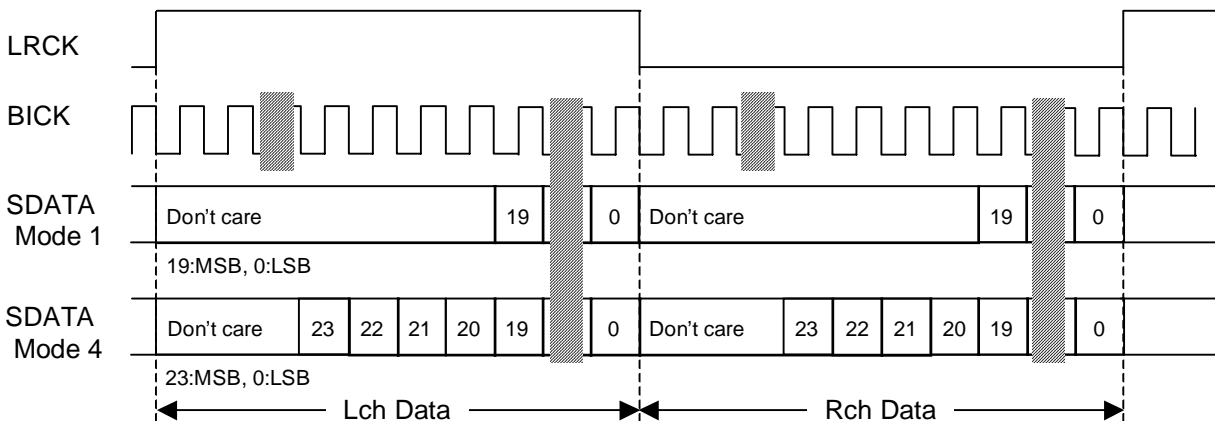

Figure 14. Mode 1, 4 Timing (LRP = BCKP bits = "0")

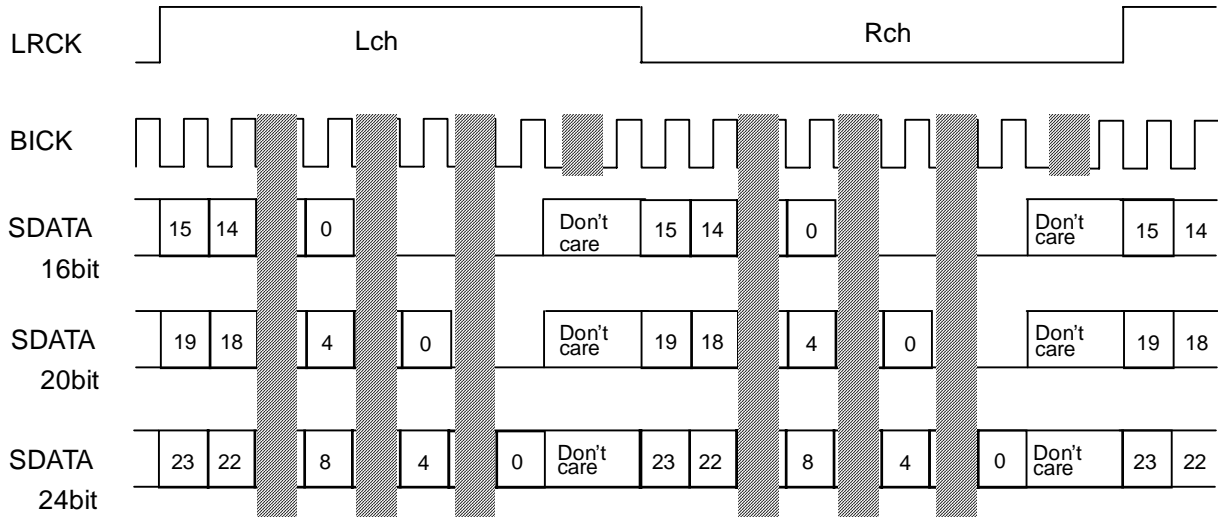

Figure 15. Mode 2 Timing (LRP = BCKP bits = "0")

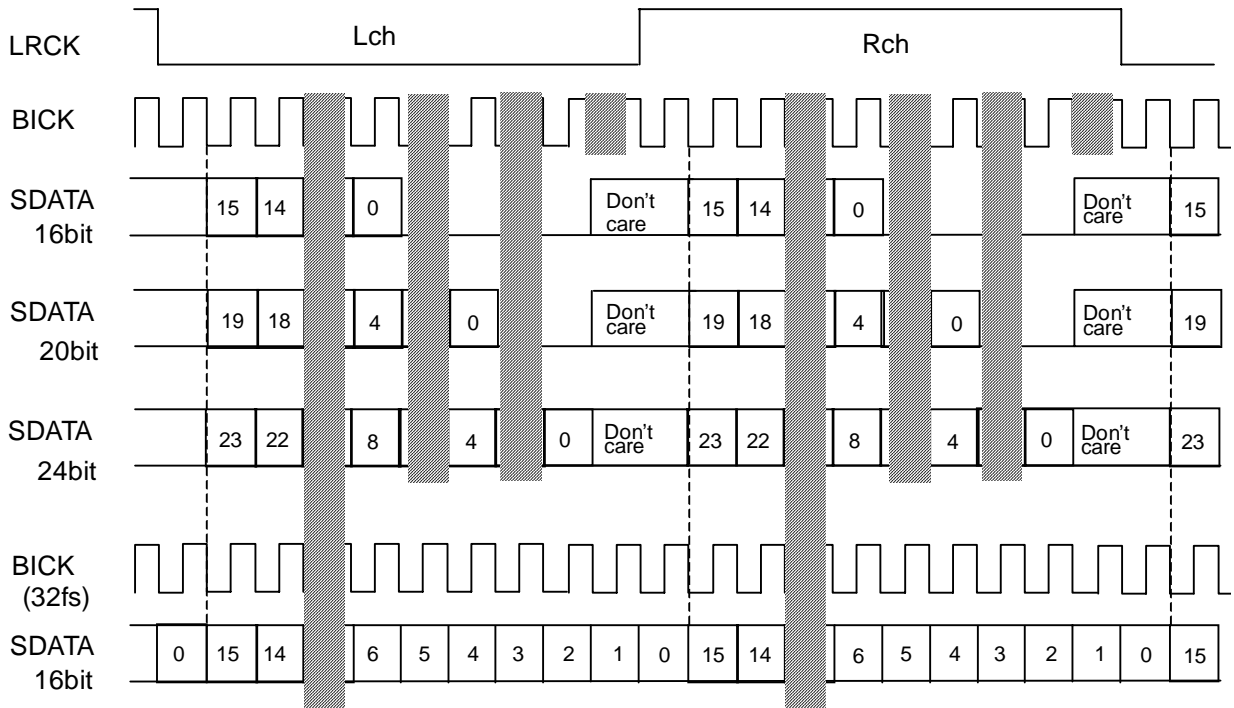

Figure 16. Mode 3 Timing (LRP = BCKP bits = "0")

■ Digital Attenuator

The AK4370 has a channel-independent digital attenuator (256 levels, 0.5dB step). This digital attenuator is placed before the D/A converter. ATTL/R7-0 bits set the attenuation level (0dB to -127dB or MUTE) for each channel (Table 7). At DATTC bit = "1", ATTL7-0 bits control both channel's attenuation levels. At DATTC bit = "0", ATTL7-0 bits control the left channel level and ATTR7-0 bits control the right channel level.

ATTL7-0 ATTR7-0	Attenuation
FFH	0dB
FEH	-0.5dB
FDH	-1.0dB
FCH	-1.5dB
:	:
:	:
02H	-126.5dB
01H	-127.0dB
00H	MUTE ($-\infty$)

Default

Table 7. Digital Volume ATT values

The ATS bit sets the transition time between set values of ATT7-0 bits as either 1061/fs or 7424/fs (Table 8). When the ATS bit = "0", a soft transition between the set values occurs(1062 levels). It takes 1061/fs (24ms@fs=44.1kHz) from FFH(0dB) to 00H(MUTE). The ATTs are 00H when the PMDAC bit is "0". When the PMDAC returns to "1", the ATTs fade to their current value. The digital attenuator is independent of the soft mute function.

ATS	ATT speed	
	0dB to MUTE	1 step
0	1061/fs	4/fs
1	7424/fs	29/fs

Default

Table 8. Transition time between set values of ATT7-0 bits

■ **Soft Mute**

Soft mute operation is performed in the digital domain. When the SMUTE bit goes to “1”, the output signal is attenuated by $-\infty$ during the $ATT_DATA \times ATT$ transition time (Table 8) from the current ATT level. When the SMUTE bit is returned to “0”, the mute is cancelled and the output attenuation gradually changes to the ATT level during $ATT_DATA \times ATT$ transition time. If the soft mute is cancelled before attenuating to $-\infty$ after starting the operation, the attenuation is discontinued and is returned to the ATT level by the same cycle. The soft mute is effective for changing the signal source without stopping the signal transmission.

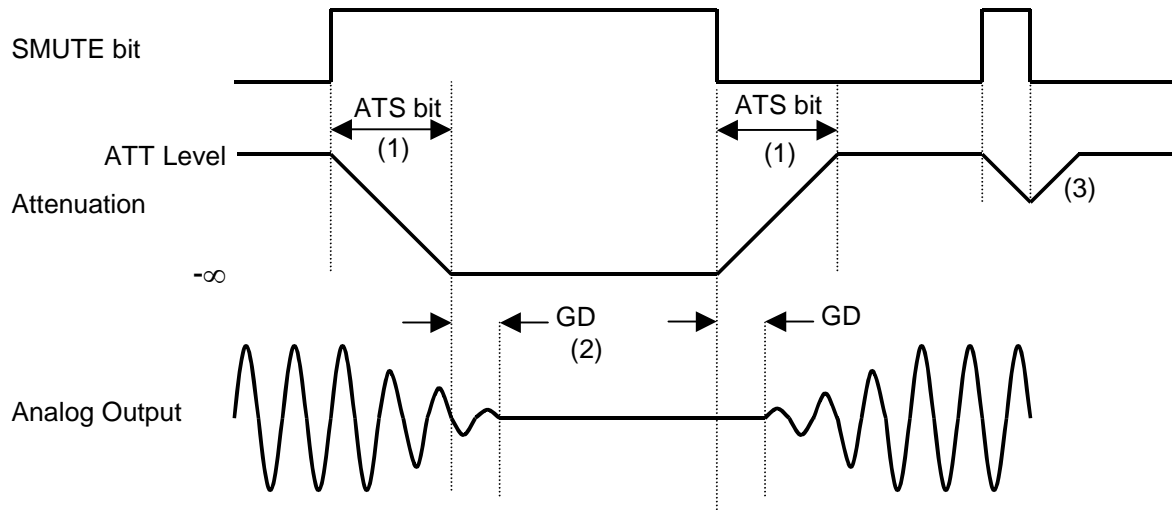

Figure 17. Soft Mute Function

Notes:

- (1) $ATT_DATA \times ATT$ transition time (Table 8). For example, this time is 3712LRCK cycles (3712/fs) at $ATS\ bit = "1"$ and $ATT_DATA = "128"$ (-63.5dB).
- (2) The analog output corresponding to the digital input has a group delay, GD.
- (3) If the soft mute is cancelled before attenuating to $-\infty$ after starting the operation, the attenuation is discontinued and it is returned to the ATT level by the same cycle.

■ De-emphasis Filter

The AK4370 includes a digital de-emphasis filter ($t_c = 50/15\mu s$), using an IIR filter corresponding to three sampling frequencies (32kHz, 44.1kHz and 48kHz). The de-emphasis filter is enabled by setting DEM1-0 bits (Table 9).

DEM1 bit	DEM0 bit	De-emphasis
0	0	44.1kHz
0	1	OFF
1	0	48kHz
1	1	32kHz

Default

Table 9. De-emphasis Filter Frequency Select

■ Bass Boost Function

By controlling the BST1-0 bits, a low frequency boost signal can be output from DAC. The setting value is common for both channels (Table 10).

BST1 bit	BST0 bit	BOOST
0	0	OFF
0	1	MIN
1	0	MID
1	1	MAX

Default

Table 10. Low Frequency Boost Select

■ Digital Mixing Function

MONO1-0 bits select the digital data mixing for the DAC (Table 11).

MONO1 bit	MONO0 bit	Lch	Rch
0	0	L	R
0	1	L	L
1	0	R	R
1	1	$(L+R)/2$	$(L+R)/2$

Default

Table 11. Mixer Setting

■ System Reset

PDN pin should be held to “L” upon power-up. The 4370 should be reset by bringing PDN pin “L” for 150ns or more. All of the internal register values are initialized by the system reset. After exiting reset, VCOM, DAC, HPL, HPR, LOUT and ROUT switch to the power-down state. The contents of the control register are maintained until the reset is completed.

The DAC exits reset and power down states by MCKI after the PMDAC bit is changed to “1”. The DAC is in power-down mode until MCKI is input.

■ Headphone Output (HPL, HPR pins)

The power supply voltage for the headphone-amp is supplied from the HVDD pin and is centered on the MUTET voltage. The headphone-amp output load resistance is 16Ω (min). When the MUTEN bit is “1” at PMHPL=PMHPR= “1”, the common voltage rises to 0.475 x AVDD. When the MUTEN bit is “0”, the common voltage of the headphone-amp falls and the outputs (HPL and HPR pins) go to VSS1.

t _r : Rise Time up to VCOM/2	70k x C (typ)
t _f : Fall Time down to VCOM/2	60k x C (typ)

Table 12. Headphone-Amp Rise/Fall Time

[Example] : Capacitor between the MUTET pin and ground = 1μF:
 Rise time up to VCOM/2: t_r = 70k x 1μ = 70ms (typ).
 Fall time down to VCOM/2: t_f = 60k x 1μ = 60ms (typ).

When the PMHPL and PMHPR bits are “0”, the headphone-amp is powered-down, and the outputs (HPL and HPR pins) go to VSS1.

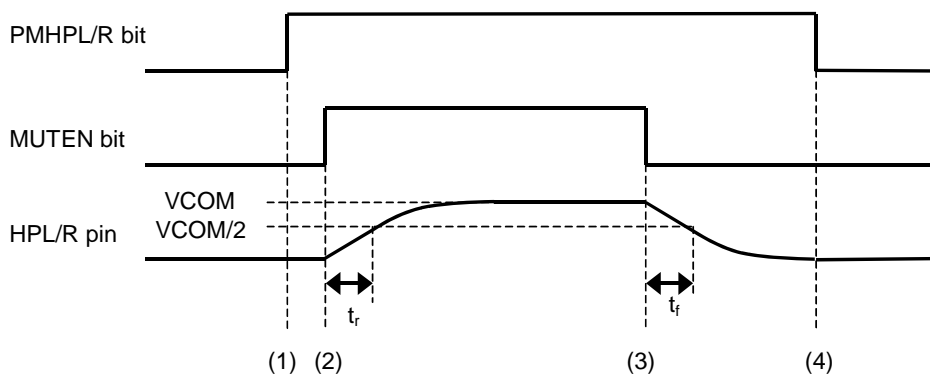

Figure 18. Power-up/Power-down Timing for the Headphone-Amp

- (1) Headphone-amp power-up (PMHPL and PMHPR bits = “1”). The outputs are still at VSS1.
- (2) Headphone-amp common voltage rises up (MUTEN bit = “1”). Common voltage of the headphone-amp is rising. This rise time depends on the capacitor value connected with the MUTET pin. The rise time up to VCOM/2 is t_r = 70k x C(typ) when the capacitor value on MUTET pin is “C”.
- (3) Headphone-amp common voltage falls down (MUTEN bit = “0”). Common voltage of the headphone-amp is falling to VSS1. This fall time depends on the capacitor value connected with the MUTET pin. The fall time down to VCOM/2 is t_f = 60k x C(typ) when the capacitor value on MUTET pin is “C”.
- (4) Headphone-amp power-down (PMHPL, PMHPR bits = “0”). The outputs are at VSS1. If the power supply is switched off or the headphone-amp is powered-down before the common voltage goes to VSS1, some pop noise may occur.

< External Circuit of Headphone-Amp >

The cut-off frequency of the headphone-amp output depends on the external resistor and capacitor used. Table 13 shows the cut off frequency and the output power for various resistor/capacitor combinations. The headphone impedance R_L is 16Ω . Output powers are shown at $AVDD = 2.4, 3.0$ and $3.3V$. The output voltage of the headphone-amp is $0.48 \times AVDD (V_{pp}) @ -3dBFS$.

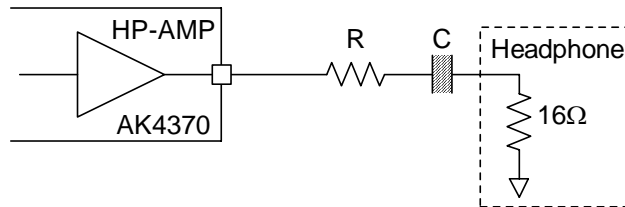

Figure 19. External Circuit Example of Headphone

R [Ω]	C [μF]	fc [Hz] BOOST=OFF	fc [Hz] BOOST=MIN	Output Power [mW]		
				2.4V	3.0V	3.3V
0	220	45	17	21	33	40
	100	100	43			
6.8	100	70	28	10	16	20
	47	149	78			
16	100	50	19	5	8	10
	47	106	47			

Table 13. Relationship of external circuit, output power and frequency response

< Wired OR with External Headphone-Amp >

When $PMVCM=PMHPL=PMHPR$ bits = “0” and HPZ bit = “1”, Headphone-amp is powered-down and HPL/R pins are pulled-down to $VSS1$ by $200k\Omega$ (typ). In this setting, it is available to connect headphone-amp of AK4370 and external single supply headphone-amp by “wired OR”.

PMVCM	PMHPL/R	HPMTN	HPZ	Mode	HPL/R pins
x	0	x	0	Power-down & Mute	$VSS1$
0	0	x	1	Power-down	Pull-down by $200k\Omega$
1	1	0	x	Mute	$VSS1$
1	1	1	x	Normal Operation	Normal Operation

Default

Table 14. HP-Amp Mode Setting (x: Don't care)

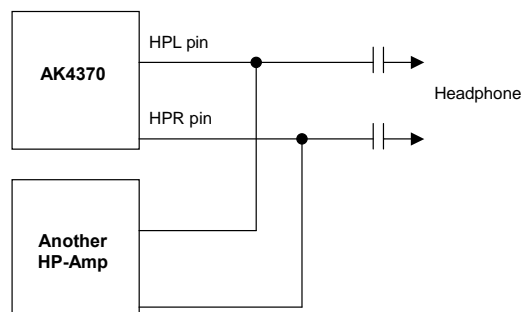

Figure 20. Wired OR with External HP-Amp

< Analog Mixing Circuit for Headphone Output >

DALHL, LIN1HL, RIN1HL, LIN2HL and RIN2HL bits control each path switch of HPL output. DARHR, LIN1HR, RIN1HR, LIN2HR and RIN2HR bits control each path switch of HPR output.

When L1HM=L2HM bits = “0”, HPG1-0 bits = “00” ($R_{1H} = R_{2H} = R_{DH} = 100k$) and ATTH4-0 bits = “00H” (0dB), the mixing gain is +0.95dB (typ). When HPG1-0 bit = “01” ($R_{DH} = 50k$), the mixing gain of DAC path is +6.95dB (typ). When HPG1-0 bit = “10” ($R_{DH} = 25k$), the mixing gain of DAC path is +12.95dB (typ). When L1HM and L2HM bits are “1”, LIN1/RIN1 and LIN2/RIN2 signals are output from HPL/R pins as $(L+R)/2$, respectively ($R_{1H} = R_{2H} = 200k$).

When LDIF=LDIFH=LIN1L=RIN1R bits = “1”, LIN1 and RIN1 pins becomes IN+ and IN- pins, respectively. IN+ and IN- pins can be used as full-differential mono line input for analog mixing for headphone-amp. In this case, LIN1HL, RIN1HL, LIN1HR and RIN1HR bits should be “0”.

If the path is OFF and the signal is input to the input pin, the input pin should be biased to a voltage equivalent to VCOM voltage ($= 0.475 \times AVDD$) externally. Figure 39 shows the external bias circuit example.

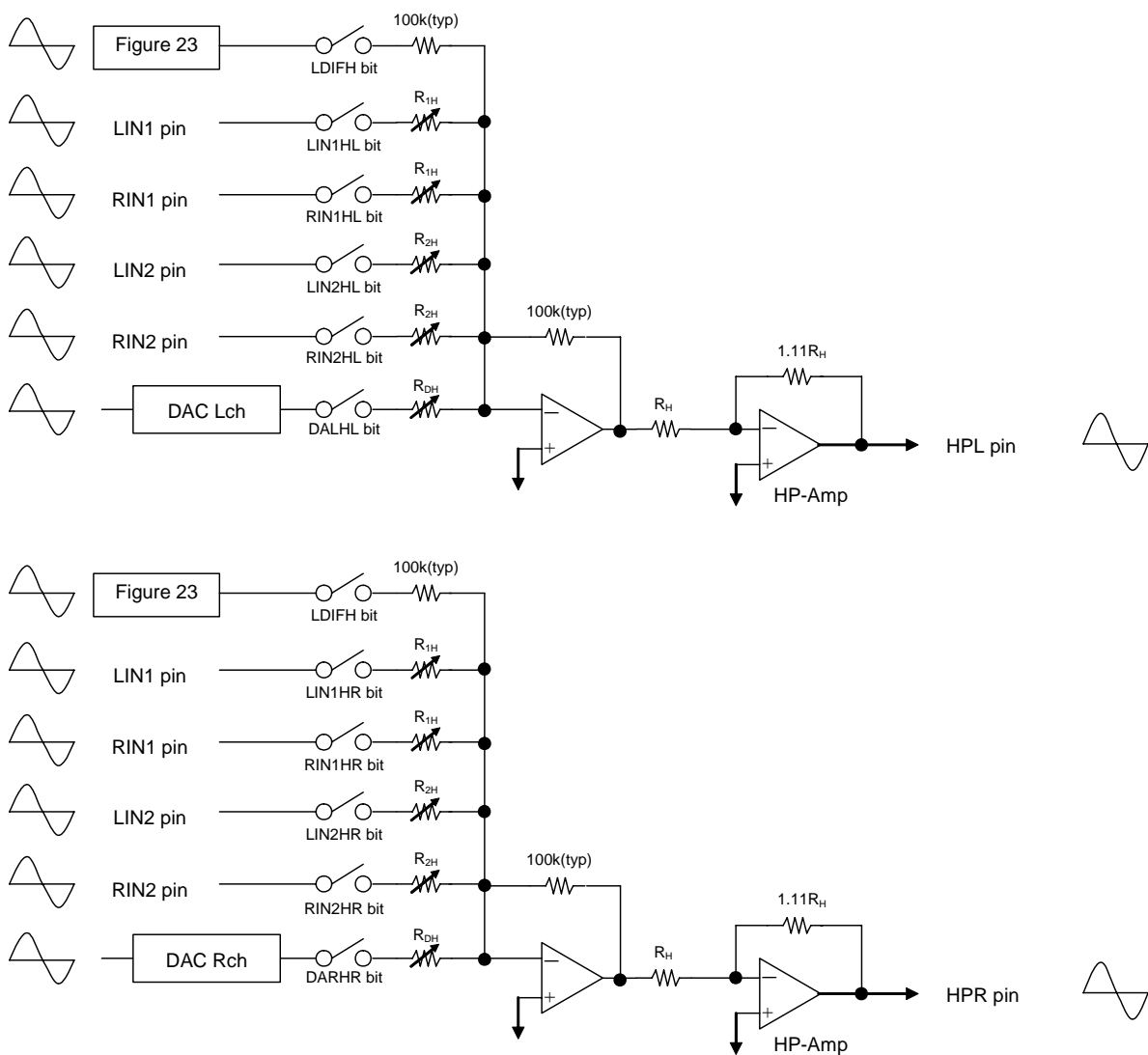

Figure 21. Summation circuit for HPL/R output

■ Headphone Output Volume

HPL/HPR volume is controlled by ATTH4-0 bit when HMUTE bit = “0” (+12dB ~ -51dB or +6dB ~ -57dB or 0dB ~ -63dB, 1.5dB or 3dB step, Table 15)

HMUTE	ATTH4-0	HPG1-0 bits = “10” (DAC Only)	HPG1-0 bits = “01” (DAC Only)	HPG1-0 bits = “00”	STEP
0	00H	+12dB	+6dB	0dB	1.5dB
	01H	+10.5dB	+4.5dB	-1.5dB	
	02H	+9dB	+3dB	-3dB	
	03H	+7.5dB	+1.5dB	-4.5dB	
	:	:	:	:	
	:	:	:	:	
	12H	-15dB	-21dB	-27dB	3dB
	13H	-16.5dB	-22.5dB	-28.5dB	
	14H	-18dB	-24dB	-30dB	
	15H	-21dB	-27dB	-33dB	
	16H	-24dB	-30dB	-36dB	
	:	:	:	:	
	:	:	:	:	
	1DH	-45dB	-51dB	-57dB	
	1EH	-48dB	-54dB	-60dB	
1FH	-51dB	-57dB	-63dB		
1	x	MUTE	MUTE	MUTE	

Table 15. HPL/HPR Volume ATT values (x: Don't care)

■ Stereo Line Output (LOUT, ROUT pins)

The common voltage is $0.475 \times AVDD$. The load resistance is $10k\Omega$ (min). When the PMLO bit is “1”, the stereo line output is powered-up. DALL, LIN1L, RIN1L, LIN2L and RIN2L bits control each path switch of LOUT. DARR, LIN1R, RIN1R, LIN2R and RIN2R bits control each path switch of ROUT. When L1M = L2M bits = “0”, LOG bit = “0” ($R_{1L} = R_{2L} = R_{DL} = 100k$) and ATTS3-0 bits is “0FH”(0dB), the mixing gain is 0dB(typ) for all paths. When the LOG bit = “1”($R_{DL} = 50k$), the DAC path gain is +6dB. When L1M = L2M bits = “1”, LIN1/RIN1 and LIN2/RIN2 signals are output from LOUT/ROUT pins as $(L+R)/2$, respectively ($R_{1L} = R_{2L} = 200k$).

If the path is OFF and the signal is input to the input pin, the input pin should be biased to a voltage equivalent to VCOM voltage ($= 0.475 \times AVDD$) externally. Figure 39 shows the external bias circuit example.

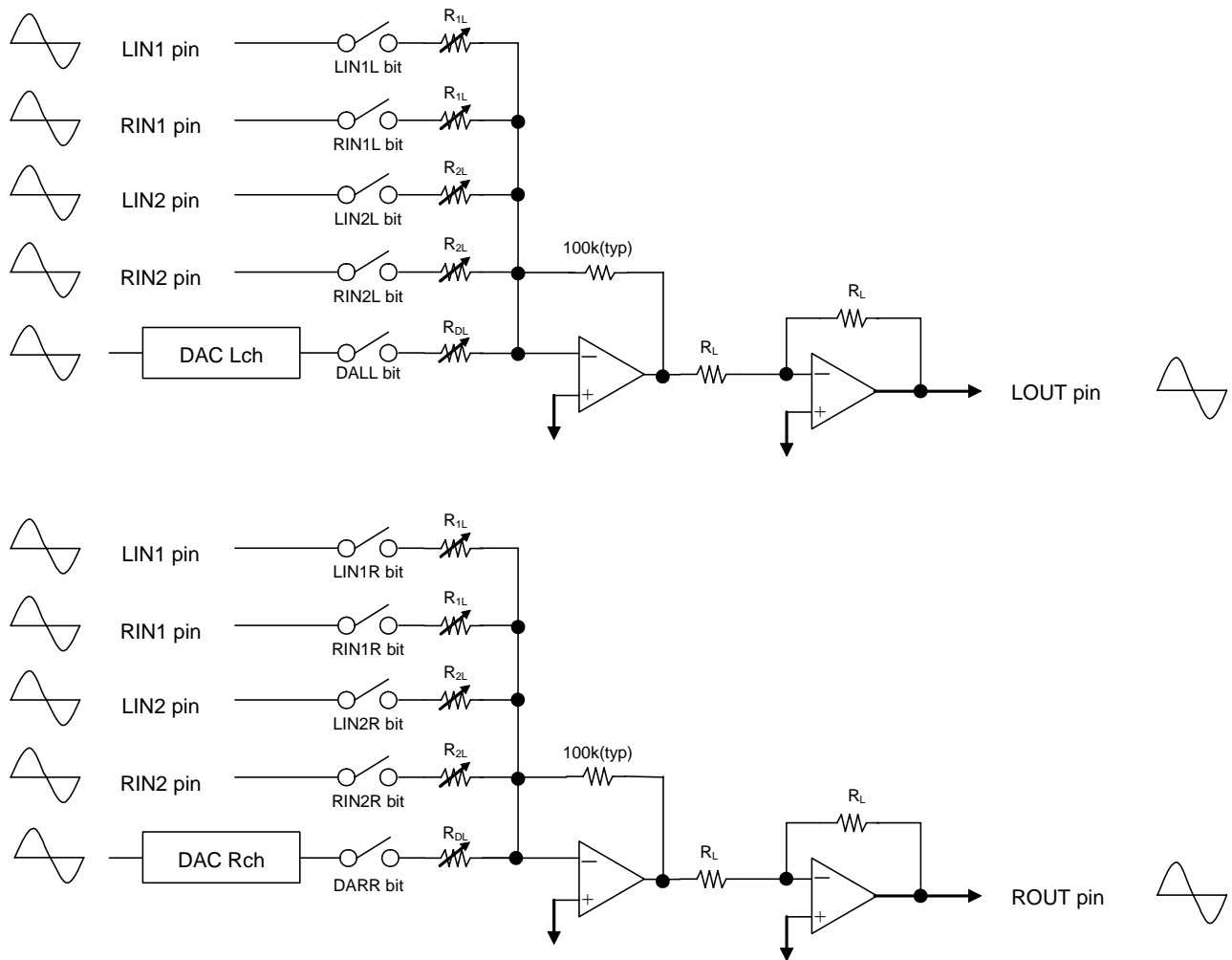

Figure 22. Summation circuit for stereo line output

< Analog Mixing Circuit of Full-differential Mono input >

When LDIF=LIN1L=RIN1R bits = “1”, LIN1 and RIN1 pins becomes IN+ and IN- pins, respectively. IN+ and IN- pins can be used as full-differential mono line input for analog mixing of LOUT/ROUT pins. It is not available to mix with other signal source for LOUT/ROUT outputs.

If the path is OFF and the signal is input to the input pin, the input pin should be biased to a voltage equivalent to VCOM voltage (= 0.475 x AVDD) externally. Figure 39 shows the external bias circuit example.

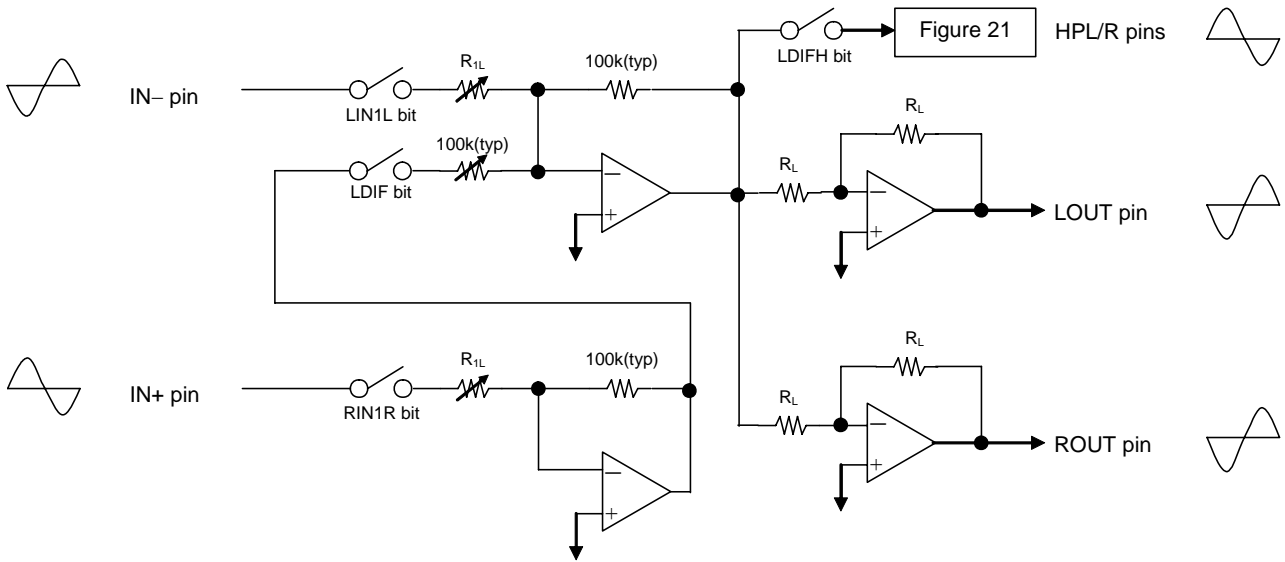

Figure 23. Summation circuit for stereo line output (Full-differential input, LOG bit = “0”)

■ Stereo Line Output (LOUT/ROUT pins) Volume

LOUT/ROUT volume is controlled by ATTS3-0 bits when LMUTE bit = “0” (+6dB ~ -24dB or 0dB ~ -30dB, 2dB step, Table 16). Pop noise occurs when ATTS3-0 bits are changed.

LMUTE	ATTS3-0	LOG bit = “1” (DAC Only)	LOG bit = “0”
0	FH	+6dB	0dB
	EH	+4dB	-2dB
	DH	+2dB	-4dB
	CH	0dB	-6dB
	:	:	:
	:	:	:
	1H	-22dB	-28dB
	0H	-24dB	-30dB
1	x	MUTE	MUTE

Default

Table 16. LOUT/ROUT Volume ATT values (x: Don’t care)

■ Power-Up/Down Sequence

1) DAC → HP-Amp

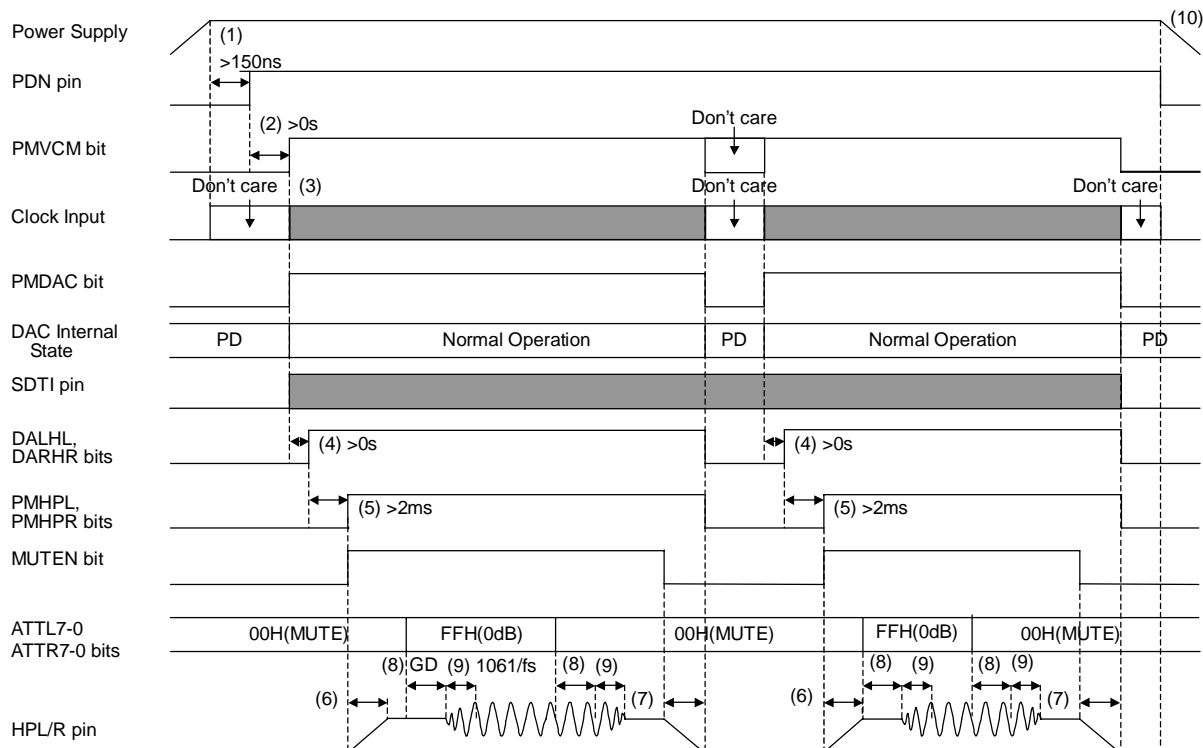

Figure 24. Power-up/down sequence of DAC and HP-amp (Don't care: except Hi-Z)

- (1) When AVDD and DVDD are supplied separately, AVDD should be powered-up after DVDD rises up to 1.6V or more. When AVDD and HVDD are supplied separately, AVDD should be powered-up at the same time or earlier than HVDD. PDN pin should be set to “H” at least 150ns after power is supplied.
- (2) PMVCM and PMDAC bits should be changed to “1” after PDN pin goes “H”.
- (3) External clocks (MCKI, BICK, LRCK) are needed to operate the DAC. When the PMDAC bit = “0”, these clocks can be stopped. The headphone-amp can operate without these clocks.
- (4) DALHL and DARHR bits should be changed to “1” after PMVCM and PMDAC bit is changed to “1”.
- (5) PMHPL, PMHPR and MUTEN bits should be changed to “1” at least 2ms (in case external capacitance at VCOM pin is 2.2μF) after the DALHL and DARHR bits are changed to “1”
- (6) Rise time of the headphone-amp is determined by an external capacitor (C) of the MUTET pin. The rise time up to VCOM/2 is $t_r = 70k \times C(\text{typ})$. When $C=1\mu\text{F}$, $t_r = 70\text{ms}(\text{typ})$.
- (7) Fall time of the headphone-amp is determined by an external capacitor (C) of the MUTET pin. The fall time down to VCOM/2 is $t_f = 60k \times C(\text{typ})$. When $C=1\mu\text{F}$, $t_f = 60\text{ms}(\text{typ})$.
PMHPL and PMHPR bits should be changed to “0” after HPL and HPR pins go to VSS1. After that, the DALHL and DARHR bits should be changed to “0”.
- (8) Analog output corresponding to the digital input has a group delay (GD) of $22/\text{fs}(=499\mu\text{s}@\text{fs}=44.1\text{kHz})$.
- (9) The ATS bit sets transition time of digital attenuator. Default value is $1061/\text{fs}(=24\text{ms}@\text{fs}=44.1\text{kHz})$.
- (10) The power supply should be switched off after the headphone-amp is powered down (HPL/R pins become “L”).
When AVDD and DVDD are supplied separately, DVDD should be powered-down at the same time or later than AVDD. When AVDD and HVDD are supplied separately, AVDD should be powered-down at the same time or later than HVDD.

2) DAC → Lineout

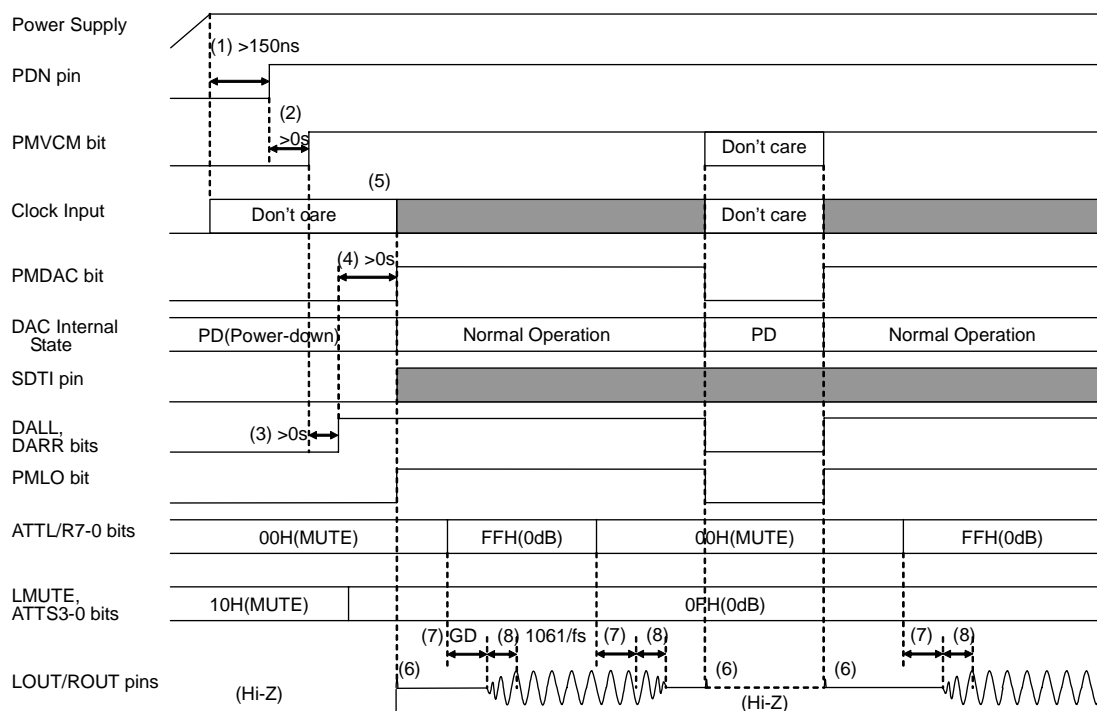

Figure 25. Power-up/down sequence of DAC and LOUT/ROUT (Don't care: except Hi-Z)

- (1) When AVDD and DVDD are supplied separately, AVDD should be powered-up after DVDD rises up to 1.6V or more. When AVDD and HVDD are supplied separately, AVDD should be powered-up at the same time or earlier than HVDD. PDN pin should be set to “H” at least 150ns after power is supplied.
- (2) PMVCM bit should be changed to “1” after the PDN pin goes “H”.
- (3) DALL and DARR bits should be changed to “1” after the PMVCM bit is changed to “1”.
- (4) PMDAC and PMLO bits should be changed to “1” after DALL and DARR bits is changed to “1”.
- (5) External clocks (MCKI, BICK, LRCK) are needed to operate the DAC. When the PMDAC bit = “0”, these clocks can be stopped. The LOUT/ROUT buffer can operate without these clocks.
- (6) When the PMLO bit is changed, pop noise is output from LOUT/ROUT pins.
- (7) Analog output corresponding to the digital input has a group delay (GD) of $22\text{fs}(=499\mu\text{s}@\text{fs}=44.1\text{kHz})$.
- (8) The ATS bit sets the transition time of the digital attenuator. Default value is $1061/\text{fs}(=24\text{ms}@\text{fs}=44.1\text{kHz})$.

3) LIN1/RIN1/LIN2/RIN2 → HP-Amp

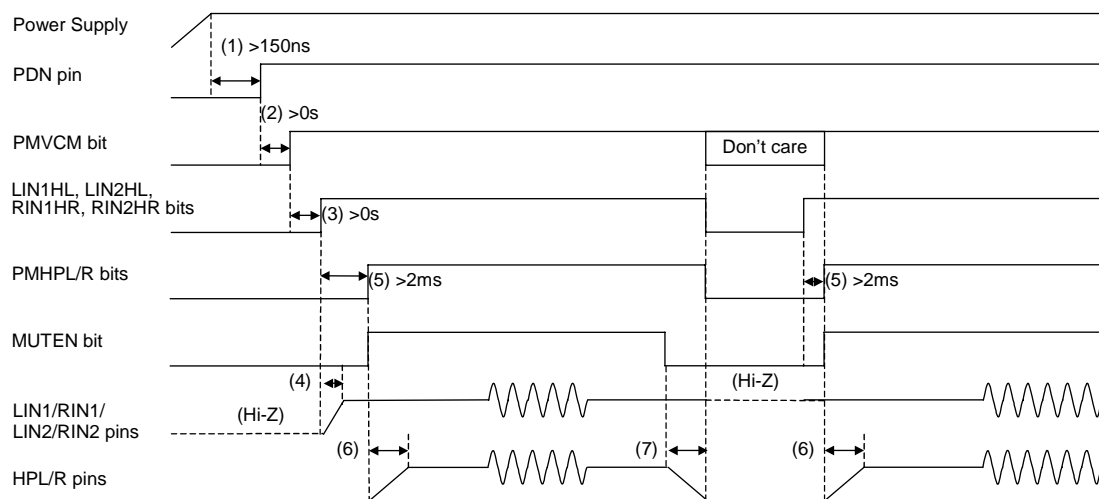

Figure 26. Power-up/down sequence of LIN1/RIN1/LIN2/RIN2 and HP-Amp

- (1) When AVDD and DVDD are supplied separately, AVDD should be powered-up after DVDD rises up to 1.6V or more. When AVDD and HVDD are supplied separately, AVDD should be powered-up at the same time or earlier than HVDD. PDN pin should be set to “H” at least 150ns after power is supplied. MCKI, BICK and LRCK can be stopped when DAC is not used.
- (2) PMVCM bit should be changed to “1” after PDN pin goes “H”.
- (3) LIN1HL, LIN2HL, RIN1HR and RIN2HR bits should be changed to “1” after PMVCM bit is changed to “1”.
- (4) When LIN1HL, LIN2HL, RIN1HR or RIN2HR bit is changed to “1”, LIN1, RIN1, LIN2 or RIN2 pin is biased to $0.475 \times AVDD$.
- (5) PMHPL, PMHPR and MUTEN bits should be changed to “1” at least 2ms (in case external capacitance at VCOM pin is $2.2\mu\text{F}$) after LIN1HL, LIN2HL, RIN1HR and RIN2HR bits are changed to “1”.
- (6) Rise time of the headphone-amp is determined by an external capacitor (C) of the MUTET pin. The rise time up to $V_{COM}/2$ is $t_r = 70k \times C(\text{typ})$. When $C=1\mu\text{F}$, $t_r = 70\text{ms}(\text{typ})$.
- (7) Fall time of the headphone-amp is determined by an external capacitor (C) of the MUTET pin. The fall time down to $V_{COM}/2$ is $t_f = 60k \times C(\text{typ})$. When $C=1\mu\text{F}$, $t_f = 60\text{ms}(\text{typ})$. PMHPL and PMHPR bits should be changed to “0” after HPL and HPR pins go to VSS1. After that, the LIN1HL, LIN2HL, RIN1HR and RIN2HR bits should be changed to “0”.

4) LIN1/RIN1/LIN2/RIN2 → Lineout

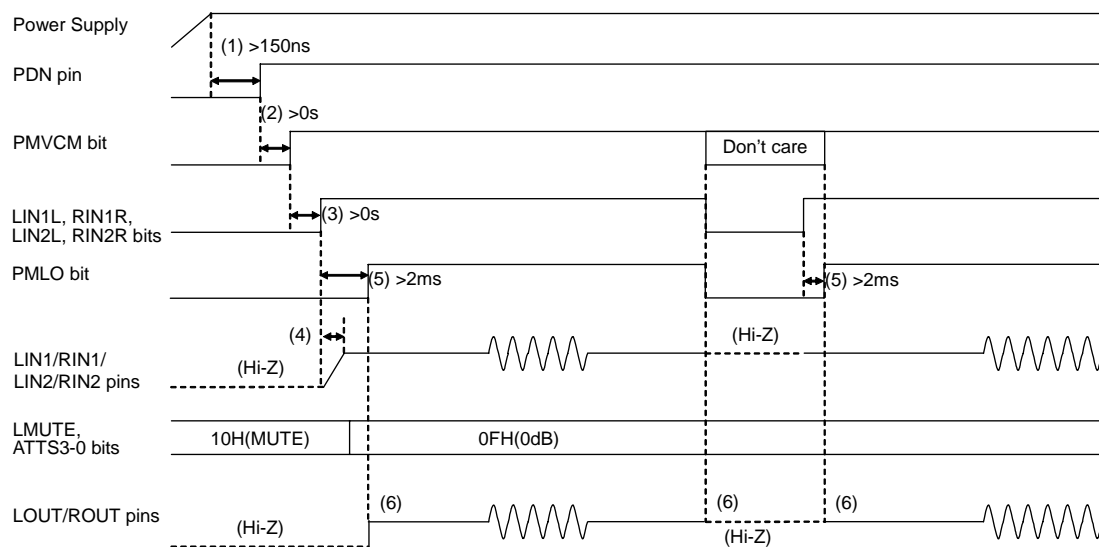

Figure 27. Power-up/down sequence of LIN1/RIN1/LIN2/RIN2 and Lineout

- (1) When AVDD and DVDD are supplied separately, AVDD should be powered-up after DVDD rises up to 1.6V or more. When AVDD and HVDD are supplied separately, AVDD should be powered-up at the same time or earlier than HVDD. PDN pin should be set to “H” at least 150ns after power is supplied. MCKI, BICK and LRCK can be stopped when DAC is not used.
- (2) PMVCM bit should be changed to “1” after PDN pin goes “H”.
- (3) LIN1L, LIN2L, RIN1R and RIN2R bits should be changed to “1” after PMVCM bit is changed to “1”.
- (4) When LIN1L, LIN2L, RIN1R or RIN2R bit is changed to “1”, LIN1, RIN1, LIN2 or RIN2 pin is biased to $0.475 \times \text{AVDD}$.
- (5) PMLO bit should be changed to “1” at least 2ms (in case external capacitance at VCOM pin is $2.2\mu\text{F}$) after LIN1L, LIN2L, RIN1R and RIN2R bits are changed to “1”.
- (6) When the PMLO bit is changed, pop noise is output from LOUT/ROUT pins.

■ Serial Control Interface

(1) 3-wire Serial Control Mode (I2C pin = "L")

Internal registers may be written to via the 3-wire μ P interface pins (CSN, CCLK and CDTI). The data on this interface consists of the Chip address (2-bits, Fixed to "01"), Read/Write (1-bit, Fixed to "1", Write only), Register address (MSB first, 5-bits) and Control data (MSB first, 8-bits). Address and data are clocked in on the rising edge of CCLK. For write operations, the data is latched after a low-to-high transition of the 16th CCLK. CSN should be set to "H" once after 16 CCLKs for each address. The clock speed of CCLK is 5MHz(max). The value of the internal registers is initialized at PDN pin = "L".

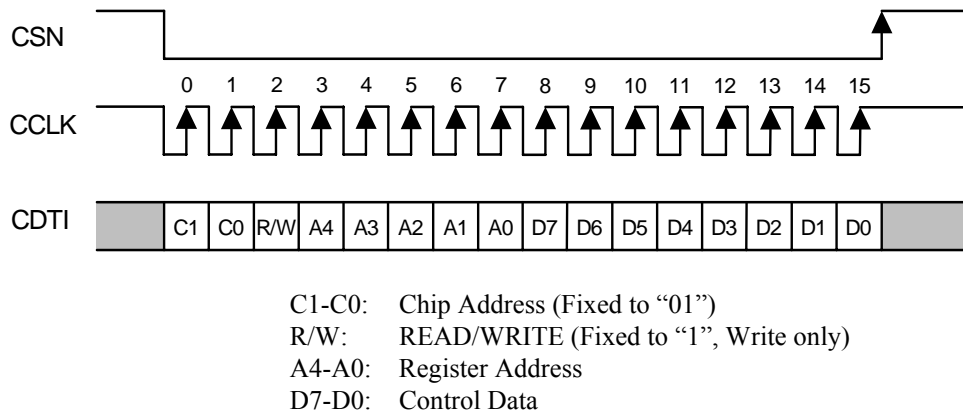

Figure 28. 3-wire Serial Control I/F Timing

(2) I²C-bus Control Mode (I2C pin = "H")

The AK4370 supports fast-mode I²C-bus (max: 400kHz, Version 1.0).

(2)-1. WRITE Operations

Figure 29 shows the data transfer sequence for the I²C-bus mode. All commands are preceded by a START condition. A HIGH to LOW transition on the SDA line while SCL is HIGH indicates a START condition (Figure 35). After the START condition, a slave address is sent. This address is 7 bits long followed by the eighth bit that is a data direction bit (R/W). The most significant six bits of the slave address are fixed as "001000". The next bit is CAD0 (device address bit). This bit identifies the specific device on the bus. The hard-wired input pin (CAD0 pin) sets this device address bit (Figure 30). If the slave address matches that of the AK4370, the AK4370 generates an acknowledgement and the operation is executed. The master must generate the acknowledge-related clock pulse and release the SDA line (HIGH) during the acknowledge clock pulse (Figure 36). A R/W bit value of "1" indicates that the read operation is to be executed. A "0" indicates that the write operation is to be executed.

The second byte consists of the control register address of the AK4370. The format is MSB first, and those most significant 3-bits are fixed to zeros (Figure 31). The data after the second byte contains control data. The format is MSB first, 8bits (Figure 32). The AK4370 generates an acknowledgement after each byte has been received. A data transfer is always terminated by a STOP condition generated by the master. A LOW to HIGH transition on the SDA line while SCL is HIGH defines a STOP condition (Figure 35).

The AK4370 can perform more than one byte write operation per sequence. After receiving the third byte the AK4370 generates an acknowledgement and awaits the next data. The master can transmit more than one byte instead of terminating the write cycle after the first data byte is transferred. After receiving each data packet the internal 5-bit address counter is incremented by one, and the next data is automatically taken into the next address. If the address exceeds 13H prior to generating the stop condition, the address counter will "roll over" to 00H and the previous data will be overwritten.

The data on the SDA line must remain stable during the HIGH period of the clock. The HIGH or LOW state of the data line can only change when the clock signal on the SCL line is LOW(Figure 37) except for the START and STOP conditions.

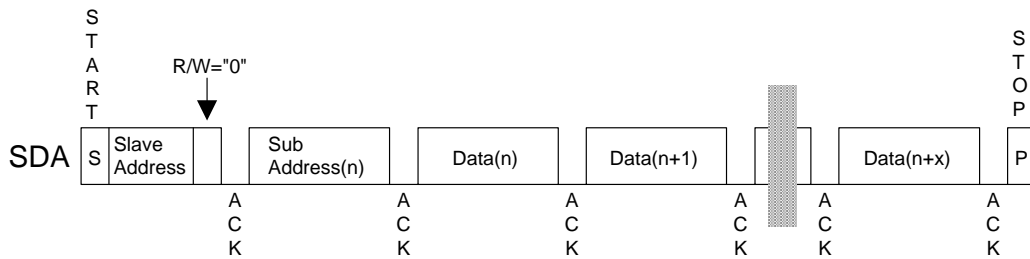
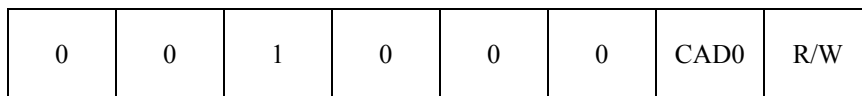

Figure 29. Data Transfer Sequence at the I²C-Bus Mode



(Those CAD0 should match with CAD0 pin)

Figure 30. The First Byte

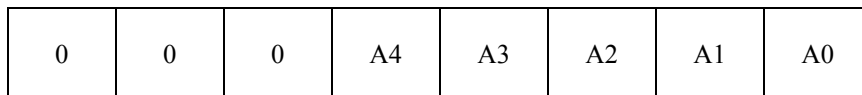

Figure 31. The Second Byte

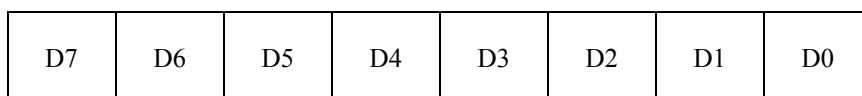

Figure 32. Byte Structure after the second byte

(2)-2. READ Operations

Set the R/W bit = "1" for the READ operation of the AK4370. After a transmission of data, the master can read the next address's data by generating an acknowledge instead of terminating the writing cycle after receiving the first data word. After receiving each data packet the internal 5-bit address counter is incremented by one, and the next data is automatically taken into the next address. If the address exceeds 13H prior to generating a stop condition, the address counter will "roll over" to 00H and the previous data will be overwritten.

The AK4370 supports two basic read operations: CURRENT ADDRESS READ and RANDOM ADDRESS READ.

(2)-2-1. CURRENT ADDRESS READ

The AK4370 contains an internal address counter that maintains the address of the last word accessed, incremented by one. Therefore, if the last access (either a read or write) were to address n, the next CURRENT READ operation would access data from the address n+1. After receiving the slave address with R/W bit set to "1", the AK4370 generates an acknowledge, transmits 1-byte of data to the address set by the internal address counter and increments the internal address counter by 1. If the master does not generate an acknowledgement to the data but instead generates a stop condition, the AK4370 ceases transmission.

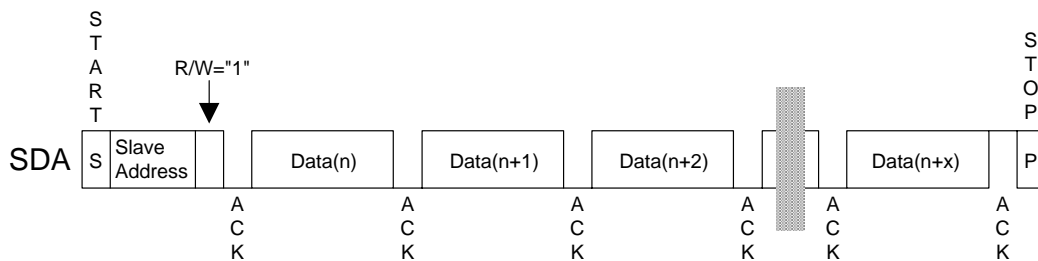

Figure 33. CURRENT ADDRESS READ

(2)-2-2. RANDOM ADDRESS READ

The random read operation allows the master to access any memory location at random. Prior to issuing the slave address with the R/W bit set to "1", the master must first perform a "dummy" write operation. The master issues a start request, a slave address (R/W bit = "0") and then the register address to read. After the register address is acknowledged, the master immediately reissues the start request and the slave address with the R/W bit set to "1". The AK4370 then generates an acknowledgement, 1 byte of data and increments the internal address counter by 1. If the master does not generate an acknowledgement to the data but instead generates a stop condition, the AK4370 ceases transmission.

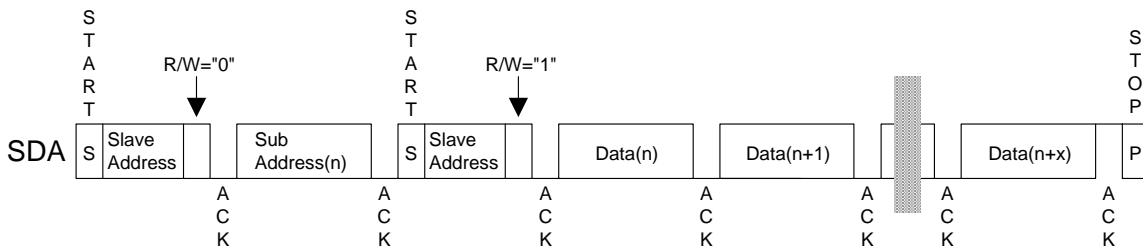

Figure 34. RANDOM ADDRESS READ

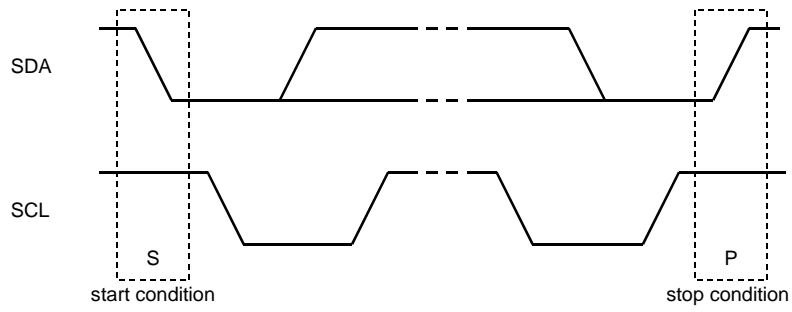

Figure 35. START and STOP Conditions

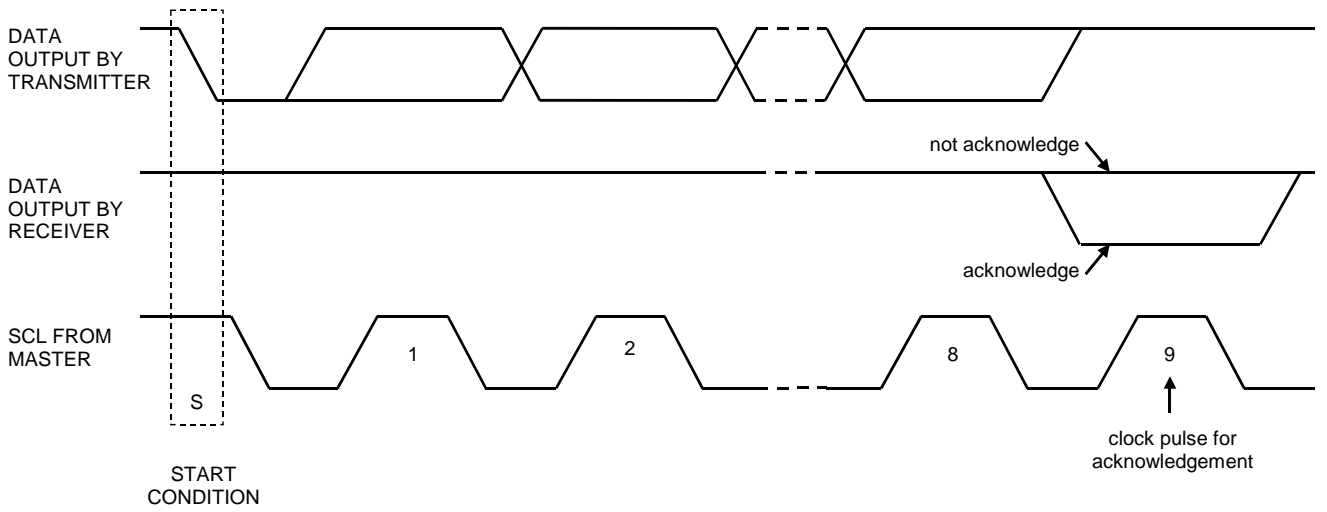

Figure 36. Acknowledge on the I²C-Bus

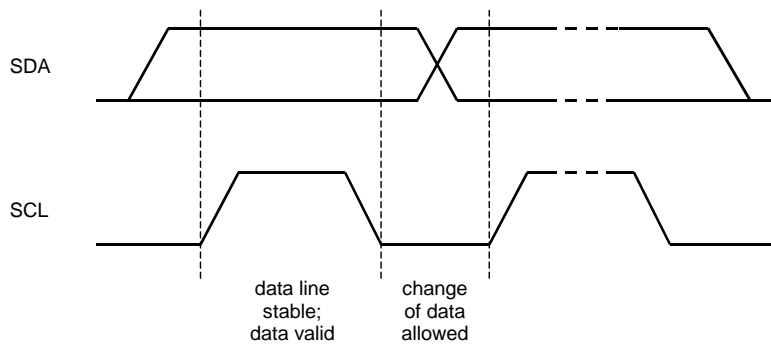

Figure 37. Bit Transfer on the I²C-Bus

■ Register Map

Addr	Register Name	D7	D6	D5	D4	D3	D2	D1	D0
00H	Power Management	0	0	PMLO	MUTEN	PMHPR	PMHPL	PMDAC	PMVCM
01H	Clock Control 0	FS3	FS2	FS1	FS0	0	0	0	0
02H	Clock Control 1	0	0	M/S	MCKAC	BF	0	0	0
03H	Mode Control 0	0	MONO1	MONO0	BCKP	LRP	DIF2	DIF1	DIF0
04H	Mode Control 1	ATS	DATTC	LMUTE	SMUTE	BST1	BST0	DEM1	DEM0
05H	DAC Lch ATT	ATTL7	ATTL6	ATTL5	ATTL4	ATTL3	ATTL2	ATTL1	ATTL0
06H	DAC Rch ATT	ATTR7	ATTR6	ATTR5	ATTR4	ATTR3	ATTR2	ATTR1	ATTR0
07H	Headphone Out Select 0	HPG1	HPG0	LIN2HR	LIN2HL	RIN1HR	LIN1HL	DARHR	DALHL
08H	Lineout Select 0	0	LOG	LIN2R	LIN2L	RIN1R	LIN1L	DARR	DALL
09H	Lineout ATT	0	0	0	0	ATTS3	ATTS2	ATTS1	ATTS0
0AH	Reserved	0	0	0	0	0	0	0	0
0BH	Reserved	0	0	0	0	0	0	0	0
0CH	Reserved	0	0	0	0	0	0	0	0
0DH	Headphone Out Select 1	0	0	0	0	RIN2HR	RIN2HL	LIN1HR	RIN1HL
0EH	Headphone ATT	0	HPZ	HMUTE	ATTH4	ATTH3	ATTH2	ATTH1	ATTH0
0FH	Lineout Select 1	0	0	0	0	RIN2R	RIN2L	LIN1R	RIN1L
10H	Mono Mixing	0	0	0	0	L2M	L2HM	L1M	L1HM
11H	Differential Select	0	0	0	0	0	0	LDIFH	LDIF
12H	Reserved	0	0	0	0	0	0	0	0
13H	Reserved	0	0	0	1	0	0	0	0

All registers inhibit writing at PDN pin = "L".

PDN pin = "L" resets the registers to their default values.

For addresses from 14H to 1FH, data must not be written.

Unused bits must contain a "0" value.

Unused bits must contain a "1" value

■ Register Definitions

Addr	Register Name	D7	D6	D5	D4	D3	D2	D1	D0
00H	Power Management 0	0	0	PMLO	MUTEN	PMHPR	PMHPL	PMDAC	PMVCM
	R/W	RD	RD	R/W	R/W	R/W	R/W	R/W	R/W
	Default	0	0	0	0	0	0	0	0

PMVCM: Power Management for VCOM Block

0: Power OFF (Default)

1: Power ON

PMDAC: Power Management for DAC Blocks

0: Power OFF (Default)

1: Power ON

When the PMDAC bit is changed from “0” to “1”, the DAC is powered-up to the current register values (ATT value, sampling rate, etc).

PMHPL: Power Management for the left channel of the headphone-amp

0: Power OFF (Default). HPL pin goes to VSS1(0V).

1: Power ON

PMHPR: Power Management for the right channel of the headphone-amp

0: Power OFF (Default). HPR pin goes to VSS1(0V).

1: Power ON

MUTEN: Headphone Amp Mute Control

0: Mute (Default). HPL and HPR pins go to VSS1(0V).

1: Normal operation. HPL and HPR pins go to $0.475 \times AVDD$.

PMLO: Power Management for Stereo Output

0: Power OFF (Default) LOUT/ROUT pins go to Hi-Z.

1: Power ON

Each block can be powered-down respectively by writing “0” in each bit of this address. When the PDN pin is “L”, all blocks are powered-down regardless as setting of this address. In this case, register is initialized to the default value.

When PMVCM, PMDAC, PMHPL, PMHPR and PMLO bits are “0”, all blocks are powered-down. The register values remain unchanged. Power supply current is $20\mu\text{A}$ (typ) in this case. For fully shut down (typ. $1\mu\text{A}$), PDN pin should be “L”.

Addr	Register Name	D7	D6	D5	D4	D3	D2	D1	D0
01H	Clock Control 0	FS3	FS2	FS1	FS0	0	0	0	0
	R/W	R/W	R/W	R/W	R/W	RD	RD	RD	RD
	Default	1	0	0	0	0	0	0	0

FS3-0: Sampling Frequency select
See Table 2.

Addr	Register Name	D7	D6	D5	D4	D3	D2	D1	D0
02H	Clock Control 1	0	0	M/S	MCKAC	BF	0	0	0
	R/W	RD	RD	R/W	R/W	R/W	RD	RD	RD
	Default	0	0	0	0	0	0	0	0

BF: BICK Period setting in Master Mode. In slave mode, this bit is ignored.
0: 32fs (Default)
1: 64fs

MCKAC: MCKI Input Mode Select
0: CMOS input (Default)
1: AC coupling input

M/S: Master/Slave Mode Select
0: Slave mode (Default)
1: Master mode

Addr	Register Name	D7	D6	D5	D4	D3	D2	D1	D0
03H	Mode Control 0	0	MONO1	MONO0	BCKP	LRP	DIF2	DIF1	DIF0
	R/W	RD	R/W	R/W	R/W	R/W	R/W	R/W	R/W
	Default	0	0	0	0	0	0	1	0

DIF2-0: Audio Data Interface Format Select (Table 6)
Default: "010" (Mode 2)

LRP: LRCK Polarity Select in Slave Mode
0: Normal (Default)
1: Invert

BCKP: BICK Polarity Select in Slave Mode
0: Normal (Default)
1: Invert

MONO1-0: Mixing Select (Table 11)
Default: "00" (LR)

Addr	Register Name	D7	D6	D5	D4	D3	D2	D1	D0
04H	Mode Control 1	ATS	DATTC	LMUTE	SMUTE	BST1	BST0	DEM1	DEM0
	R/W	R/W	R/W	R/W	R/W	R/W	R/W	R/W	R/W
	Default	0	0	1	0	0	0	0	1

DEM1-0: De-emphasis Filter Frequency Select (Table 9)

Default: "01" (OFF)

BST1-0: Low Frequency Boost Function Select (Table 10)

Default: "00" (OFF)

SMUTE: Soft Mute Control

0: Normal operation (Default)

1: DAC outputs soft-muted

LMUTE: Mute control for LOUT/ROUT (Note 19)

0: Normal operation. ATTS3-0 bits control attenuation value.

1: Mute. ATTS3-0 bits are ignored. (Default)

DATTC: DAC Digital Attenuator Control Mode Select

0: Independent (Default)

1: Dependent

At DATTC bit = "1", ATTL7-0 bits control both channel attenuation levels, while register values of ATTL7-0 bits are not written to the ATTR7-0 bits. At DATTC bit = "0", the ATTL7-0 bits control the left channel level and the ATTR7-0 bits control the right channel level.

ATS: Digital attenuator transition time setting (Table 8)

0: 1061/fs (Default)

1: 7424/fs

Addr	Register Name	D7	D6	D5	D4	D3	D2	D1	D0
05H	DAC Lch ATT	ATTL7	ATTL6	ATTL5	ATTL4	ATTL3	ATTL2	ATTL1	ATTL0
06H	DAC Rch ATT	ATTR7	ATTR6	ATTR5	ATTR4	ATTR3	ATTR2	ATTR1	ATTR0
	R/W	R/W	R/W	R/W	R/W	R/W	R/W	R/W	R/W
	Default	0	0	0	0	0	0	0	0

ATTL7-0: Setting of the attenuation value of output signal from DACL (Table 7)

ATTR7-0: Setting of the attenuation value of output signal from DACR (Table 7)

Default: "00H" (MUTE)

Addr	Register Name	D7	D6	D5	D4	D3	D2	D1	D0
07H	Headphone Out Select 0	HPG1	HPG0	LIN2HR	LIN2HL	RIN1HR	LIN1HL	DARHR	DALHL
	R/W	R/W	R/W	R/W	R/W	R/W	R/W	R/W	R/W
	Default	0	0	0	0	0	0	0	0

DALHL: DAC left channel output signal is added to the left channel of the headphone-amp.

0: OFF (Default)

1: ON

DARHR: DAC right channel output signal is added to the right channel of the headphone-amp.

0: OFF (Default)

1: ON

LIN1HL: Input signal to LIN1 pin is added to the left channel of the headphone-amp.

0: OFF (Default)

1: ON

RIN1HR: Input signal to RIN1 pin is added to the right channel of the headphone-amp.

0: OFF (Default)

1: ON

LIN2HL: Input signal to LIN2 pin is added to the left channel of the headphone-amp.

0: OFF (Default)

1: ON

LIN2HR: Input signal to LIN2 pin is added to the right channel of the headphone-amp.

0: OFF (Default)

1: ON

HPG1-0: DAC → HPL/R Gain (Note 18)

Default: "00": +0.95dB

Addr	Register Name	D7	D6	D5	D4	D3	D2	D1	D0
08H	Lineout Select 0	0	LOG	LIN2R	LIN2L	RIN1R	LIN1L	DARR	DALL
	R/W	RD	R/W	R/W	R/W	R/W	R/W	R/W	R/W
	Default	0	0	0	0	0	0	0	0

DALL: DAC left channel output is added to the LOUT buffer amp.

0: OFF (Default)

1: ON

DARR: DAC right channel output is added to the ROUT buffer amp.

0: OFF (Default)

1: ON

LIN1L: Input signal to the LIN1 pin is added to the LOUT buffer amp.

0: OFF (Default)

1: ON

RIN1R: Input signal to the RIN1 pin is added to the ROUT buffer amp.

0: OFF (Default)

1: ON

LIN2L: Input signal to the LIN2 pin is added to the LOUT buffer amp.

0: OFF (Default)

1: ON

LIN2R: Input signal to the LIN2 pin is added to the ROUT buffer amp.

0: OFF (Default)

1: ON

LOG: DAC → LOUT/ROUT Gain

0: 0dB (Default)

1: +6dB

Addr	Register Name	D7	D6	D5	D4	D3	D2	D1	D0
09H	Lineout ATT	0	0	0	0	ATTS3	ATTS2	ATTS1	ATTS0
	R/W	RD	RD	RD	RD	R/W	R/W	R/W	R/W
	Default	0	0	0	0	0	0	0	0

ATTS3-0: Analog volume control for LOUT/ROUT (Table 16)

Default: LMUTE bit = "1", ATTS3-0 bits = "0000" (MUTE)

Setting of ATTS3-0 bits is enabled at LMUTE bit is "0".

Addr	Register Name	D7	D6	D5	D4	D3	D2	D1	D0
0DH	Headphone Out Select 1	0	0	0	0	RIN2HR	RIN2HL	LIN1HR	RIN1HL
	R/W	RD	RD	RD	RD	R/W	R/W	R/W	R/W
	Default	0	0	0	0	0	0	0	0

RIN1HL: RIN1 signal is added to the left channel of the Headphone-Amp

0: OFF (Default)

1: ON

LIN1HR: LIN1 signal is added to the right channel of the Headphone-Amp

0: OFF (Default)

1: ON

RIN2HL: RIN2 signal is added to the left channel of the Headphone-Amp

0: OFF (Default)

1: ON

RIN2HR: RIN2 signal is added to the right channel of the Headphone-Amp

0: OFF (Default)

1: ON

Addr	Register Name	D7	D6	D5	D4	D3	D2	D1	D0
0EH	Headphone ATT	0	HPZ	HMUTE	ATTH4	ATTH3	ATTH2	ATTH1	ATTH0
	R/W	RD	R/W	R/W	R/W	R/W	R/W	R/W	R/W
	Default	0	0	0	0	0	0	0	0

ATTH4-0: Setting of the attenuation value of output signal from Headphone (Table 15)

Default: HMUTE bit = "0", ATTH4-0 bits = "00" (0dB)

Setting of ATTH4-0 bits is enabled at HMUTE bit is "0".

HMUTE: Mute control for Headphone-Amp

0: Normal operation. ATTH4-0 bits control attenuation value. (Default)

1: Mute. ATTH4-0 bits are ignored.

HPZ: Headphone-Amp Pull-down Control

0: Shorted to GND (Default)

1: Pulled-down by 200kΩ (typ)

Addr	Register Name	D7	D6	D5	D4	D3	D2	D1	D0
0FH	Lineout Select	0	0	0	0	RIN2R	RIN2L	LIN1R	RIN1L
	R/W	RD	RD	RD	RD	R/W	R/W	R/W	R/W
	Default	0	0	0	0	0	0	0	0

RIN1L: RIN1 signal is added to the left channel of the Lineout

0: OFF (Default)

1: ON

LIN1R: LIN1 signal is added to the right channel of the Lineout

0: OFF (Default)

1: ON

RIN2L: RIN2 signal is added to the left channel of the Lineout

0: OFF (Default)

1: ON

RIN2R: RIN2 signal is added to the right channel of the Lineout

0: OFF (Default)

1: ON

Addr	Register Name	D7	D6	D5	D4	D3	D2	D1	D0
10H	Mono Mixing	0	0	0	0	L2M	L2HM	L1M	L1HM
	R/W	RD	RD	RD	RD	R/W	R/W	R/W	R/W
	Default	0	0	0	0	0	0	0	0

L1HM: LIN1/RIN1 signal is added to Headphone-Amp as (L+R)/2.

0: OFF (Default)

1: ON

L1M: LIN1/RIN1 signal is added to LOUT/ROUT as (L+R)/2.

0: OFF (Default)

1: ON

L2HM: LIN2/RIN2 signal is added to Headphone-Amp as (L+R)/2.

0: OFF (Default)

1: ON

L2M: LIN2/RIN2 signal is added to LOUT/ROUT as (L+R)/2.

0: OFF (Default)

1: ON

Addr	Register Name	D7	D6	D5	D4	D3	D2	D1	D0
11H	Differential Select	0	0	0	0	0	0	LDIFH	LDIF
	R/W	RD	RD	RD	RD	RD	RD	R/W	R/W
	Default	0	0	0	0	0	0	0	0

LDIF: Switch control from IN+/IN- pin to LOUT/ROUT.

0: OFF (Default)

1: ON

When LDIF bit = "1", LIN1 and RIN1 pins become IN+ and IN- pins respectively

LDIFH: Switch control from IN+/IN- pin to Headphone-Amp. (Setting of LDIFH bit is enable at LDIF bit = "1")

0: OFF (Default)

1: ON

SYSTEM DESIGN

Figure 38 shows the system connection diagram. An evaluation board [AKD4370] is available which demonstrates the optimum layout, power supply arrangements and measurement results.

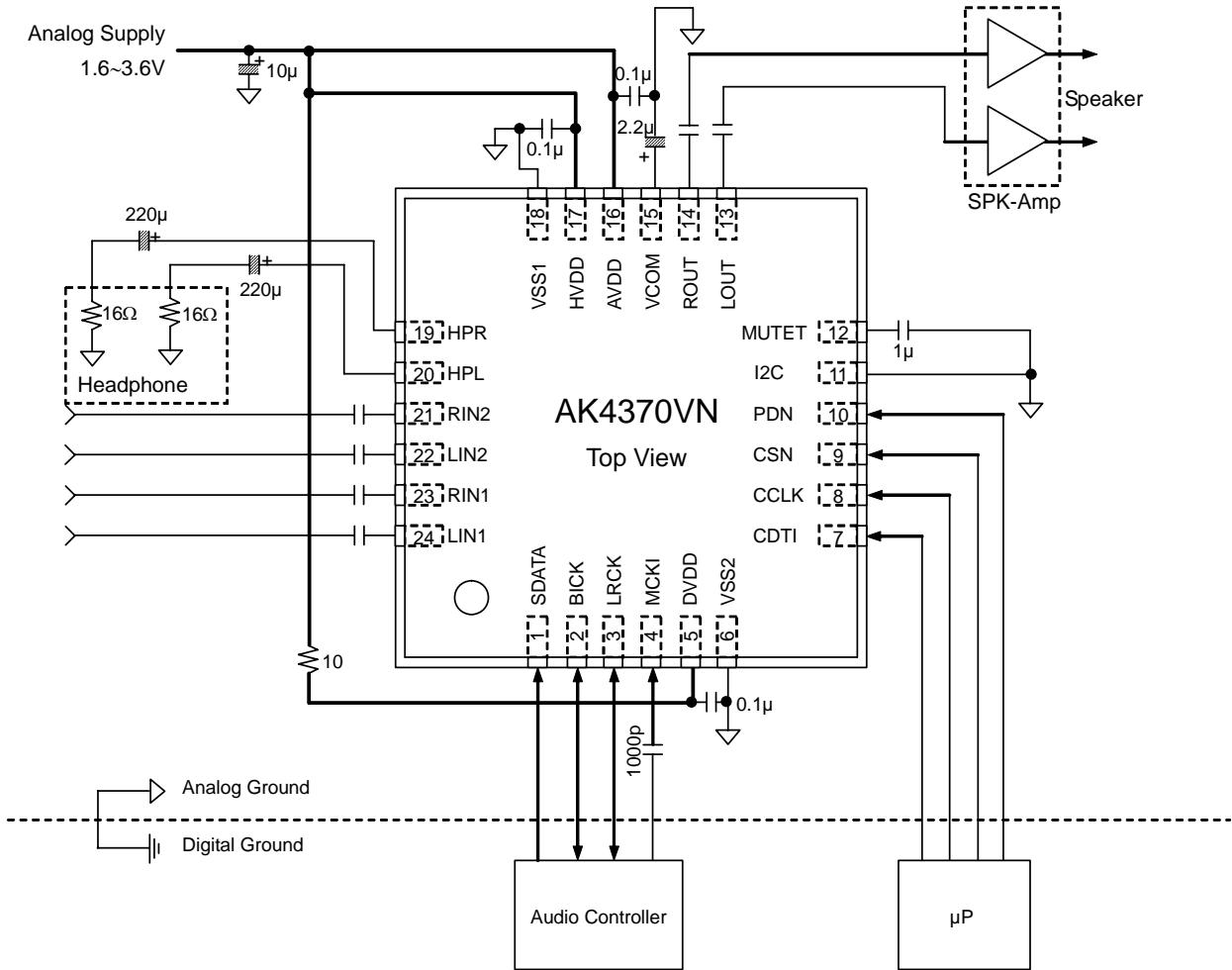

Notes:

- VSS1 and VSS2 of the AK4370 should be distributed separately from the ground of external controllers.
- All digital input pins (I2C, SDA/CDTI, SCL/CCLK, CAD0/CSN, SDATA, LRCK, BICK, MCKI, PDN) must not be left floating.
- When the AK4370 is used in master mode, LRCK and BICK pins are floating before the M/S bit is changed to "1". Therefore, a 100kΩ pull-up resistor should be connected to the LRCK and BICK pins of the AK4370.
- When DVDD is supplied from AVDD via 10Ω series resistor, the capacitor larger than 0.1µF should not be connected between DVDD and the ground.

Figure 38. Typical Connection Diagram (In case of AC coupling to MCKI)

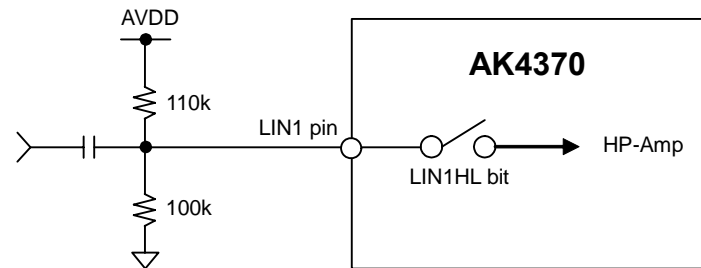

Note: If the path is OFF and the signal is input to the input pin, the input pin should be biased to a voltage equivalent to VCOM voltage ($= 0.475 \times AVDD$) externally.

Figure 39. External Bias Circuit Example for Line Input Pin

1. Grounding and Power Supply Decoupling

The AK4370 requires careful attention to power supply and grounding arrangements. AVDD and HVDD are usually supplied from the analog power supply in the system and DVDD is supplied from AVDD via a 10Ω resistor. Alternatively if AVDD and DVDD are supplied separately, AVDD should be powered-up after DVDD rises up to 1.6V or more. When the AK4370 is powered-down, DVDD should be powered-down at the same time or later than AVDD. When AVDD and HVDD are supplied separately, AVDD should be powered-up at the same time or earlier than HVDD. When the AK4370 is powered-down, AVDD should be powered-down at the same time or later than HVDD. VSS1 and VSS2 must be connected to the analog ground plane. System analog ground and digital ground should be connected together near to where the supplies are brought onto the printed circuit board. Decoupling capacitors should be as close to the AK4370 as possible, with the small value ceramic capacitors being the nearest.

2. Voltage Reference

The input voltage to AVDD sets the analog output range. Usually a $0.1\mu\text{F}$ ceramic capacitor is connected between AVDD and VSS1. VCOM is a signal ground of this chip ($0.475 \times AVDD$). The electrolytic capacitor around $2.2\mu\text{F}$ attached between VCOM and VSS1 eliminates the effects of high frequency noise, too. No load current may be drawn from VCOM pin. All signals, especially clock, should be kept away from AVDD and VCOM in order to avoid unwanted coupling into the AK4370.

3. Analog Outputs

The analog outputs are single-ended outputs, and $0.48 \times AVDD V_{pp}(\text{typ})@-3\text{dBFS}$ for headphone-amp and $0.61 \times AVDD V_{pp}(\text{typ}) @0\text{dBFS}$ for LOUT/ROUT centered on the VCOM voltage. The input data format is 2's complement. The output voltage is a positive full scale for 7FFFFFFH(@24bit) and negative full scale for 800000H(@24bit). The ideal output is VCOM voltage for 000000H(@24bit).

DC offsets on the analog outputs is eliminated by AC coupling since the analog outputs have a DC offset equal to VCOM plus a few mV.

PACKAGE

● 24pin QFN (Unit: mm)

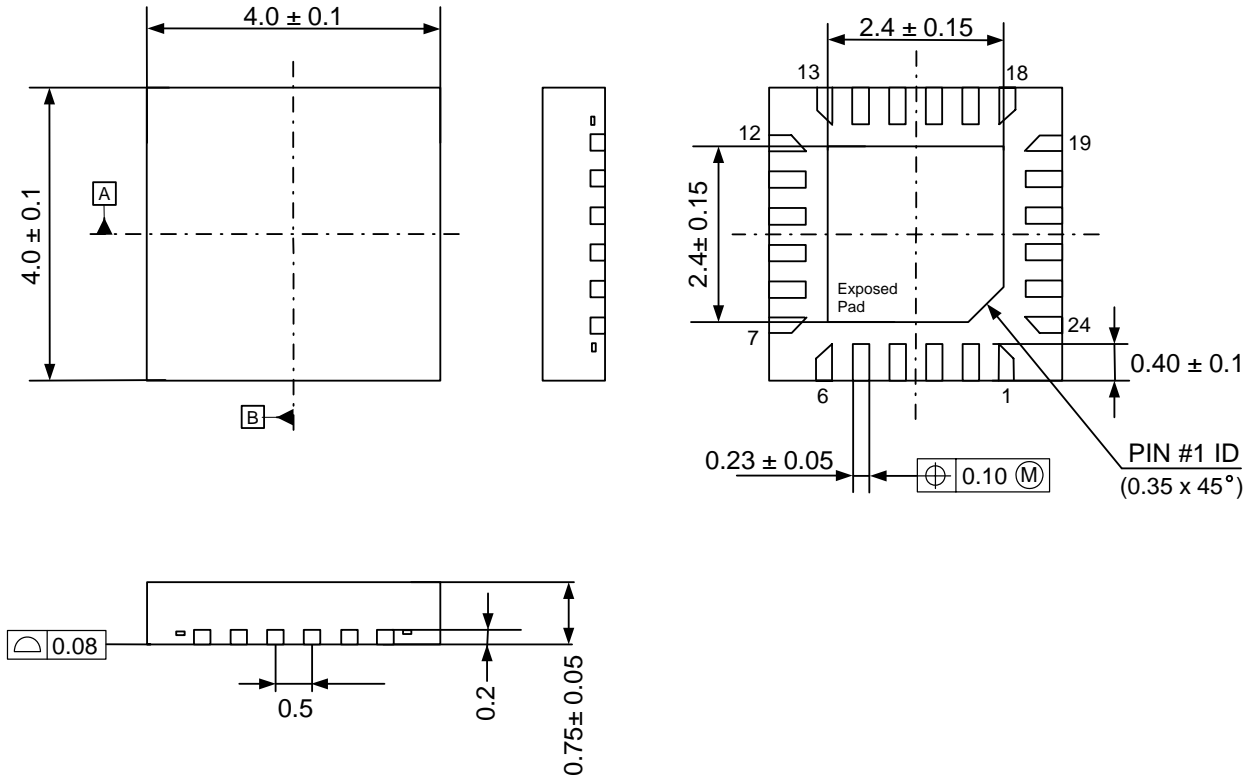

Note) The exposed pad on the bottom surface of the package must be open or connected to the ground.

■ Package & Lead frame material

- Package molding compound: Epoxy
- Lead frame material: Cu
- Lead frame surface treatment: Solder (Pb free) plate

MARKING

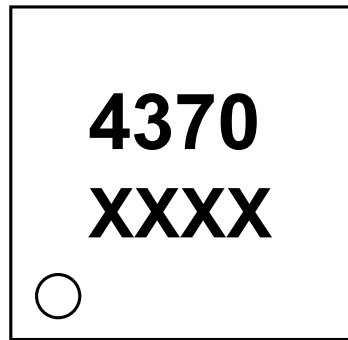

XXXX: Date code (4 digit)

Revision History

Date (YY/MM/DD)	Revision	Reason	Page	Contents
07/03/23	00	First Edition		

IMPORTANT NOTICE

- These products and their specifications are subject to change without notice. Before considering any use or application, consult the Asahi Kasei Microsystems Co., Ltd. (AKM) sales office or authorized distributor concerning their current status.
- AKM assumes no liability for infringement of any patent, intellectual property, or other right in the application or use of any information contained herein.
- Any export of these products, or devices or systems containing them, may require an export license or other official approval under the law and regulations of the country of export pertaining to customs and tariffs, currency exchange, or strategic materials.
- AKM products are neither intended nor authorized for use as critical components in any safety, life support, or other hazard related device or system, and AKM assumes no responsibility relating to any such use, except with the express written consent of the Representative Director of AKM. As used here:
 - a. A hazard related device or system is one designed or intended for life support or maintenance of safety or for applications in medicine, aerospace, nuclear energy, or other fields, in which its failure to function or perform may reasonably be expected to result in loss of life or in significant injury or damage to person or property.
 - b. A critical component is one whose failure to function or perform may reasonably be expected to result, whether directly or indirectly, in the loss of the safety or effectiveness of the device or system containing it, and which must therefore meet very high standards of performance and reliability.
- It is the responsibility of the buyer or distributor of an AKM product who distributes, disposes of, or otherwise places the product with a third party to notify that party in advance of the above content and conditions, and the buyer or distributor agrees to assume any and all responsibility and liability for and hold AKM harmless from any and all claims arising from the use of said product in the absence of such notification.