



110CNQ045APbF 110CNQ045ASMPbF

SCHOTTKY RECTIFIER
New GenIII D-61 Package

110 Amp

Major Ratings and Characteristics

Characteristics	Values	Units
$I_{F(AV)}$ Rectangular waveform	110	A
V_{RRM}	45	V
I_{FSM} @tp = 5 μ s sine	5400	A
V_F @55Apk, $T_J = 125^\circ\text{C}$ (per leg)	0.5	V
T_J range	-55 to 150	$^\circ\text{C}$

Description/ Features

The center tap Schottky rectifier module has been optimized for very low forward voltage drop, with moderate leakage. The proprietary barrier technology allows for reliable operation up to 150 $^\circ\text{C}$ junction temperature. Typical applications are in switching power supplies, converters, free-wheeling diodes, and reverse battery protection.

- 150 $^\circ\text{C}$ T_J operation
- Center tap module
- Very low forward voltage drop
- High purity, high temperature epoxy encapsulation for enhanced mechanical strength and moisture resistance
- High frequency operation
- Guard ring for enhanced ruggedness and long term reliability
- Low profile, small footprint, high current package
- ***New fully transfer-mold low profile, small footprint, high current package***
- Through-hole versions are currently available for use in Lead-Free applications ("PbF" suffix)

Case Styles

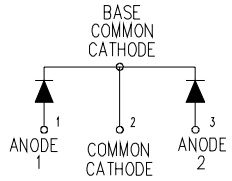
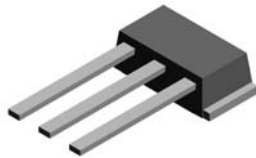
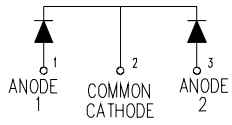
<p>110CNQ045APbF</p>   <p>D61-8</p>	<p>110CNQ045ASMPbF</p>   <p>D61-8-SM</p>
--	---

Voltage Ratings

Part number	110CNQ045A..
V_R Max. DC Reverse Voltage (V)	45
V_{RWM} Max. Working Peak Reverse Voltage (V)	

Absolute Maximum Ratings

Parameters	110CNQ	Units	Conditions
$I_{F(AV)}$ Max. Average Forward Per Leg Current * See Fig. 5 Per Device	55 110	A	50% duty cycle @ $T_C = 125^\circ\text{C}$, rectangular wave form
I_{FSM} Max. Peak One Cycle Non-Repetitive Surge Current (Per Leg) * See Fig. 7	5400 800	A	5 μs Sine or 3 μs Rect. pulse 10ms Sine or 6ms Rect. pulse Following any rated load condition and with rated V_{RWM} applied
E_{AS} Non-Repetitive Avalanche Energy (Per Leg)	54	mJ	$T_J = 25^\circ\text{C}$, $I_{AS} = 8$ Amps, $L = 1.7$ mH
I_{AR} Repetitive Avalanche Current (Per Leg)	8	A	Current decaying linearly to zero in 1 μsec Frequency limited by T_J max. $V_A = 1.5 \times V_R$ typical

Electrical Specifications

Parameters	110CNQ	Units	Conditions
V_{FM} Max. Forward Voltage Drop (Per Leg) * See Fig. 1 (1)	0.54	V	@ 55A $T_J = 25^\circ\text{C}$
	0.7	V	@ 110A $T_J = 25^\circ\text{C}$
	0.5	V	@ 55A $T_J = 125^\circ\text{C}$
	0.69	V	@ 110A $T_J = 125^\circ\text{C}$
I_{RM} Max. Reverse Leakage Current (Per Leg) * See Fig. 2 (1)	3	mA	$T_J = 25^\circ\text{C}$ $V_R = \text{rated } V_R$
	350	mA	$T_J = 125^\circ\text{C}$
C_T Max. Junction Capacitance (Per Leg)	3800	pF	$V_R = 5V_{DC}$ (test signal range 100Khz to 1Mhz) 25°C
L_S Typical Series Inductance (Per Leg)	5.5	nH	Measured lead to lead 5mm from package body
dv/dt Max. Voltage Rate of Change (Rated V_R)	10000	V/ μs	

(1) Pulse Width < 300 μs , Duty Cycle <2%

Thermal-Mechanical Specifications

Parameters	110CNQ	Units	Conditions
T_J Max. Junction Temperature Range	-55 to 150	$^\circ\text{C}$	
T_{stg} Max. Storage Temperature Range	-55 to 150	$^\circ\text{C}$	
R_{thJC} Max. Thermal Resistance Junction to Case (Per Leg)	0.5	$^\circ\text{C}/\text{W}$	DC operation * See Fig. 4
R_{thJC} Max. Thermal Resistance Junction to Case (Per Package)	0.25	$^\circ\text{C}/\text{W}$	DC operation
R_{thCS} Typical Thermal Resistance, Case to Heatsink (D61-8 Only)	0.30	$^\circ\text{C}/\text{W}$	Mounting surface, smooth and greased Device flatness < 5 mils
wt Approximate Weight	7.8 (0.28)	g (oz.)	
T Mounting Torque (D61-8 Only)	Min.	40 (35)	Kg-cm (lbf-in)
	Max.	58 (50)	

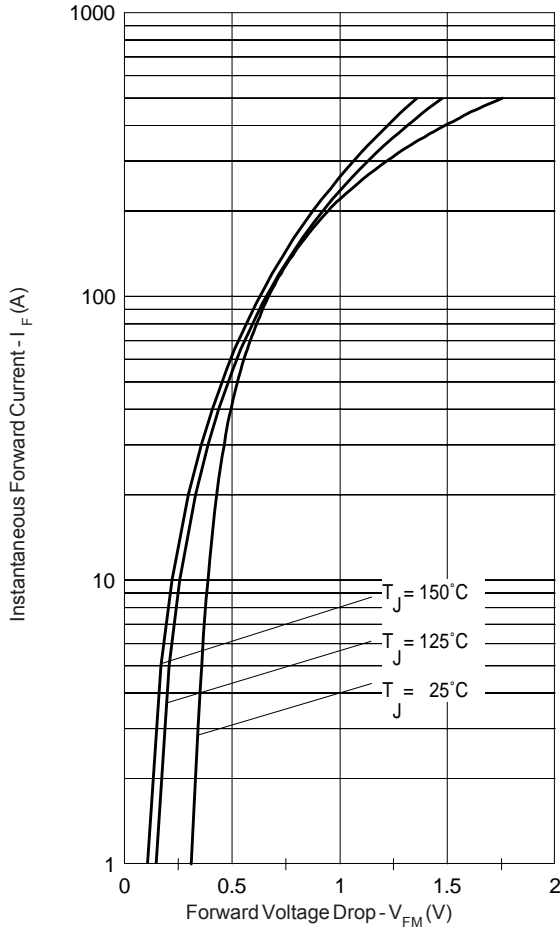

Fig. 1 - Max. Forward Voltage Drop Characteristics (Per Leg)

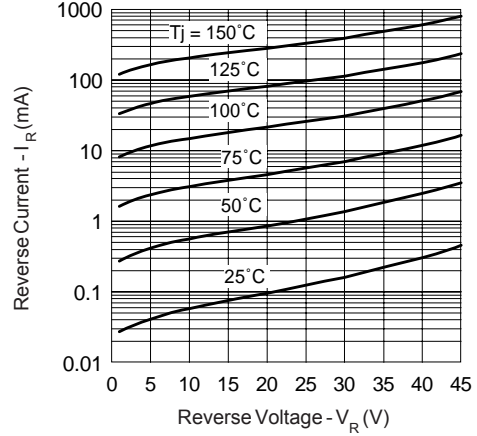

Fig. 2 - Typical Values Of Reverse Current Vs. Reverse Voltage (Per Leg)

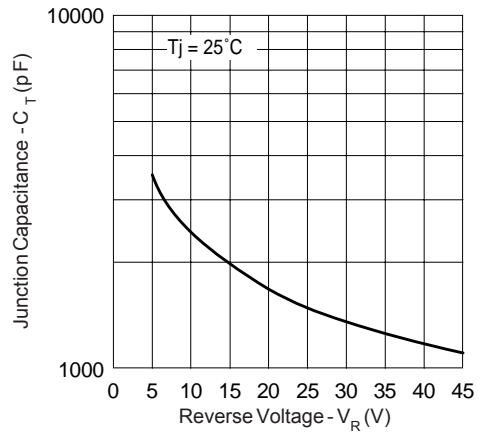

Fig. 3 - Typical Junction Capacitance Vs. Reverse Voltage (Per Leg)

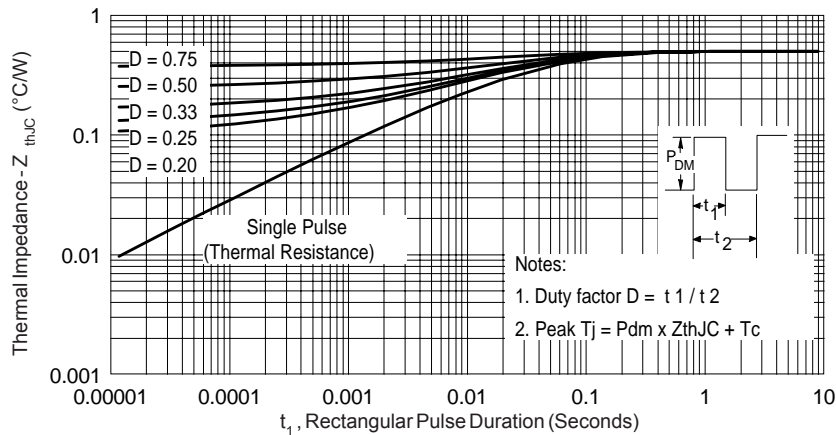

Fig. 4 - Max. Thermal Impedance Z_{thJC} Characteristics (Per Leg)

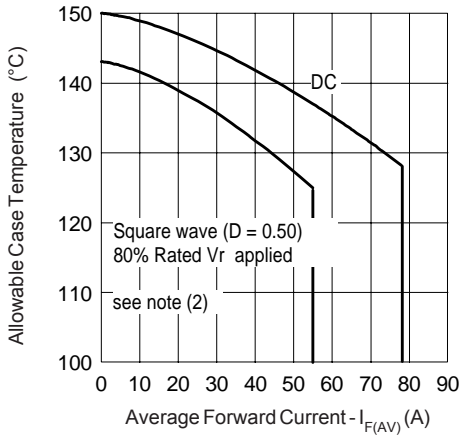

Fig. 5 - Max. Allowable Case Temperature Vs. Average Forward Current (Per Leg)

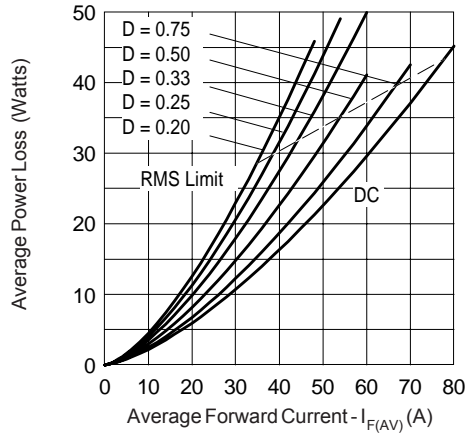

Fig. 6 - Forward Power Loss Characteristics (Per Leg)

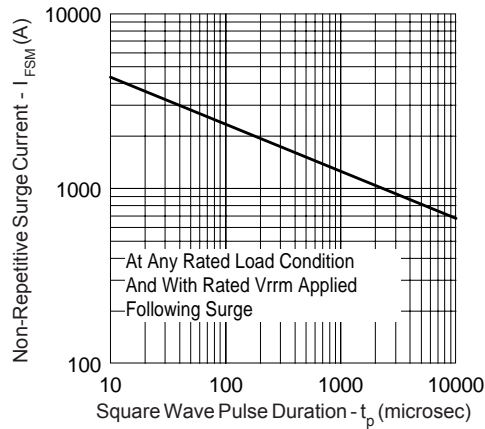

Fig. 7 - Max. Non-Repetitive Surge Current (Per Leg)

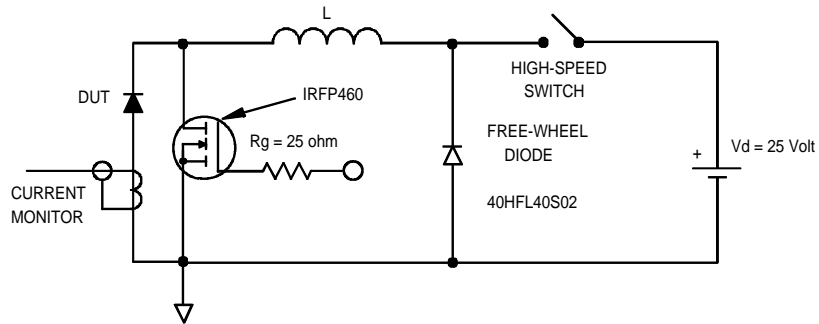

Fig. 8 - Unclamped Inductive Test Circuit

(2) Formula used: $T_c = T_j - (Pd + Pd_{REV}) \times R_{thJC}$;

Pd = Forward Power Loss = $I_{F(AV)} \times V_{FM} @ (I_{F(AV)} / D)$ (see Fig. 6);

Pd_{REV} = Inverse Power Loss = $V_{R1} \times I_R (1 - D)$; $I_R @ V_{R1} = 80\%$ rated V_R

Outline Table

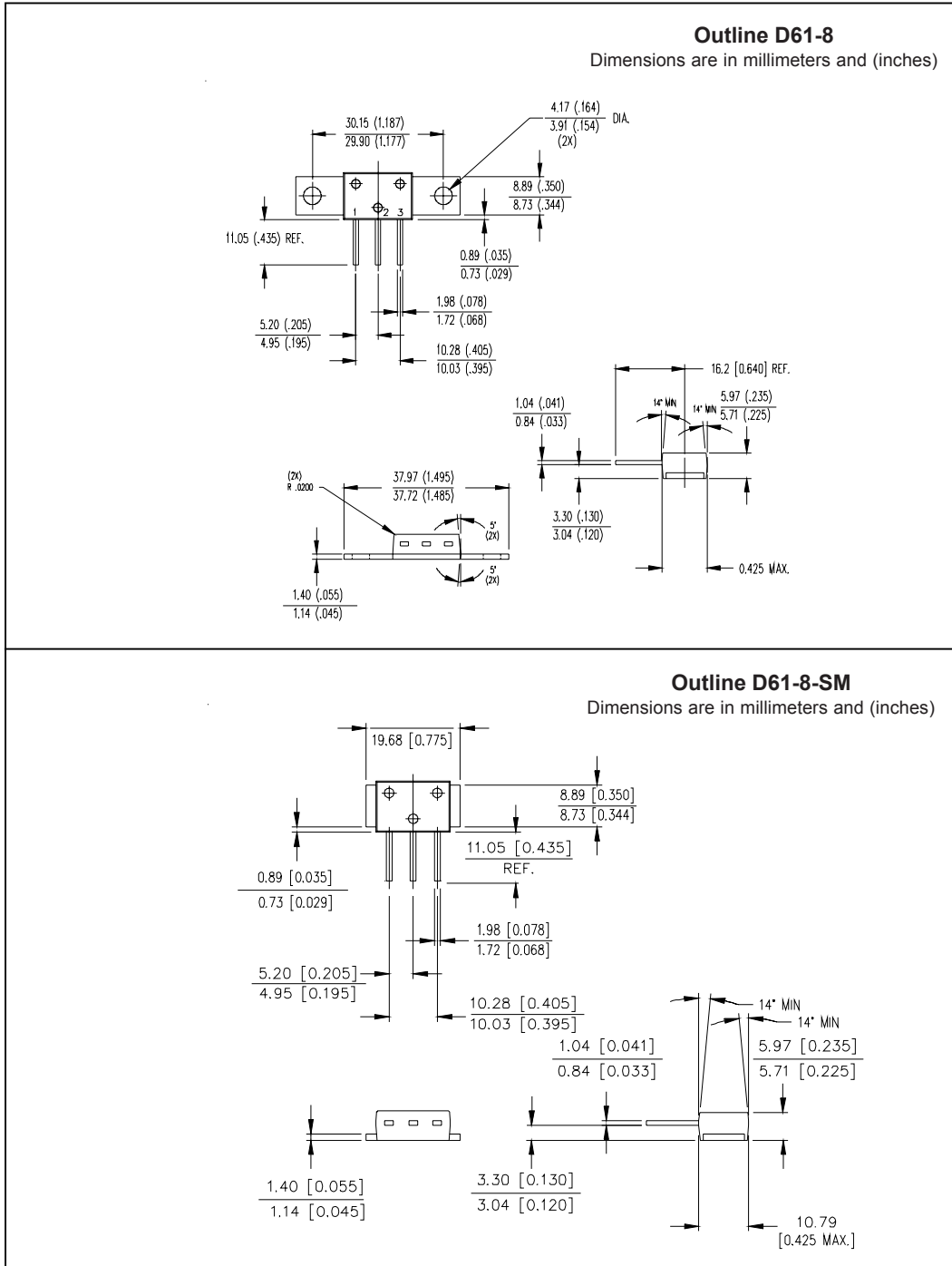

Outline D61-8-SM
 Dimensions are in millimeters and (inches)

Marking Information

Outline D61-8

EXAMPLE: THIS IS A 110CNQ045A WITH
 LOT CODE 89 09
 ASSEMBLED ON WW 45, 2000

Note: "P" in assembly line
 position indicates "Lead-Free"

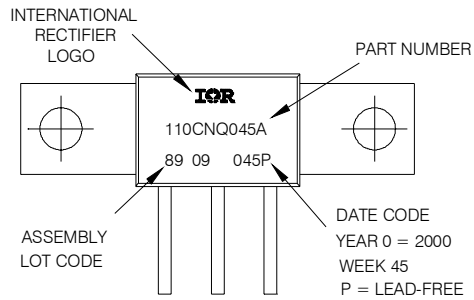

Outline D61-8-SM

EXAMPLE: THIS IS A 110CNQ045ASM WITH
 LOT CODE 89 09
 ASSEMBLED ON WW 45, 2000

Note: "P" in assembly line
 position indicates "Lead-Free"

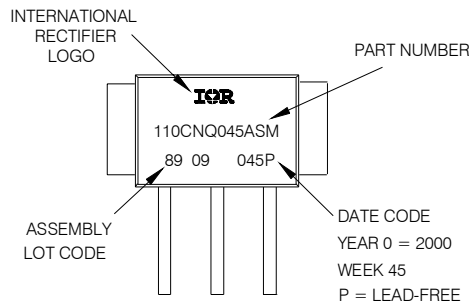

Ordering Information Table

Device Code	
110	C
N	Q
045	A
PbF	
(1)	(2)
(3)	(4)
(5)	(6)
(7)	

1	-	Current Rating (110 = 110A)
2	-	Circuit Configuration C = Common Cathode
3	-	Package N = D-61
4	-	Schottky "Q" Series
5	-	Voltage Rating (045 = 45V)
6	-	<ul style="list-style-type: none"> • A = D-61-8 package style • ASM = D-61-8-SM package style
7	-	<ul style="list-style-type: none"> • none = Standard Production • PbF = Lead-Free

Standard pack quantity: A = 10 pieces
 ASM = 20 pieces

Data and specifications subject to change without notice.
 This product has been designed and qualified for Industrial Level and Lead-Free.
 Qualification Standards can be found on IR's Web site.