

TOSHIBA Photointerrupter Infrared LED + Phototransistor

TLP832(F)

Lead(Pb)-Free

Electronic Equipment Such As VCRS
And CD PlayersOffice Equipment Such As Copiers,
Printers And Fax Machines

Automatic Vending Machines

Various Position Detection Sensors

The TLP832(F) photointerrupter consists of a GaAs infrared LED and an Si phototransistor. Housed in a short-lead package, this device is ideal for automatic mounting.

- Designed for direct mounting on printed circuit boards (positioning pins included).
- Short leads enabling automatic mounting
: Lead length $3.4\text{mm} \pm 0.3\text{mm}$
- Board thickness: 1.6mm or less
- Gap: 5mm
- Resolution: Slit width = 0.5mm
- High current transfer ratio: $I_C/I_F = 5\%$ (min)
- High temperature operation: $T_{opr} = 95^\circ\text{C}$ (max)
- High response speed: $t_r, t_f = 15\mu\text{s}$ (typ.)
- Detector impermeable to visible light
- package material: Polybutylene terephthalate (UL94V-0, black)

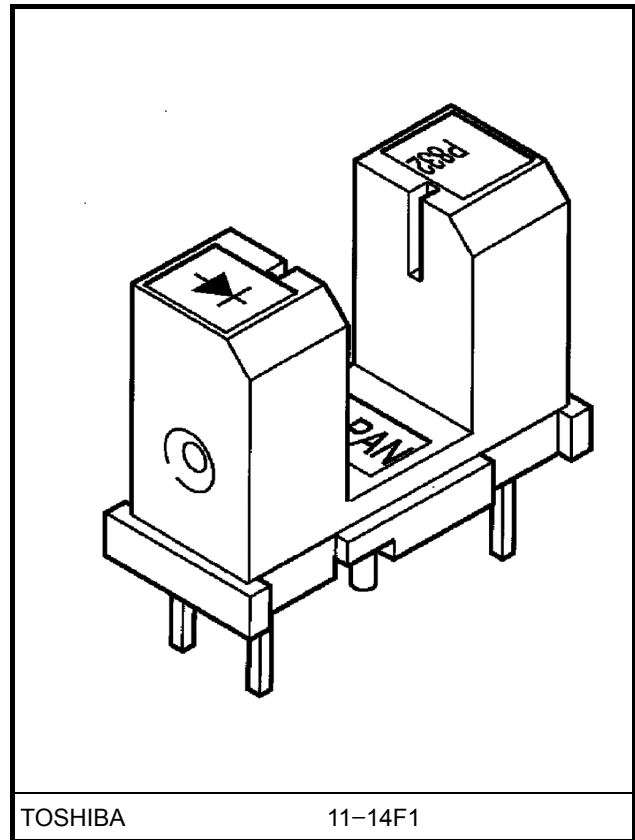

Weight: 0.58 g (typ.)

Absolute Maximum Ratings (Ta = 25°C)

Characteristic		Symbol	Rating	Unit
LED	Forward current	I_F	50	mA
	Forward current derating	$\Delta I_F / ^\circ\text{C}$	$25^\circ\text{C} < T_a \leq 85^\circ\text{C}$	-0.33
			$T_a > 85^\circ\text{C}$	-2
Reverse voltage		V_R	5	V
Detector	Collector-emitter voltage	V_{CEO}	35	V
	Emitter-collector voltage	V_{ECO}	5	V
	Collector power dissipation	P_C	75	mW
	Collector power dissipation derating (Ta > 25°C)	$\Delta P_C / ^\circ\text{C}$	-1	mW / °C
	Collector current	I_C	50	mA
Operating temperature		T_{opr}	-30~85	°C
Storage temperature		T_{stg}	-40~100	°C
Soldering temperature (5 s) (Note 1)		T_{sol}	260	°C

Note: Using continuously under heavy loads (e.g. the application of high temperature/current/voltage and the significant change in temperature, etc.) may cause this product to decrease in the reliability significantly even if the operating conditions (i.e. operating temperature/current/voltage, etc.) are within the absolute maximum ratings and the operating ranges.

Please design the appropriate reliability upon reviewing the Toshiba Semiconductor Reliability Handbook ("Handling Precautions"/"Derating Concept and Methods") and individual reliability data (i.e. reliability test report and estimated failure rate, etc).

Note 1: At the location of 1.5mm from the resin package bottom

Markings

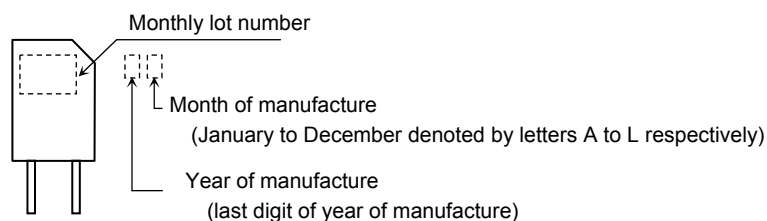

Operating Ranges

Characteristic	Symbol	Min	Typ.	Max	Unit
Supply voltage	V_{CC}	—	5	24	V
Forward current	I_F	—	—	25	mA
Operating temperature	T_{opr}	-10	—	75	°C

Optical And Electrical Characteristics (Ta = 25°C)

Characteristic		Symbol	Test Condition	Min	Typ.	Max	Unit
LED	Forward voltage	V_F	$I_F = 10\text{mA}$	1.00	1.15	1.30	V
	Reverse current	I_R	$V_R = 5\text{V}$	—	—	10	μA
	Peak emission wavelength	λ_P	$I_F = 10\text{mA}$	—	940	—	nm
Detector	Dark current	$I_D (I_{CEO})$	$V_{CE} = 24\text{V}, I_F = 0$	—	—	0.1	μA
	Peak sensitivity wavelength	λ_P		—	870	—	nm
Coupled	Current transfer ratio	I_C / I_F	$V_{CE} = 2\text{V}, I_F = 10\text{mA}$	5	—	100	%
	Collector-emitter saturation voltage	$V_{CE}(\text{sat})$	$I_F = 20\text{mA}, I_C = 0.5\text{mA}$	—	0.1	0.35	V
	Rise time	t_r	$V_{CC} = 5\text{V}, I_C = 1\text{mA}, R_L = 1\text{k}\Omega$ (Note 2)	—	15	50	μs
	Fall time	t_f		—	15	50	

(Note 2): Switching time measurement circuit and waveform

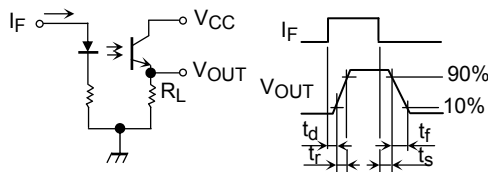

Precautions

- When removing flux with chemicals after soldering, clean only the soldered part of the leads. Do not immerse the entire package in the cleaning solvent. Chemical residue on the LED emitter or the phototransistor may adversely affect the optical characteristics of the device and may drastically reduce the conversion efficiency.
- Care must taken in relation to the environment in which the device is to be installed. Oil or chemicals may cause the package to melt or crack.
- Mount the device on a level surface.
- Keep the device away from external light. Although the phototransistor is of low optical sensitivity, the device may malfunction if external light with a wavelength of 700 nm or more is allowed to impinge on it.
- Conversion efficiency falls over time due to the current which flows in the infrared LED. When designing a circuit, take into account this change in conversion efficiency over time. The ratio of fluctuation in conversion efficiency to fluctuation in infrared LED optical output is 1:1.

$$\frac{I_C / I_F(t)}{I_C / I_F(0)} = \frac{P_O(t)}{P_O(0)}$$

Package Dimensions

11-14F1

Unit: mm

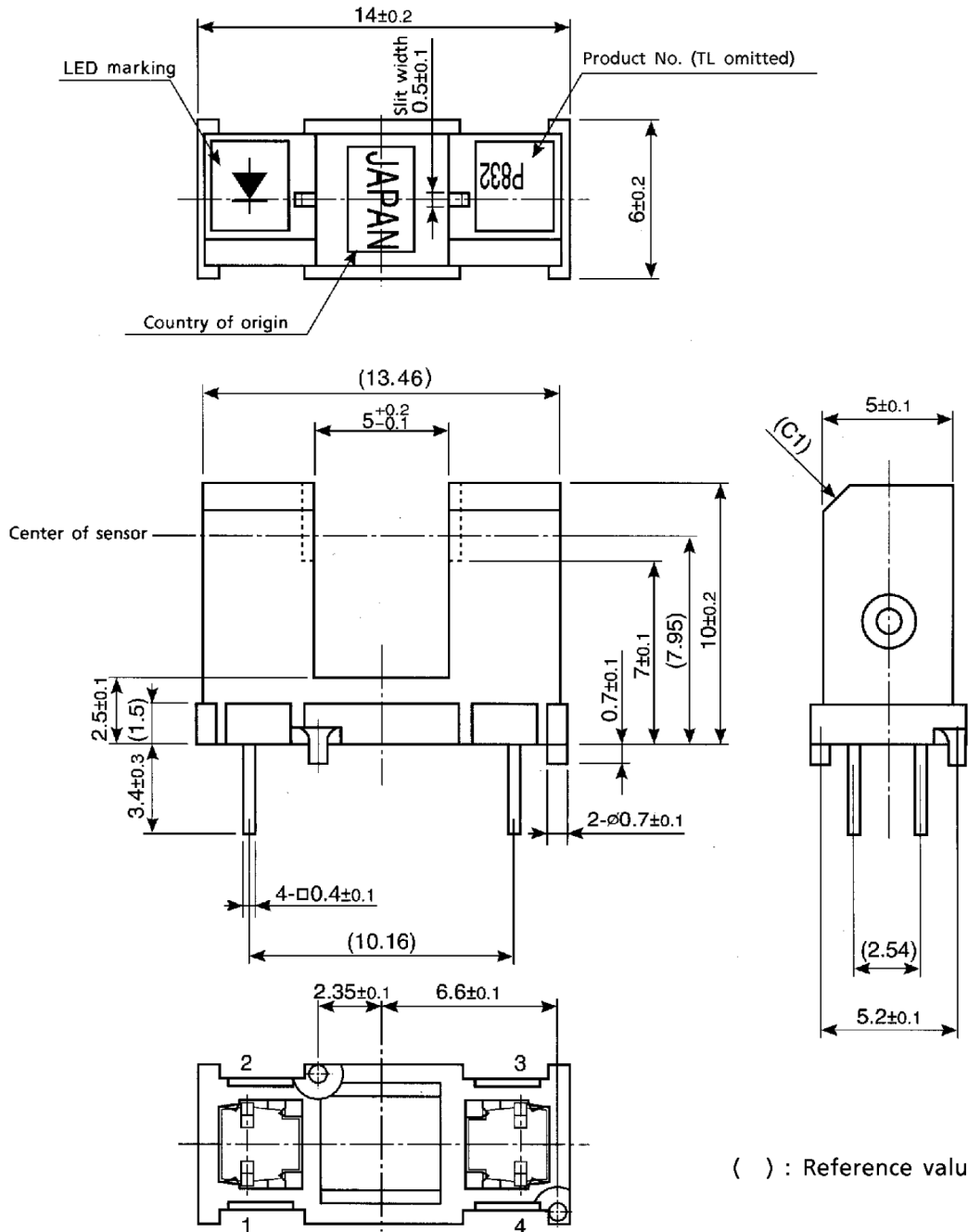

Weight: 0.58 g (typ.)

Pin Connection

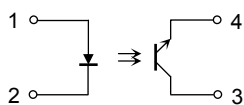

- 1. Anode
- 2. Cathode
- 3. Collector
- 4. Emitter

Stick Specification Of TLP832(F)

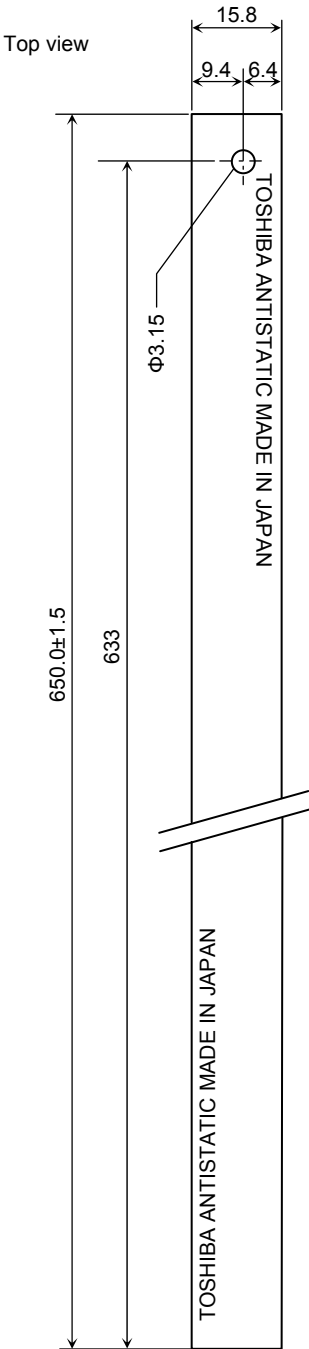

Unit:mm
Unless otherwise specified, tolerance:±0.3mm
Material:Polyvinyl chloride (PVC)

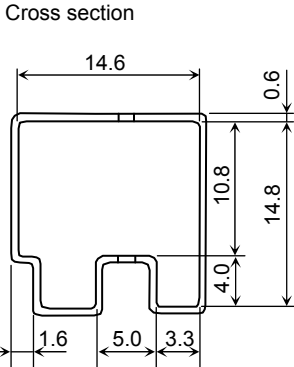

(note) : Marking color is red.

OPacking Format

Pack 100 devices are packed in a magazine and put it in a carton.
The carton contains 20 magazines.

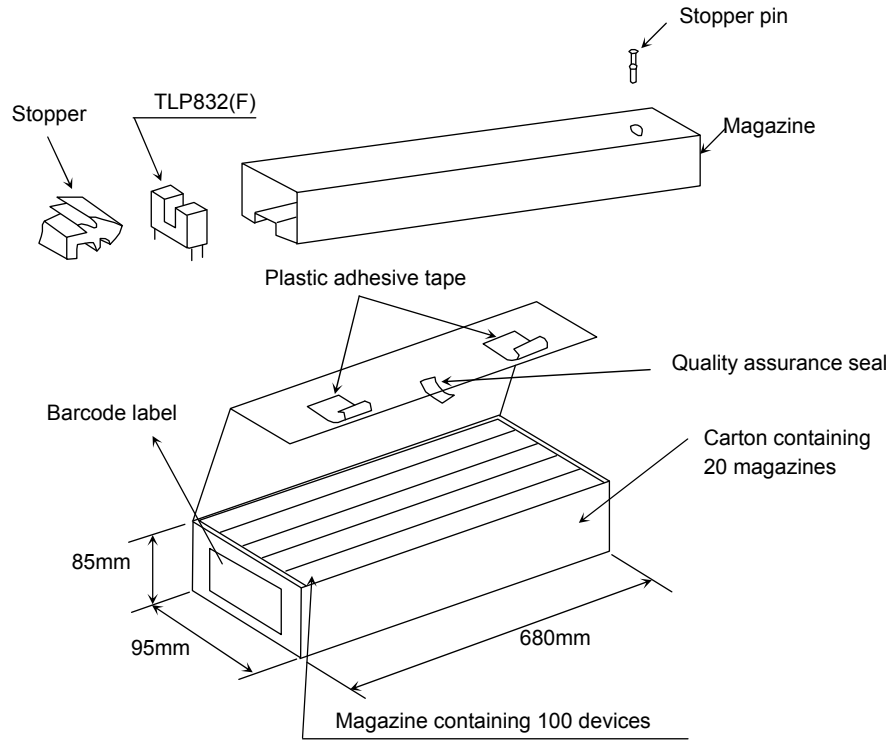

OLabel

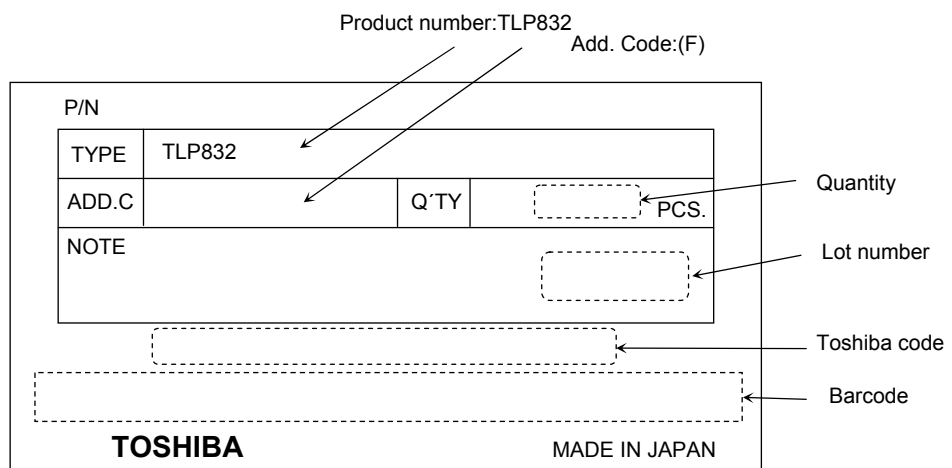

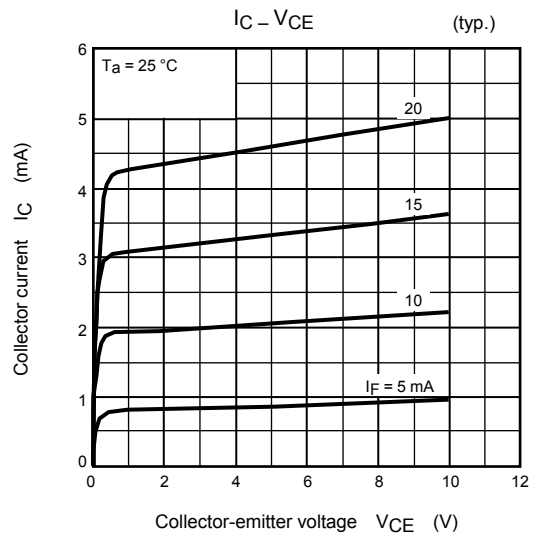
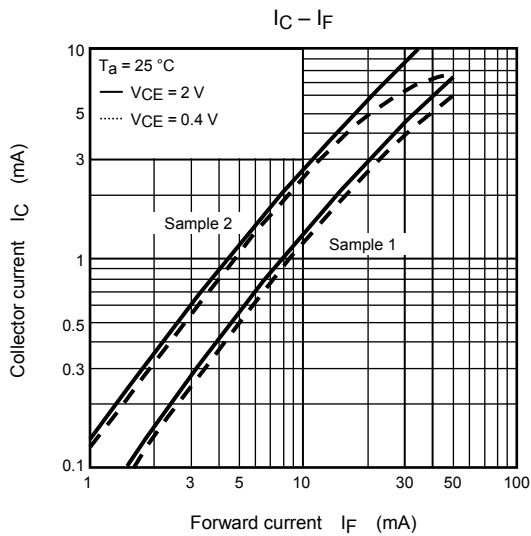
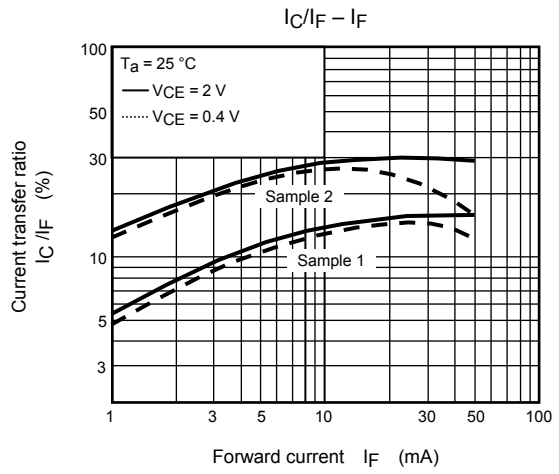
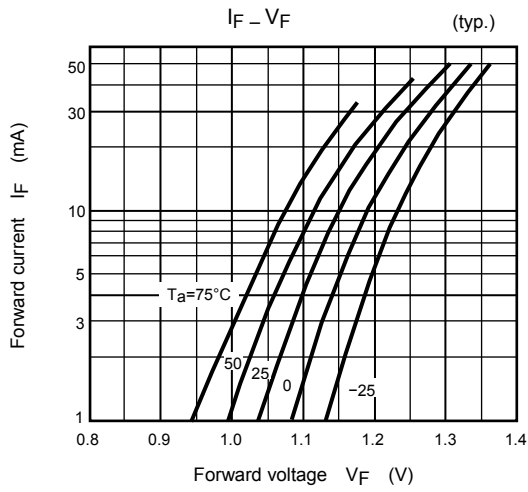
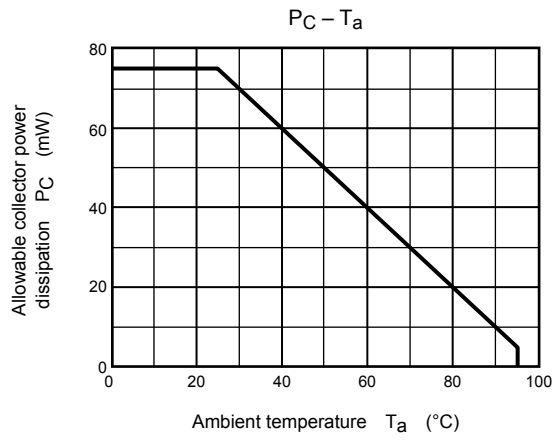
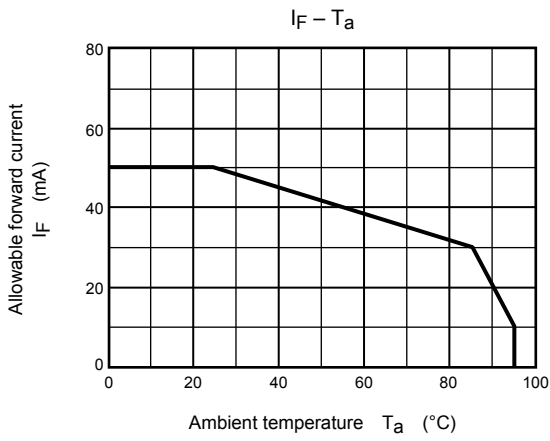

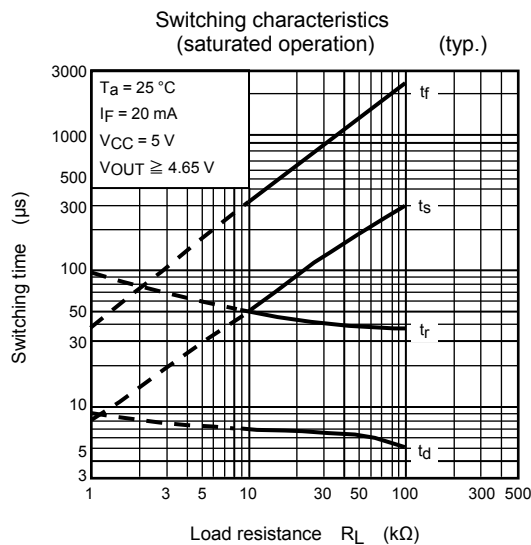
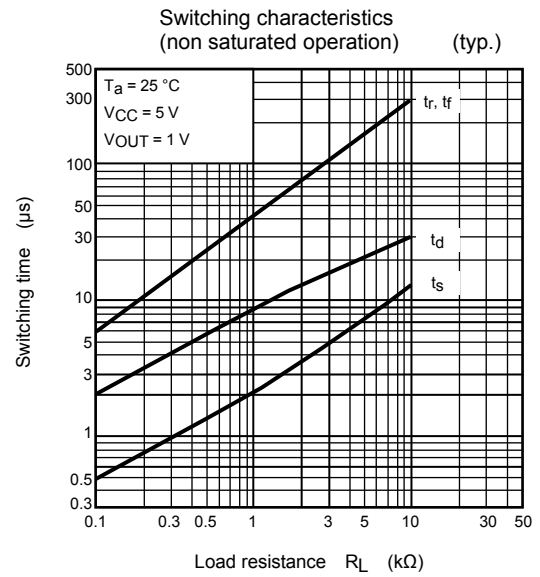
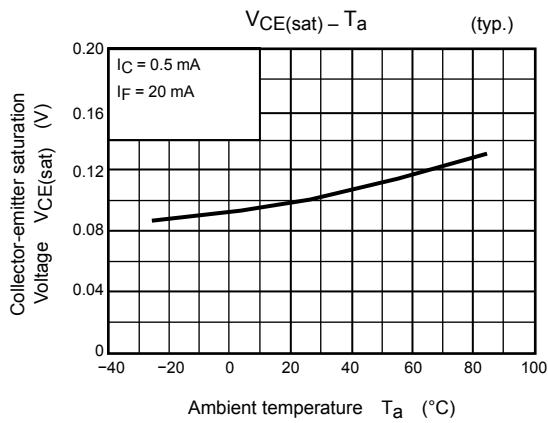
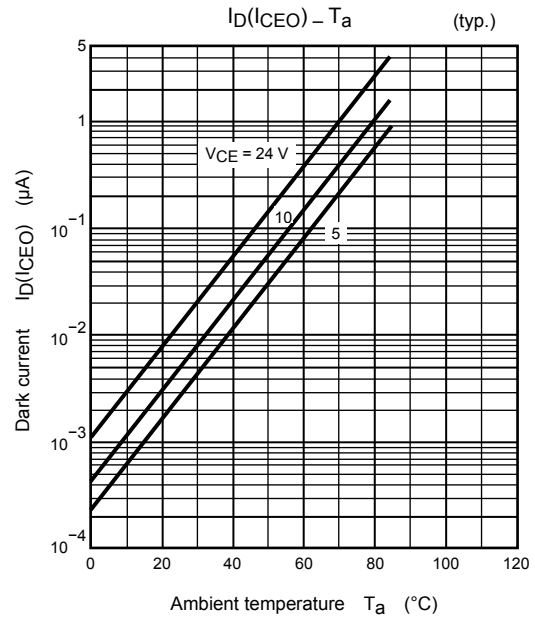
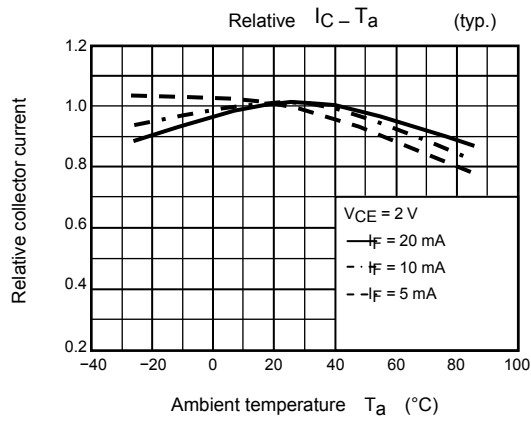

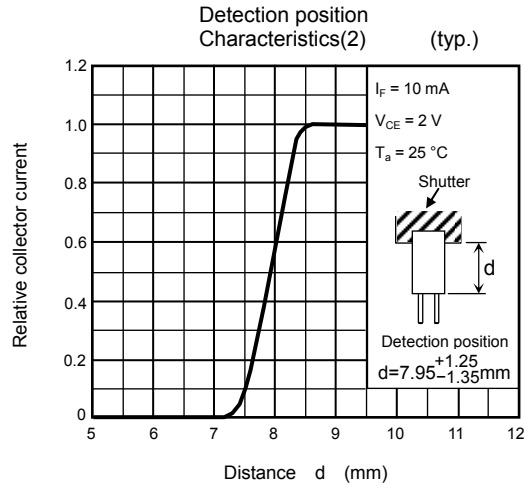
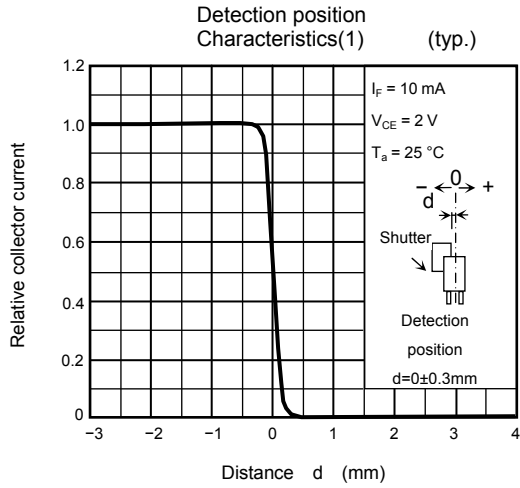

Relative Positioning Of Shutter And Device

For normal operation position the shutter and the device as shown in the figure below. By considering the device's detection direction characteristic and switching time, determine the shutter slit width and pitch.

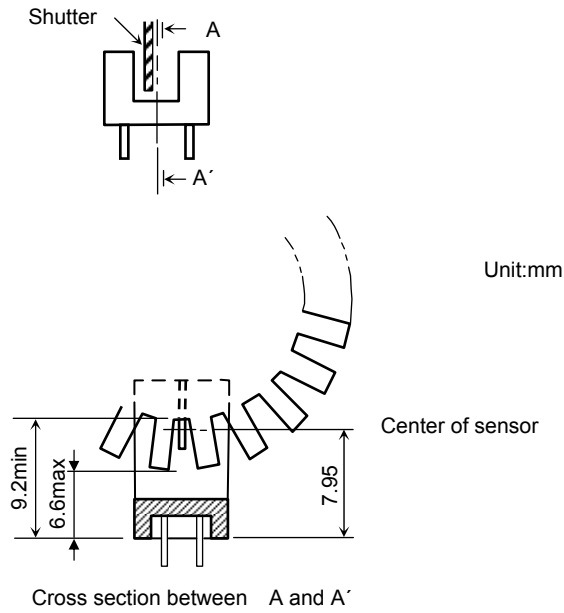

RESTRICTIONS ON PRODUCT USE

20070701-EN

- The information contained herein is subject to change without notice.
- TOSHIBA is continually working to improve the quality and reliability of its products. Nevertheless, semiconductor devices in general can malfunction or fail due to their inherent electrical sensitivity and vulnerability to physical stress. It is the responsibility of the buyer, when utilizing TOSHIBA products, to comply with the standards of safety in making a safe design for the entire system, and to avoid situations in which a malfunction or failure of such TOSHIBA products could cause loss of human life, bodily injury or damage to property.
In developing your designs, please ensure that TOSHIBA products are used within specified operating ranges as set forth in the most recent TOSHIBA products specifications. Also, please keep in mind the precautions and conditions set forth in the "Handling Guide for Semiconductor Devices," or "TOSHIBA Semiconductor Reliability Handbook" etc.
- The TOSHIBA products listed in this document are intended for usage in general electronics applications (computer, personal equipment, office equipment, measuring equipment, industrial robotics, domestic appliances, etc.). These TOSHIBA products are neither intended nor warranted for usage in equipment that requires extraordinarily high quality and/or reliability or a malfunction or failure of which may cause loss of human life or bodily injury ("Unintended Usage"). Unintended Usage include atomic energy control instruments, airplane or spaceship instruments, transportation instruments, traffic signal instruments, combustion control instruments, medical instruments, all types of safety devices, etc.. Unintended Usage of TOSHIBA products listed in this document shall be made at the customer's own risk.
- The products described in this document shall not be used or embedded to any downstream products of which manufacture, use and/or sale are prohibited under any applicable laws and regulations.
- The information contained herein is presented only as a guide for the applications of our products. No responsibility is assumed by TOSHIBA for any infringements of patents or other rights of the third parties which may result from its use. No license is granted by implication or otherwise under any patents or other rights of TOSHIBA or the third parties.
- GaAs(Gallium Arsenide) is used in this product. The dust or vapor is harmful to the human body. Do not break, cut, crush or dissolve chemically.
- Please contact your sales representative for product-by-product details in this document regarding RoHS compatibility. Please use these products in this document in compliance with all applicable laws and regulations that regulate the inclusion or use of controlled substances. Toshiba assumes no liability for damage or losses occurring as a result of noncompliance with applicable laws and regulations.