

High Voltage, Low Quiescent, 60mA LDO Regulator

General Description

The RT9022 is designed for positive CCD bias applications with critical performance and space requirements. The RT9022 performance is optimized for battery-powered systems to deliver low noise and low quiescent current and with soft start function.

The RT9022 also works well with low-ESR ceramic capacitors, reducing the amount of board space necessary for power applications and consumes less than 1µA in shutdown mode.

The other features include ultra low dropout voltage, high output accuracy, and current limiting protection. The part is available in the SOT-23-6, TSOT-23-6 and SC-70-6 packages.

Ordering Information

RT9022□□

Package Type

E : SOT-23-6

J6 : TSOT-23-6

U6 : SC-70-6

Operating Temperature Range

P : Pb Free with Commercial Standard

G : Green (Halogen Free with Commercial Standard)

Note :

Richtek Pb-free and Green products are :

- ▶RoHS compliant and compatible with the current requirements of IPC/JEDEC J-STD-020.
- ▶Suitable for use in SnPb or Pb-free soldering processes.
- ▶100% matte tin (Sn) plating.

Marking Information

For marking information, contact our sales representative directly or through a Richtek distributor located in your area, otherwise visit our website for detail.

Features

- Low Quiescent Current (Typically 40µA)
- Wide Operating Voltage Ranges : 5V to 20V
- Ultra-Fast Transient Response
- Tight Load and Line Regulation
- Current Limiting Protection
- Thermal Shutdown Protection
- Adjustable Soft Start Time
- RoHS Compliant and 100% Lead (Pb)-Free

Applications

- DSC
- Camcorder

Pin Configurations

(TOP VIEW)

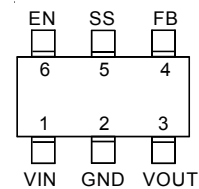

SOT-23-6 / TSOT-23-6 / SC-70-6

Note : There is no pin1 indicator on top mark for SOT-23-6 and SC-70-6 type, and pin 1 will be lower left pin when reading top mark from left to right.

Typical Application Circuit

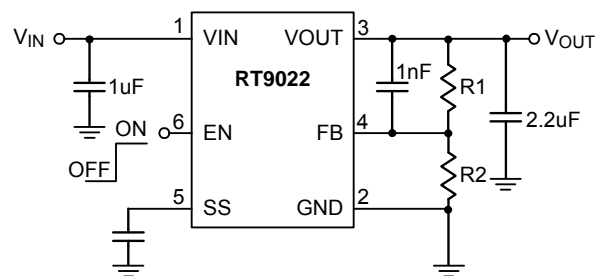

$$V_{OUT} = V_{FB} \left(1 + \frac{R1}{R2}\right) V$$

Absolute Maximum Ratings (Note 1)

- Supply Input Voltage, V_{IN} ----- 21V
- Enable Voltage, V_{EN} ----- 18V
- Power Dissipation, $P_D @ T_A = 25^\circ C$
 - SOT-23-6/TSOT-23-6 ----- 300mW
 - SC-70-6 ----- 225mW
- Package Thermal Resistance (Note 4)
 - SOT-23-6/TSOT-23-6, θ_{JA} ----- 250°C/W
 - SC-70-6, θ_{JA} ----- 333°C/W
- Lead Temperature (Soldering, 10 sec.) ----- 260°C
- Junction Temperature ----- 150°C
- Storage Temperature Range ----- -65°C to 150°C
- ESD Susceptibility (Note 2)
 - HBM (Human Body Mode) ----- 2kV
 - MM (Machine Mode) ----- 200V

Recommended Operating Conditions (Note 3)

- Supply Input Voltage, V_{IN} ----- 5V to 20V
- Junction Temperature Range ----- -40°C to 100°C
- Ambient Temperature Range ----- -40°C to 85°C

Electrical Characteristics

($V_{IN} = V_{EN} = 15V$, $C_{IN} = 1\mu F$, $C_{OUT} = 2.2\mu F$, $T_A = 25^\circ C$, unless otherwise specified)

Parameter	Symbol	Test Conditions	Min	Typ	Max	Units
Input Power						
Quiescent Current		$I_{OUT} = 0mA$	--	40	80	μA
Standby Current		EN = GND	--	--	1	μA
Reference Voltage						
Feedback Voltage		$V_{FB} = V_{OUT}$, $I_{LOAD} = 1mA$	--	1.25	--	V
Feedback Voltage Tolerance			-1.5	--	+1.5	%
Feedback Input Current		$V_{FB} = 1.3V$	--	10	--	nA
Soft Start						
Soft Start Current			--	1.5	--	μA
Output						
Output Current Limit	I_{LIM}	$V_{IN} = 15V$, $V_{OUT} = 14V$, $R_{OUT} = 50\Omega$	60	80	--	mA
Output Reverse Leakage Current		$V_{IN} = \text{Unconnected}$, Output set to 5V	--	30	--	μA
Dropout Voltage		$I_{LOAD} = 30mA$, $V_{OUT} = 14V$	--	0.2	0.3	V
Power Supply Rejection Rate		$f = 120Hz$, $V_{IN} = V_{OUT} + 1V$, $I_{OUT} = 10mA$	--	65	--	dB
		$f = 10KHz$, $V_{IN} = V_{OUT} + 1V$, $I_{OUT} = 10mA$	--	55	--	dB
Discharge Current		EN = High to Low, $V_{OUT} = 14V$	--	20	--	mA

To be continued

Parameter	Symbol	Test Conditions	Min	Typ	Max	Units
EN						
EN Input Current		EN = 15V	-1	--	3	μA
EN High-Level Input Voltage	V_{EN_H}		2.4	--	--	V
EN Low-Level Input Voltage	V_{EN_L}		--	--	0.6	V
Thermal Protection						
Thermal Shutdown Temperature			--	135	--	°C
Thermal Shutdown Hysteresis			--	10	--	°C

Note 1. Stresses listed as the above "Absolute Maximum Ratings" may cause permanent damage to the device. These are for stress ratings. Functional operation of the device at these or any other conditions beyond those indicated in the operational sections of the specifications is not implied. Exposure to absolute maximum rating conditions for extended periods may remain possibility to affect device reliability.

Note 2. Devices are ESD sensitive. Handling precaution recommended.

Note 3. The device is not guaranteed to function outside its operating conditions.

Note 4. θ_{JA} is measured in the natural convection at $T_A = 25^\circ\text{C}$ on a low effective thermal conductivity test board (single-layer, 1S) of JEDEC 51-3 thermal measurement standard.

Typical Operating Characteristics

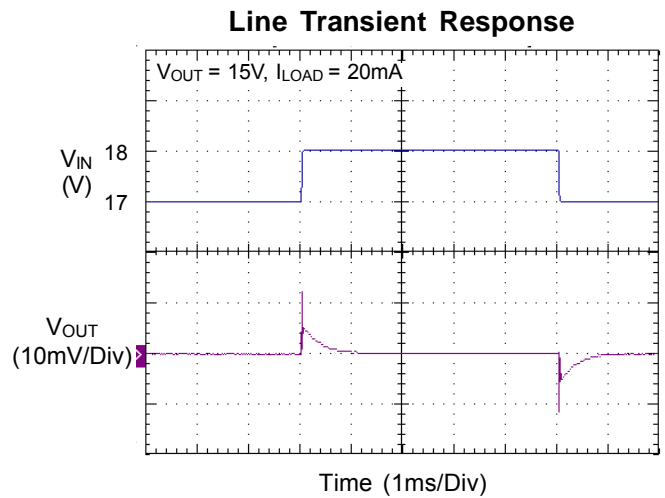
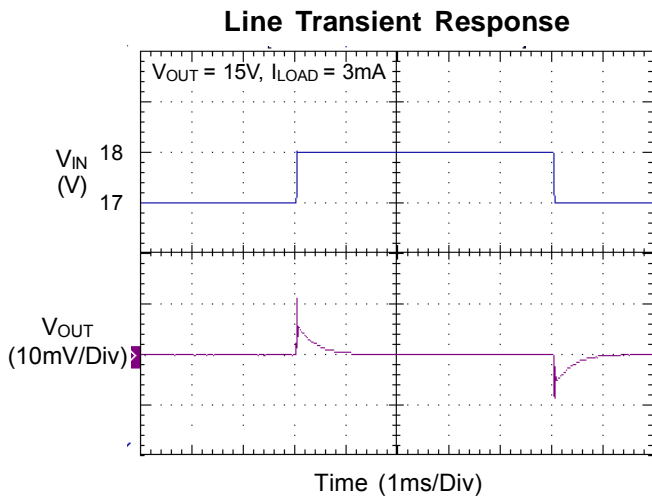
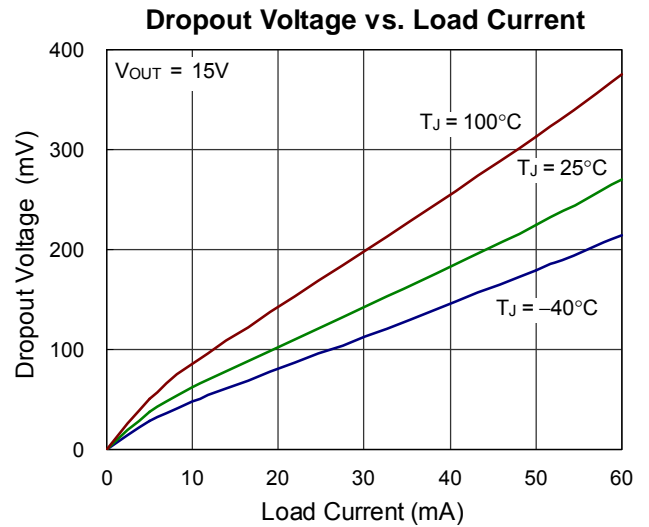
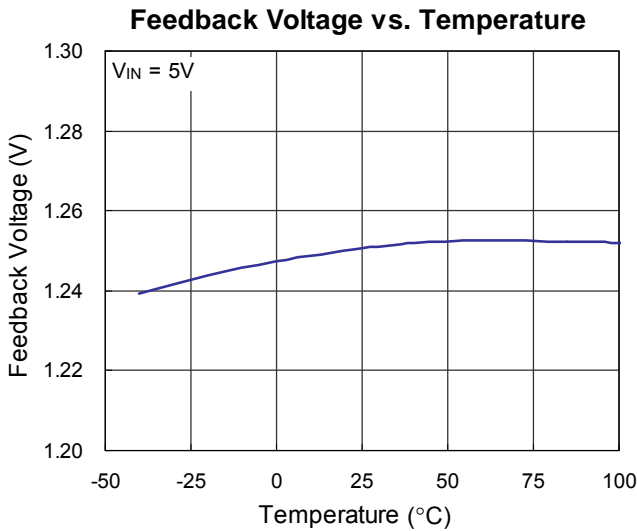
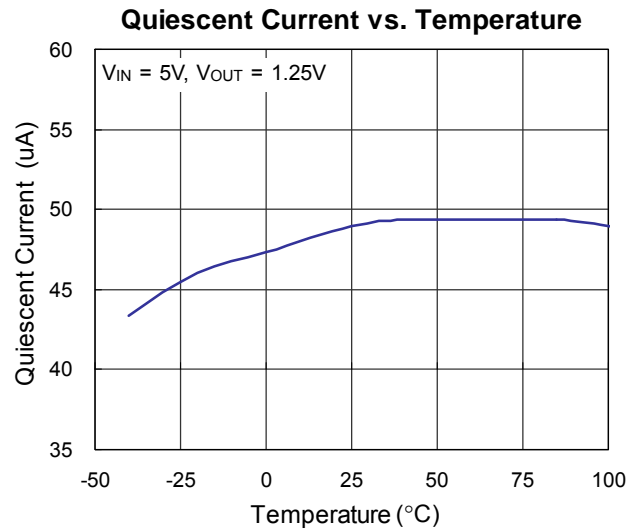
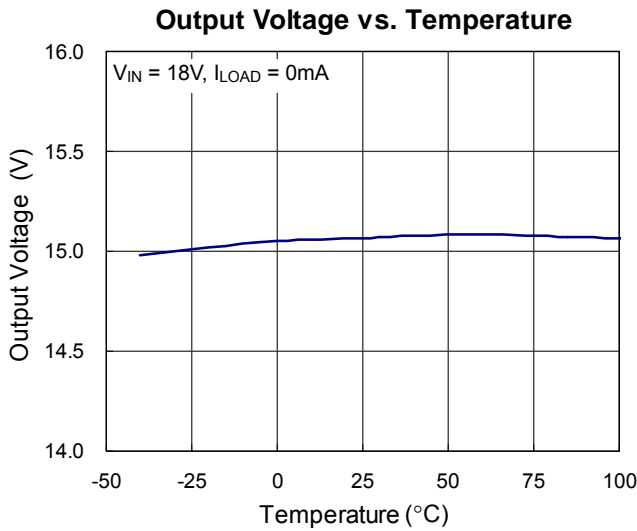

Load Transient Response

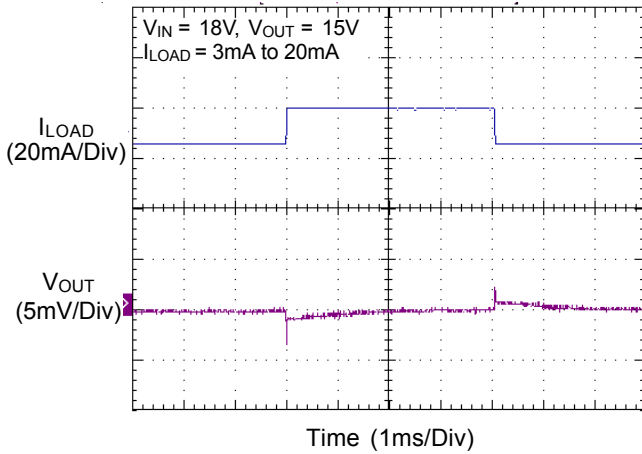

Load Transient Response

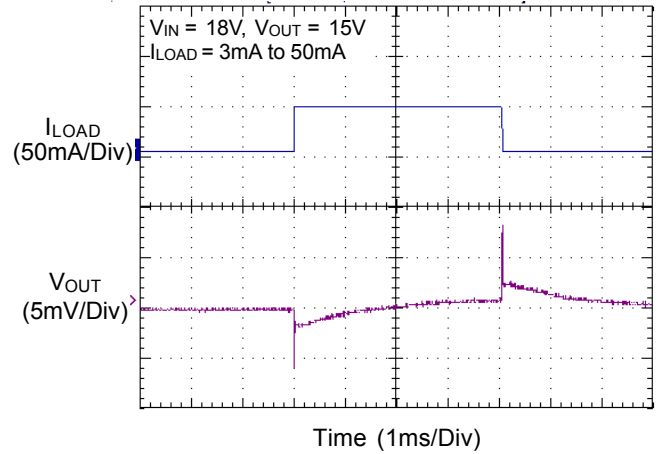

PSRR

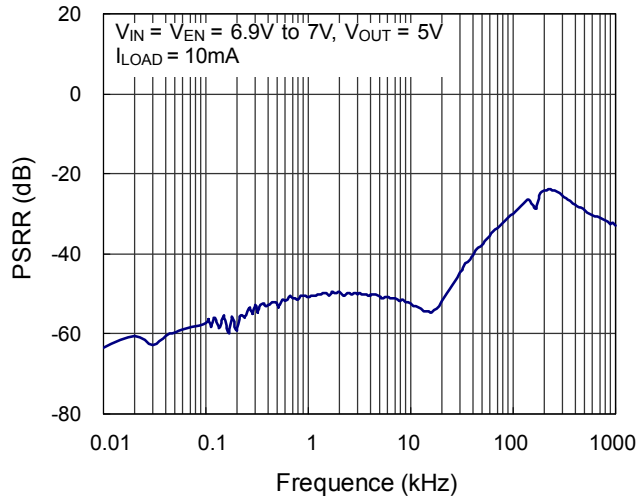

Power On/Off

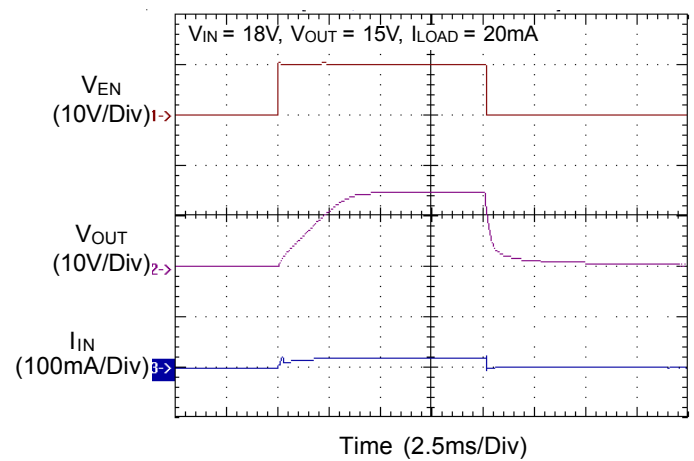

Region of Stable C_{OUT} ESR vs. Load Current

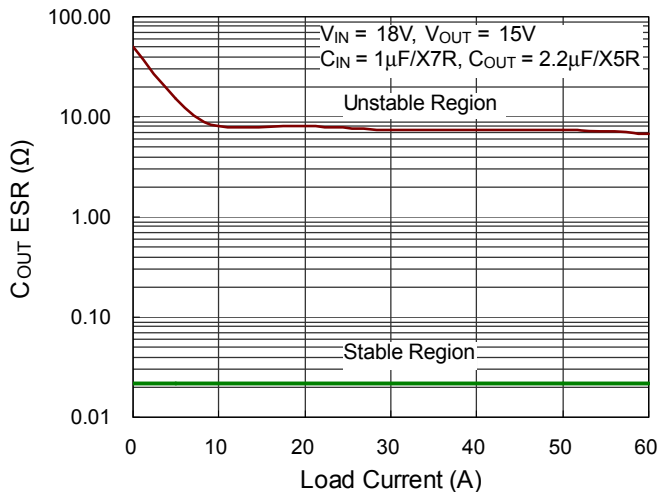

Application Information

Enable

The RT9022 goes into sleep mode when the Enable pin is in a logic low condition. During this condition, the pass transistor, error amplifier, and bandgap are turned off, reducing the supply current to 1μA. The Enable input is a CMOS logic and cannot be left floating.

Output capacitor

The RT9022 is specifically designed to use ceramic output capacitors as low as 2.2μF. Ceramic capacitors below 10μF offer significant cost and space saving, along with high frequency noise filtering. The RT9022 doesn't rely on a zero, which is generated by output capacitor ESR. So, the output capacitor ESR is not sensitive and very low ESR is allowed.

Input capacitor

A 1μF input capacitor or greater located as close as possible to the IC is recommended. Larger input capacitor value with lower ESR provides better power supply noise rejection and line transient response. Larger load current requires larger capacitor value.

PSRR

The power supply rejection ratio (PSRR) is defined as the gain from the input to output divided by the gain from the supply to the output. The PSRR is found to be

$$PSRR = 20 \times \log \left(\frac{\Delta \text{Gain Error}}{\Delta \text{Supply}} \right)$$

Note that when heavy load is measured, Δsupply will cause Δtemperature. And Δtemperature will cause Δoutput voltage. So the temperature effect must be taken into consideration.

Current Limit

The RT9022 contains an independent current limiter, which monitors and controls the pass transistor's gate voltage to limit the output current to 80mA typically. It protects the part even directly short the output to GND.

Thermal Consideration

Thermal protection limits power dissipation in the RT9022. When the operating junction temperature exceeds 135°C, the OTP circuit starts the thermal shutdown function and turns the pass element off. The pass element turns on again after the junction temperature cools by 10°C.

For continuous operation, do not exceed absolute maximum operation junction temperature 125°C. The power dissipation definition in device is :

$$P_D = (V_{IN} - V_{OUT}) \times I_{OUT} + V_{IN} \times I_Q$$

The maximum power dissipation depends on the thermal resistance of IC package, PCB layout, the rate of surroundings airflow and temperature difference between junction to ambient. The maximum power dissipation can be calculated by following formula :

$$P_{D(MAX)} = (T_{J(MAX)} - T_A) / \theta_{JA}$$

Where $T_{J(MAX)}$ is the maximum operation junction temperature 100°C, T_A is the ambient temperature and the θ_{JA} is the junction to ambient thermal resistance.

For recommended operating conditions specification of the RT9022, where $T_{J(MAX)}$ is the maximum junction temperature of the die (100°C) and T_A is the maximum ambient temperature. The junction to ambient thermal resistance (θ_{JA} is layout dependent) for T/SOT-23-6 package is 250°C/W, and SC-70-6 package is 333°C/W on standard JEDEC 51-3 thermal test board. The maximum power dissipation at $T_A = 25^\circ\text{C}$ can be calculated by following formula :

$$P_{D(MAX)} = (100^\circ\text{C} - 25^\circ\text{C}) / 250^\circ\text{C/W} = 300\text{mW for T/SOT-23-6 package}$$

$$P_{D(MAX)} = (100^\circ\text{C} - 25^\circ\text{C}) / 333^\circ\text{C/W} = 225\text{mW for SC-70-6 package}$$

The maximum power dissipation depends on operating ambient temperature for fixed $T_{J(MAX)}$ and thermal resistance θ_{JA} . For the RT9022 packages, the Figure 1 of de-rating curves allows the designer to see the effect of rising ambient temperature on the maximum power allowed.

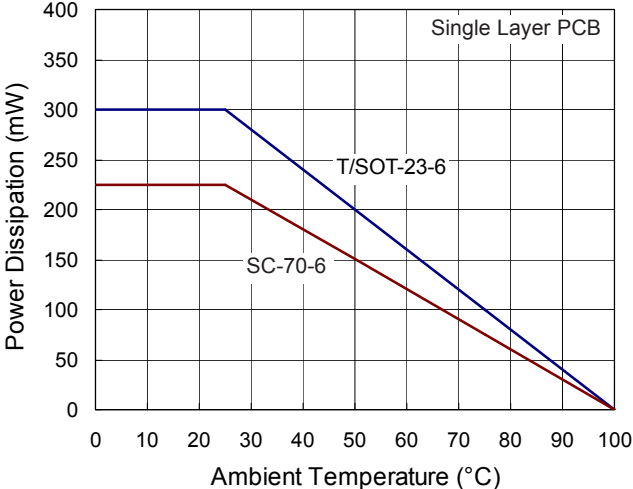
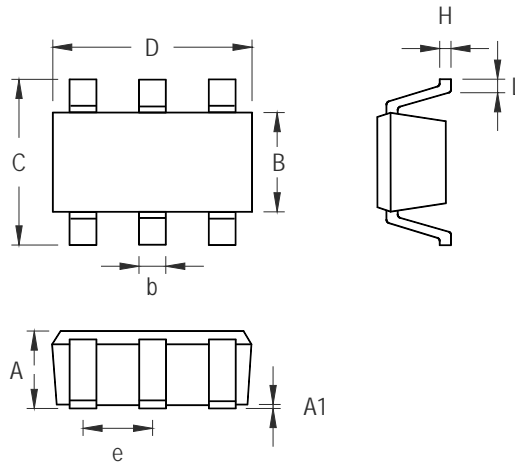

Figure 1. De-rating Curves

Outline Dimension



Symbol	Dimensions In Millimeters		Dimensions In Inches	
	Min	Max	Min	Max
A	0.889	1.295	0.031	0.051
A1	0.000	0.152	0.000	0.006
B	1.397	1.803	0.055	0.071
b	0.250	0.560	0.010	0.022
C	2.591	2.997	0.102	0.118
D	2.692	3.099	0.106	0.122
e	0.838	1.041	0.033	0.041
H	0.080	0.254	0.003	0.010
L	0.300	0.610	0.012	0.024

SOT-23-6 Surface Mount Package

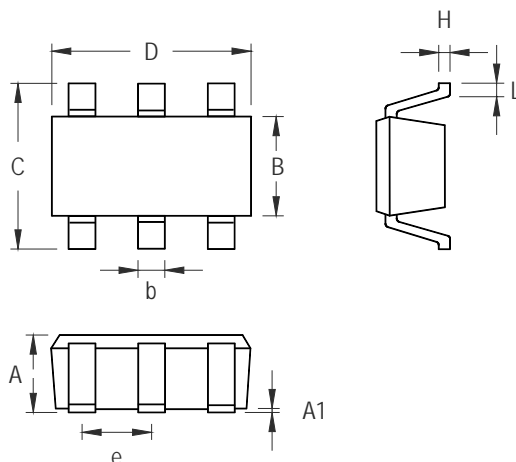

Symbol	Dimensions In Millimeters		Dimensions In Inches	
	Min	Max	Min	Max
A	0.700	1.000	0.028	0.039
A1	0.000	0.100	0.000	0.004
B	1.397	1.803	0.055	0.071
b	0.300	0.559	0.012	0.022
C	2.591	3.000	0.102	0.118
D	2.692	3.099	0.106	0.122
e	0.838	1.041	0.033	0.041
H	0.080	0.254	0.003	0.010
L	0.300	0.610	0.012	0.024

TSOT-23-6 Surface Mount Package

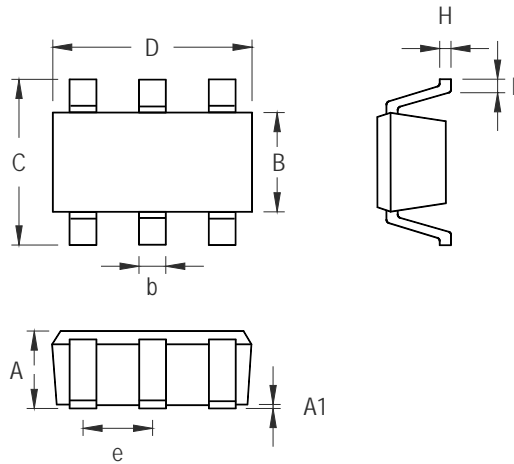

Symbol	Dimensions In Millimeters		Dimensions In Inches	
	Min	Max	Min	Max
A	0.800	1.100	0.031	0.044
A1	0.000	0.100	0.000	0.004
B	1.150	1.350	0.045	0.054
b	0.150	0.400	0.006	0.016
C	1.800	2.450	0.071	0.096
D	1.800	2.250	0.071	0.089
e	0.650		0.026	
H	0.080	0.260	0.003	0.010
L	0.210	0.460	0.008	0.018

SC-70-6 Surface Mount Package

Richtek Technology Corporation

Headquarter
 5F, No. 20, Taiyuen Street, Chupei City
 Hsinchu, Taiwan, R.O.C.
 Tel: (8863)5526789 Fax: (8863)5526611

Richtek Technology Corporation

Taipei Office (Marketing)
 8F, No. 137, Lane 235, Paochiao Road, Hsintien City
 Taipei County, Taiwan, R.O.C.
 Tel: (8862)89191466 Fax: (8862)89191465
 Email: marketing@richtek.com