

ZXT951K

60V PNP LOW SATURATION MEDIUM POWER TRANSISTOR IN D-PAK

SUMMARY

$BV_{CEO} = -60V$; $R_{SAT} = 53m\Omega$ typical; $I_C = -6A$

DESCRIPTION

Packaged in the D-PAK outline this high current high performance 60V PNP transistor offers low on state losses making it ideal for use in DC-DC circuits and various driving and power management functions.

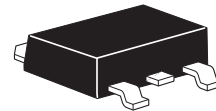

DPAK

FEATURES

- 6 amps continuous current
- Up to 15 amps peak current
- Low equivalent on resistance
- Low saturation voltages

APPLICATIONS

- DC - DC converters
- DC - DC modules
- Power switches
- Motor control
- Automotive circuits
- Inverter circuits

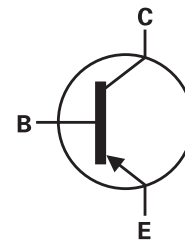

ORDERING INFORMATION

DEVICE	REEL SIZE	TAPE WIDTH	QUANTITY PER REEL
ZXT951KTC	13"	16mm	2500 units

PINOUT

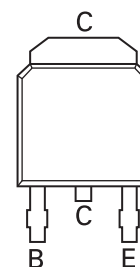

TOP VIEW

DEVICE MARKING

- ZXT951

ZXT951K

ABSOLUTE MAXIMUM RATINGS

PARAMETER	SYMBOL	LIMIT	UNIT
Collector-base voltage	BV_{CBO}	-100	V
Collector-base voltage	BV_{CER}	-100	V
Collector-emitter voltage	BV_{CEO}	-60	V
Emitter-base voltage	BV_{EBO}	-7	V
Peak pulse current	I_{CM}	-15	A
Continuous collector current ^(b)	I_C	-6	A
Base current	I_B	-0.5	A
Power dissipation at $T_A = 25^\circ\text{C}$ ^(a)	P_D	2.1	W
Linear derating factor		16.8	mW/ $^\circ\text{C}$
Power dissipation at $T_A = 25^\circ\text{C}$ ^(b)	P_D	3.2	W
Linear derating factor		25.6	mW/ $^\circ\text{C}$
Power dissipation at $T_A = 25^\circ\text{C}$ ^(c)	P_D	4.2	W
Linear derating factor		33.6	mW/ $^\circ\text{C}$
Operating and storage temperature range	T_j, T_{stg}	-55 to +150	$^\circ\text{C}$

THERMAL RESISTANCE

PARAMETER	SYMBOL	VALUE	UNIT
Junction to ambient ^(a)	$R_{\theta JA}$	59	$^\circ\text{C}/\text{W}$
Junction to ambient ^(b)	$R_{\theta JA}$	39	$^\circ\text{C}/\text{W}$
Junction to ambient ^(c)	$R_{\theta JA}$	30	$^\circ\text{C}/\text{W}$

NOTES

- (a) For a device surface mounted on 25mm x 25mm x 1.6mm FR4 PCB with high coverage of single sided 1oz copper in still air conditions.
(b) For a device surface mounted on 50mm x 50mm x 1.6mm FR4 PCB with high coverage of single sided 1oz copper in still air conditions.
(c) For a device surface mounted on 25mm x 25mm x 1.6mm FR4 PCB with high coverage of single sided 2oz copper in still air conditions.

ZXT951K

TYPICAL CHARACTERISTICS

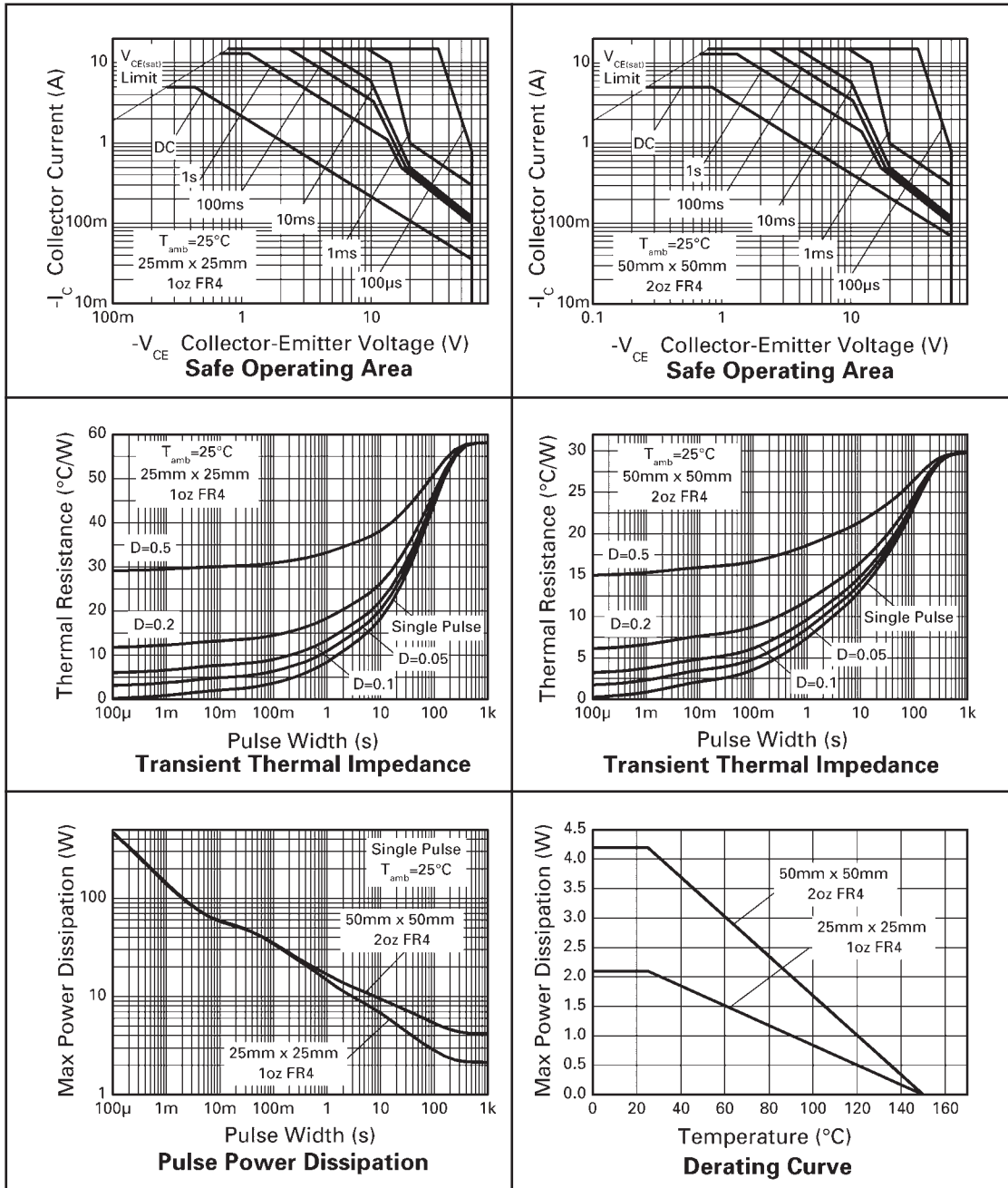

ZXT951K

ELECTRICAL CHARACTERISTICS (at $T_{amb} = 25^{\circ}\text{C}$ unless otherwise stated)

PARAMETER	SYMBOL	MIN.	TYP.	MAX.	UNIT	CONDITIONS
Collector-base breakdown voltage	BV_{CBO}	-100	-125		V	$I_C = -100\mu\text{A}$
Collector-emitter breakdown voltage	BV_{CER}	-100	-125		V	$I_C = -100\mu\text{A}$, $R_{BE} \leq 1\text{k}\Omega$
Collector-emitter breakdown voltage	BV_{CEO}	-60	-80		V	$I_C = -10\text{mA}^*$
Emitter-base breakdown voltage	BV_{EBO}	-7	-8.1		V	$I_E = -100\mu\text{A}$
Collector cut-off current	I_{CBO}		<1	-20	nA	$V_{CB} = -80\text{V}$
Collector cut-off current	I_{CER}		<1	-20	nA	$V_{CB} = -80\text{V}$, $R_{BE} \leq 1\text{k}\Omega$
Emitter cut-off current	I_{EBO}		<1	-10	nA	$V_{EB} = -6\text{V}$
Collector-emitter saturation voltage	$V_{CE(SAT)}$		-13	-25	mV	$I_C = -0.1\text{A}$, $I_B = -10\text{mA}^*$
			-60	-90	mV	$I_C = -1\text{A}$, $I_B = -100\text{mA}^*$
			-115	-165	mV	$I_C = -2\text{A}$, $I_B = -200\text{mA}^*$
			-315	-400	mV	$I_C = -6\text{A}$, $I_B = -600\text{mA}^*$
Base-emitter saturation voltage	$V_{BE(SAT)}$		-1.05	-1.2	mV	$I_C = -6\text{A}$, $I_B = -600\text{mA}^*$
Base-emitter turn-on voltage	$V_{BE(ON)}$		-0.92	-1.05	mV	$I_C = -6\text{A}$, $V_{CE} = -1\text{V}^*$
Static forward current transfer ratio	H_{FE}	100	230			$I_C = -10\text{mA}$, $V_{CE} = -1\text{V}^*$
		100	200	300		$I_C = -2\text{A}$, $V_{CE} = -1\text{V}^*$
		50	110			$I_C = -6\text{A}$, $V_{CE} = -1\text{V}^*$
		15	40			$I_C = -10\text{A}$, $V_{CE} = -1\text{V}^*$
Transition frequency	f_T		120		MHz	$I_C = -100\text{mA}$, $V_{CE} = -10\text{V}$ $f = 50\text{MHz}$
Output capacitance	C_{OBO}		74		pF	$V_{CB} = -10\text{V}$, $f = 1\text{MHz}^*$
Switching times	t_{ON}		82		nS	$I_C = -2\text{A}$, $V_{CC} = -10\text{V}$,
	t_{OFF}		350		nS	$I_{B1} = I_{B2} = -200\text{mA}$

* Measured under pulsed conditions. Pulse width $\leq 300\mu\text{s}$; duty cycle $\leq 2\%$.

TYPICAL CHARACTERISTICS

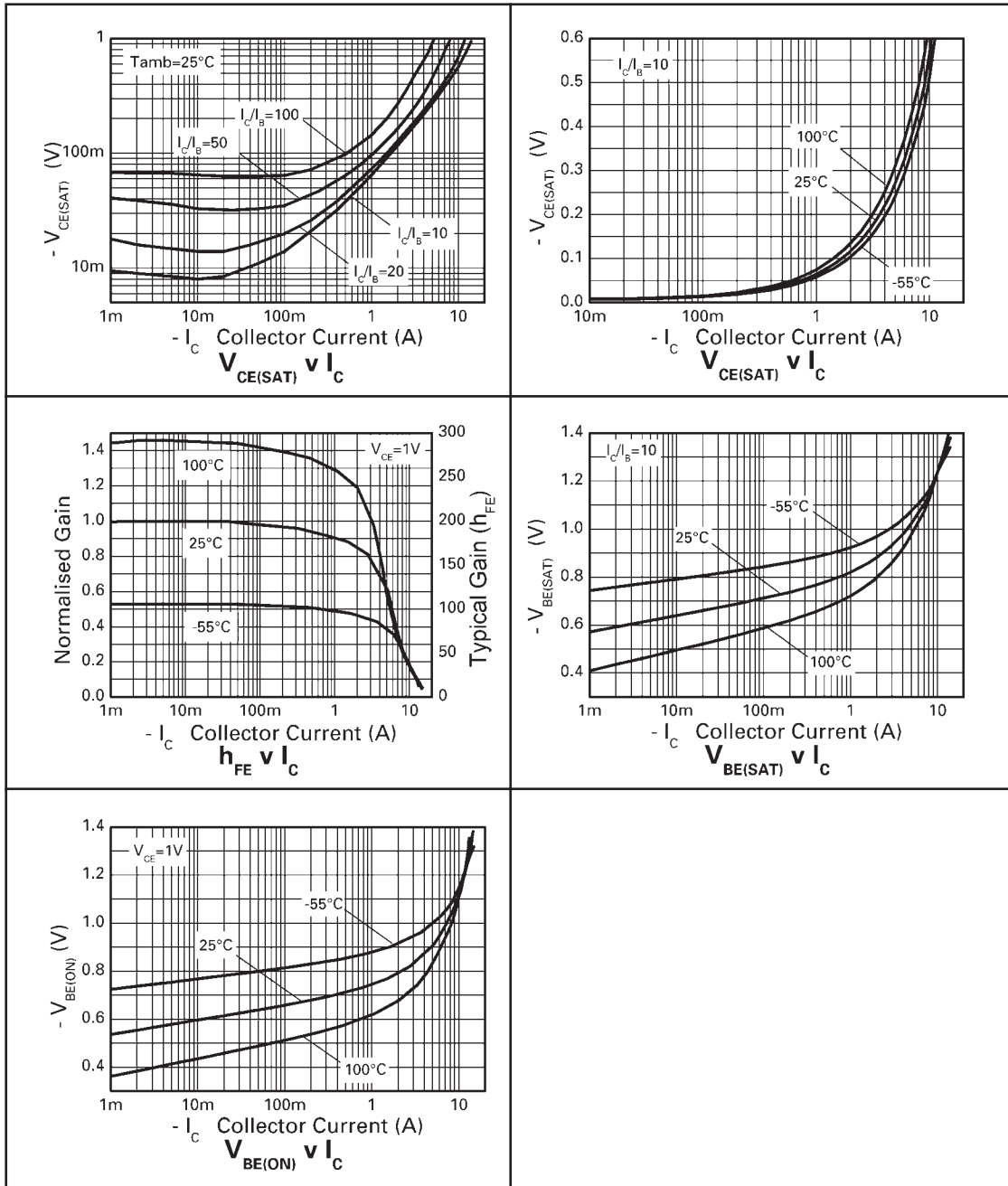

ZXT951K

PACKAGE OUTLINE

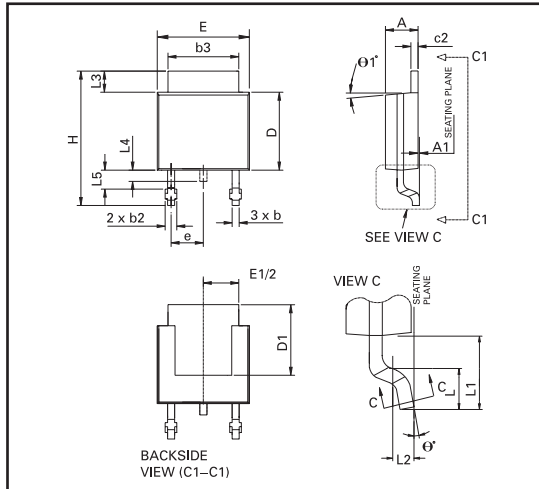

Controlling dimensions are in millimeters. Approximate conversions are given in inches

PACKAGE DIMENSIONS

DIM	Millimeters		Inches		DIM	Millimeters		Inches	
	Min	Max	Min	Max		Min	Max	Min	Max
A	2.18	2.38	0.086	0.094	e	2.30 BSC		0.090 BSC	
A1	—	0.127	—	0.005	H	9.40	10.41	0.370	0.410
b	0.635	0.89	0.025	0.035	L	1.40	1.78	0.055	0.070
b2	0.762	1.114	0.030	0.045	L1	2.74 REF		0.108 REF	
b3	5.20	5.46	0.205	0.215	L2	0.051 BSC		0.020 BSC	
c	0.457	0.609	0.018	0.024	L3	0.89	1.27	0.035	0.050
c2	0.457	0.584	0.018	0.023	L4	0.635	1.01	0.025	0.040
D	5.97	6.22	0.235	0.245	L5	1.14	1.52	0.045	0.060
D1	5.20	—	0.205	—	θ1°	0°	10°	0°	10°
E	6.35	6.73	0.250	0.265	θ°	0°	15°	0°	15°
E1	4.32	—	0.170	—	—	—	—	—	—

© Zetex plc 2003

Europe	Americas	Asia Pacific
Zetex plc Fields New Road Chadderton Oldham, OL9 8NP United Kingdom Telephone (44) 161 622 4444 Fax: (44) 161 622 4446 hq@zetex.com	Zetex GmbH Streitfeldstraße 19 D-81673 München Germany Telefon: (49) 89 45 49 49 0 Fax: (49) 89 45 49 49 49 europe.sales@zetex.com	Zetex (Asia) Ltd 3701-04 Metroplaza Tower 1 Hing Fong Road Kwai Fong Hong Kong Telephone: (852) 26100 611 Fax: (852) 24250 494 asia.sales@zetex.com

These offices are supported by agents and distributors in major countries world-wide.

This publication is issued to provide outline information only which (unless agreed by the Company in writing) may not be used, applied or reproduced for any purpose or form part of any order or contract or be regarded as a representation relating to the products or services concerned. The Company reserves the right to alter without notice the specification, design, price or conditions of supply of any product or service.

For the latest product information, log on to www.zetex.com



ISSUE 2 - DECEMBER 2003