

# TIPP31, TIPP31A, TIPP31B, TIPP31C NPN SILICON POWER TRANSISTORS

Copyright © 1997, Power Innovations Limited, UK

MAY 1989 - REVISED MARCH 1997

- 20 W Pulsed Power Dissipation
- 100 V Capability
- 2 A Continuous Collector Current
- 4 A Peak Collector Current
- Customer-Specified Selections Available

LP PACKAGE  
(TOP VIEW)

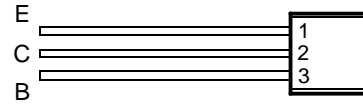

MDTRAB

## absolute maximum ratings at 25°C case temperature (unless otherwise noted)

RATING		SYMBOL	VALUE	UNIT
Collector-base voltage ( $I_E = 0$ )	TIPP31	$V_{CBO}$	40	V
	TIPP31A		60	
	TIPP31B		80	
	TIPP31C		100	
Collector-emitter voltage ( $I_B = 0$ )	TIPP31	$V_{CEO}$	40	V
	TIPP31A		60	
	TIPP31B		80	
	TIPP31C		100	
Emitter-base voltage		$V_{EBO}$	5	V
Continuous collector current		$I_C$	2	A
Peak collector current (see Note 1)		$I_{CM}$	4	A
Continuous base current		$I_B$	1	A
Continuous device dissipation at (or below) 25°C case temperature (see Note 2)		$P_{tot}$	0.8	W
Pulsed power dissipation (see Note 3)		$P_T$	20	W
Operating junction temperature range		$T_j$	-55 to +150	°C
Storage temperature range		$T_{stg}$	-55 to +150	°C
Lead temperature 3.2 mm from case for 10 seconds		$T_L$	260	°C

- NOTES: 1. This value applies for  $t_p \leq 0.3$  ms, duty cycle  $\leq 10\%$ .  
 2. Derate linearly to 150°C case temperature at the rate of 6.4 mW/°C.  
 3.  $V_{CE} = 20$  V,  $I_C = 1$  A,  $t_p = 10$  ms, duty cycle  $\leq 2\%$ .

## PRODUCT INFORMATION

Information is current as of publication date. Products conform to specifications in accordance with the terms of Power Innovations standard warranty. Production processing does not necessarily include testing of all parameters.



# TIPP31, TIPP31A, TIPP31B, TIPP31C

## NPN SILICON POWER TRANSISTORS

MAY 1989 - REVISED MARCH 1997

### electrical characteristics at 25°C case temperature

PARAMETER	TEST CONDITIONS			MIN	TYP	MAX	UNIT
$V_{(BR)CEO}$ Collector-emitter breakdown voltage	$I_C = 5 \text{ mA}$ (see Note 4)	$I_B = 0$	TIPP31 TIPP31A TIPP31B TIPP31C	40 60 80 100			V
$I_{CES}$ Collector-emitter cut-off current	$V_{CE} = 40 \text{ V}$ $V_{CE} = 60 \text{ V}$ $V_{CE} = 80 \text{ V}$ $V_{CE} = 100 \text{ V}$	$V_{BE} = 0$ $V_{BE} = 0$ $V_{BE} = 0$ $V_{BE} = 0$	TIPP31 TIPP31A TIPP31B TIPP31C			0.2 0.2 0.2 0.2	mA
$I_{CEO}$ Collector cut-off current	$V_{CE} = 30 \text{ V}$ $V_{CE} = 60 \text{ V}$	$I_B = 0$ $I_B = 0$	TIPP31/31A TIPP31B/31C			0.3 0.3	mA
$I_{EBO}$ Emitter cut-off current	$V_{EB} = 5 \text{ V}$	$I_C = 0$				1	mA
$h_{FE}$ Forward current transfer ratio	$V_{CE} = 4 \text{ V}$ $V_{CE} = 4 \text{ V}$	$I_C = 1 \text{ A}$ $I_C = 2 \text{ A}$	(see Notes 4 and 5)	20 10			
$V_{CE(sat)}$ Collector-emitter saturation voltage	$I_B = 375 \text{ mA}$	$I_C = 2 \text{ A}$	(see Notes 4 and 5)			1	V
$V_{BE}$ Base-emitter voltage	$V_{CE} = 4 \text{ V}$	$I_C = 2 \text{ A}$	(see Notes 4 and 5)			1.5	V
$h_{fe}$ Small signal forward current transfer ratio	$V_{CE} = 10 \text{ V}$	$I_C = 0.5 \text{ A}$	$f = 1 \text{ kHz}$	20			
$ h_{fe} $ Small signal forward current transfer ratio	$V_{CE} = 10 \text{ V}$	$I_C = 0.5 \text{ A}$	$f = 1 \text{ MHz}$	3			

NOTES: 4. These parameters must be measured using pulse techniques,  $t_p = 300 \mu\text{s}$ , duty cycle  $\leq 2\%$ .

5. These parameters must be measured using voltage-sensing contacts, separate from the current carrying contacts.

MECHANICAL DATA

LP003 (TO-92)

3-pin cylindrical plastic package

This single-in-line package consists of a circuit mounted on a lead frame and encapsulated within a plastic compound. The compound will withstand soldering temperature with no deformation, and circuit performance characteristics will remain stable when operated in high humidity conditions. Leads require no additional cleaning or processing when used in soldered assembly.

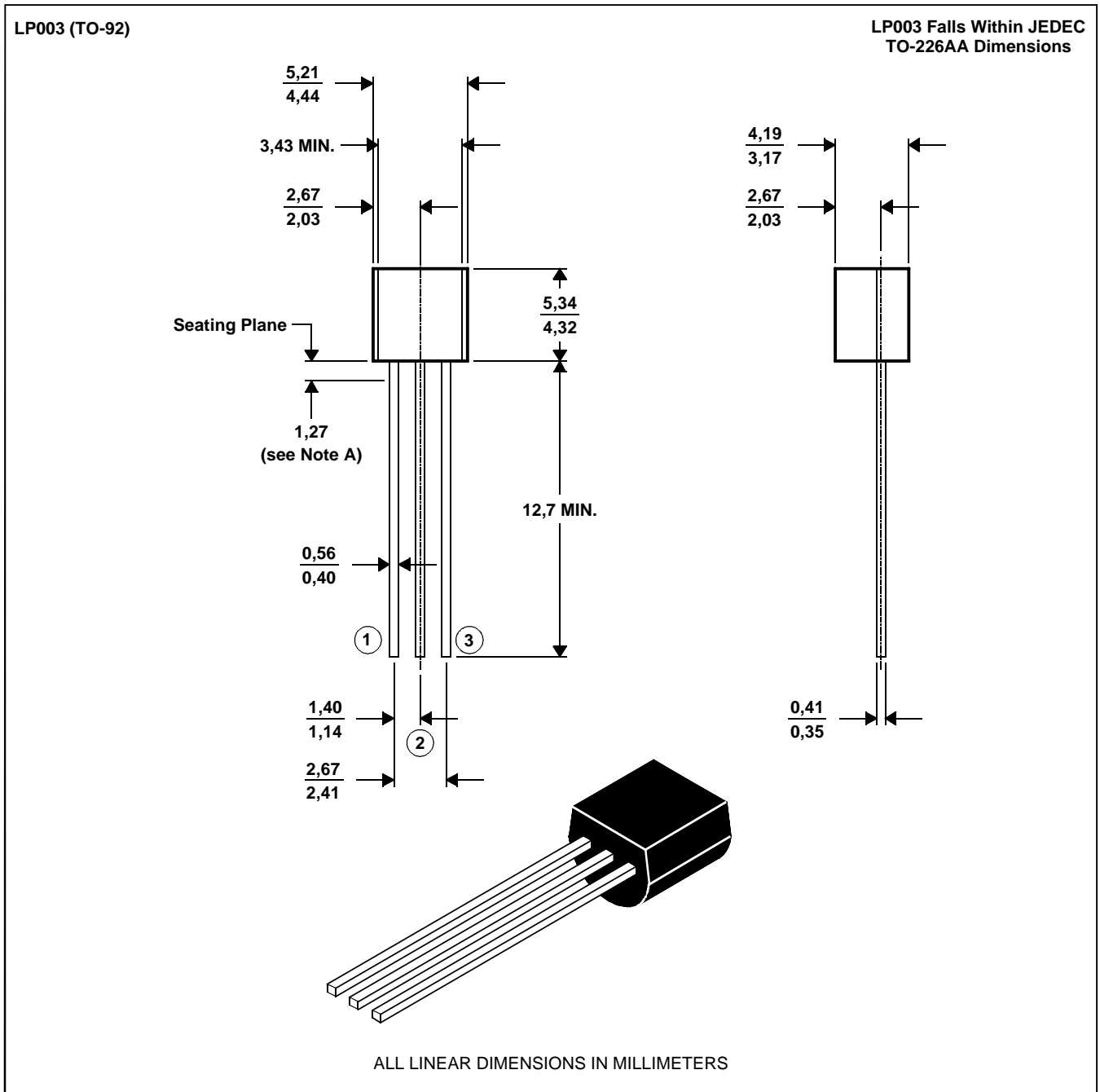

NOTE A: Lead dimensions are not controlled in this area.

MDXXAX

# TIPP31, TIPP31A, TIPP31B, TIPP31C NPN SILICON POWER TRANSISTORS

MAY 1989 - REVISED MARCH 1997

## MECHANICAL DATA

### LP003 (TO-92)

#### 3-pin cylindrical plastic package

This single-in-line package consists of a circuit mounted on a lead frame and encapsulated within a plastic compound. The compound will withstand soldering temperature with no deformation, and circuit performance characteristics will remain stable when operated in high humidity conditions. Leads require no additional cleaning or processing when used in soldered assembly.

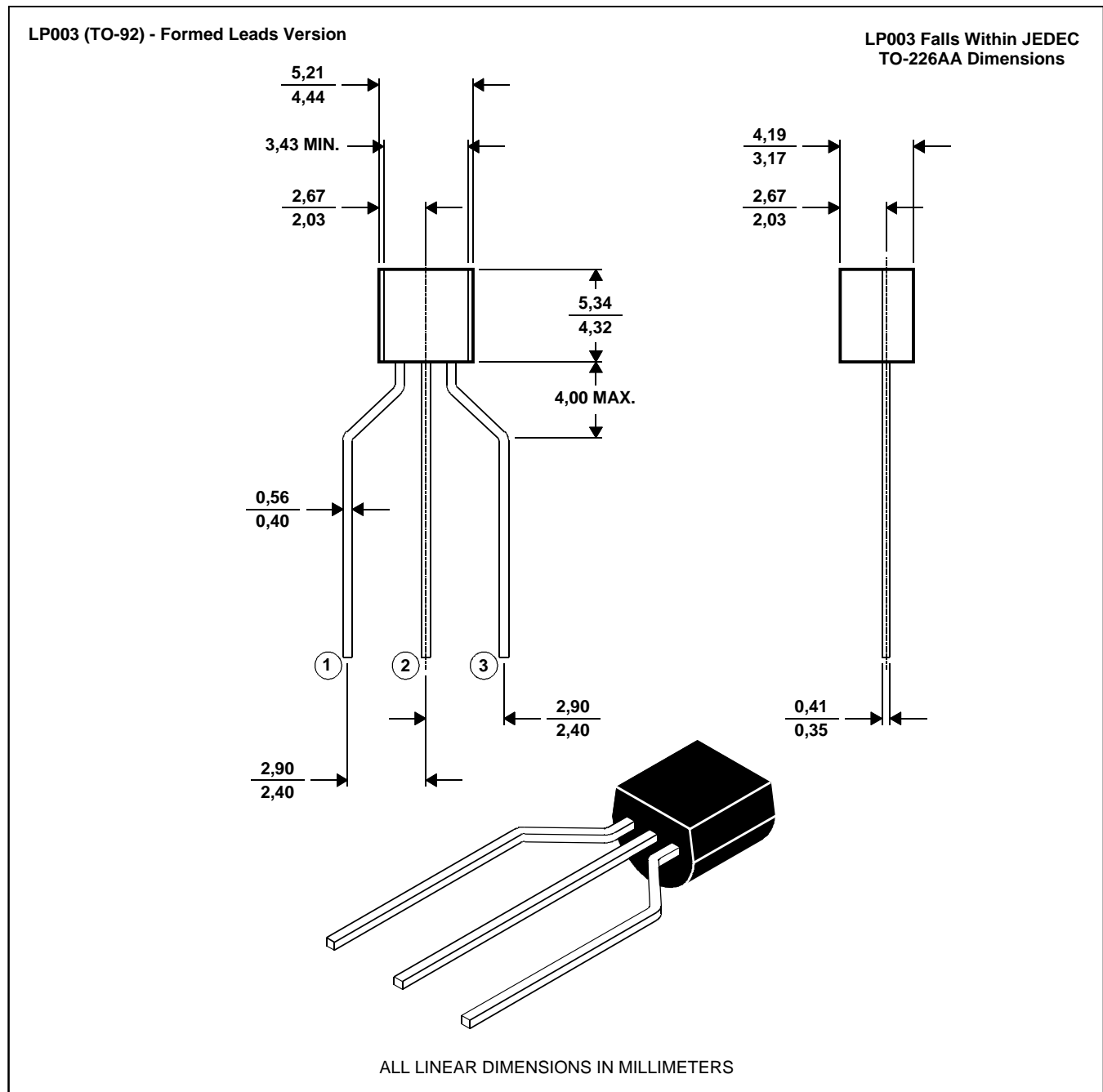

MDXXAR

MECHANICAL DATA

LPR  
tape dimensions

LP Package (TO-92) Tape (Formed Lead Version)

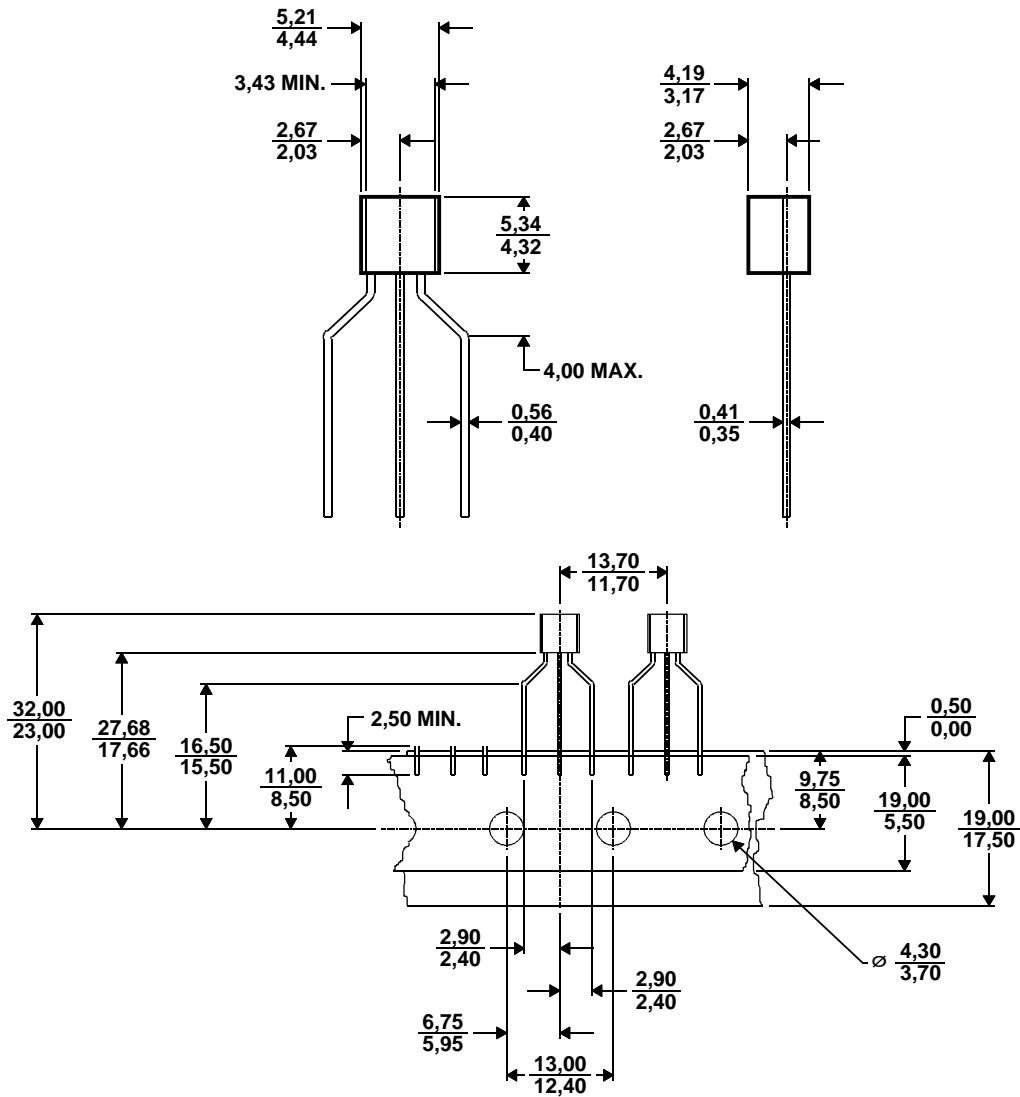

ALL LINEAR DIMENSIONS IN MILLIMETERS

MDXXAS

# TIPP31, TIPP31A, TIPP31B, TIPP31C NPN SILICON POWER TRANSISTORS

MAY 1989 - REVISED MARCH 1997

---

## IMPORTANT NOTICE

Power Innovations Limited (PI) reserves the right to make changes to its products or to discontinue any semiconductor product or service without notice, and advises its customers to verify, before placing orders, that the information being relied on is current.

PI warrants performance of its semiconductor products to the specifications applicable at the time of sale in accordance with PI's standard warranty. Testing and other quality control techniques are utilized to the extent PI deems necessary to support this warranty. Specific testing of all parameters of each device is not necessarily performed, except as mandated by government requirements.

PI accepts no liability for applications assistance, customer product design, software performance, or infringement of patents or services described herein. Nor is any license, either express or implied, granted under any patent right, copyright, design right, or other intellectual property right of PI covering or relating to any combination, machine, or process in which such semiconductor products or services might be or are used.

PI SEMICONDUCTOR PRODUCTS ARE NOT DESIGNED, INTENDED, AUTHORIZED, OR WARRANTED TO BE SUITABLE FOR USE IN LIFE-SUPPORT APPLICATIONS, DEVICES OR SYSTEMS.

Copyright © 1997, Power Innovations Limited