

VI TELEFILTER

Filter specification

TFS 211-1

Measurement condition

Ambient temperature: 23 °C
 Input power level: 10 dBm
 Terminating impedance:
 Input: 280 Ω || -3,7 pF
 Output: 280 Ω || -3,7 pF
 External coil: 127 nH

The filter supports bursted GMSK and EDGE modulation.

Characteristics

Remark:

Reference level for the relative attenuation a_{rel} of the TFS 211-1 is the filter attenuation at 211 MHz. The filter attenuation at 211 MHz is called insertion loss a_e . The centre frequency f_c is the arithmetic mean value of the upper and lower frequencies at the 3 dB filter attenuation level relative to the insertion loss a_e . The given values for the relative attenuation a_{rel} and for the group delay ripple have to be reached at the frequencies given below also if the centre frequency f_c is shifted due to the temperature coefficient of frequency TC_f in the operating temperature range and due to a production tolerance for the centre frequency f_c .

D a t a		typ. value		tolerance / limit	
Insertion loss (Reference level)	$a_e = a_{min}$	4,5	dB	max	6,5 dB
Centre frequency	f_c	211,0	MHz	211,0 MHz ± 25 kHz	
Nominal frequency	f_N			211,0 MHz	
3dB Bandwidth		270	kHz	min	215 kHz
Relative attenuation	a_{rel}				
$f_N ± 50$ kHz	... $f_N ± 50$ kHz	-		max	1,5 dB
$f_N ± 80$ kHz	... $f_N ± 80$ kHz	-		max	2 dB
$f_N ± 100$ kHz	... $f_N ± 100$ kHz	-		max	3 dB
$f_N ± 200$ kHz	... $f_N ± 200$ kHz	-		min	3 dB
$f_N ± 400$ kHz	... $f_N ± 400$ kHz	-		min	25 dB
$f_N ± 600$ kHz	... $f_N ± 600$ kHz	-		min	35 dB
$f_N ± 800$ kHz	... $f_N ± 800$ kHz	-		min	40 dB
Group delay at f_N	GD	3,4	µs	max	5 µs
Group delay ripple	$f_N ± 50$ kHz	-		max	1,0 µs
Out of band intermodulation					
Input signals at 211,8 and 212,6 MHz at +10 dBm		-71	dBm	-	
Input signals at 210,2 and 209,4 MHz at +10 dBm		-71	dBm	-	
Input power level		-		max	15 dBm
for less than 1 hour over life time		-		max	25 dBm
$f_N ± 800$ kHz	... $f_N ± 3$ MHz	-		max	22 dBm
$f_N ± 3$ MHz	... $f_N ± 100$ MHz	-		max	25 dBm
Return loss (S11/S22)	$f_N ± 100$ kHz			min	10 dB
Operating temperature range				- 5 °C ... + 80 °C	
Storage temperature range				- 40 °C ... + 85 °C	
Temperature coefficient of frequency		ca. - 0,036	ppm/K		
Frequency inversion temperature		+ 20	°C		

Generated: _____

Checked / Approved: _____

Tele Filter GmbH
 Potsdamer Straße 18
 D 14 513 TELTOW / Germany
 Tel: (+49) 3328 4784-0 / Fax: (+49) 3328 4784-30
 E-Mail: tft@telefilter.com

VI TELEFILTER reserves the right to make changes to the product(s) and/or information contained herein without notice. No liability is assumed as a result of their use or application. No rights under any patent accompany the sale of any such product(s) or information.

Construction, pin connection and 50 Ω - matching network

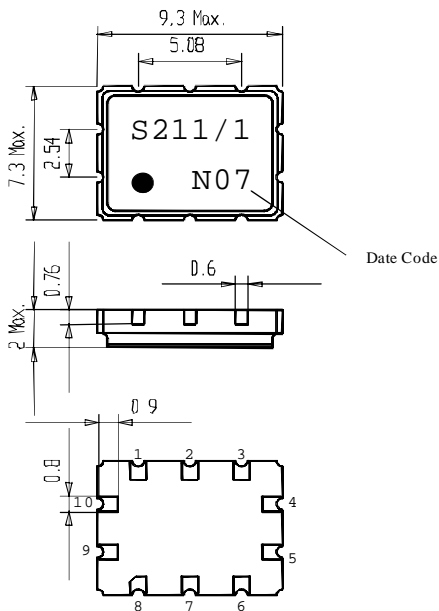

- | | |
|-----------------|-----------|
| 1 Output | 6 Input |
| 2 Ground | 7 Ground |
| 3 External Coil | 8 Ground |
| 4 Ground | 9 Ground |
| 5 Ground | 10 Ground |

Date Code: Year + week
 L 1999
 M 2000
 N 2001
 ...

50 Ohm matching networks

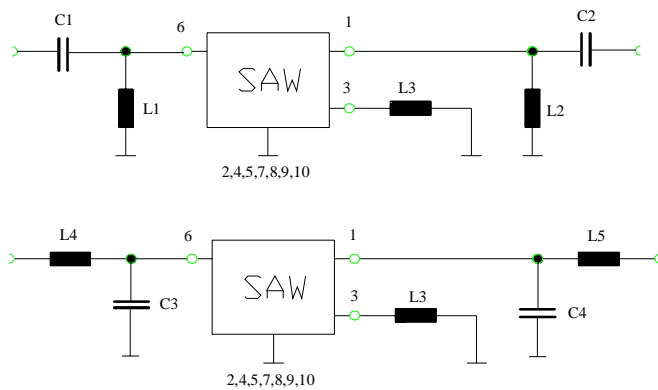

Tele Filter GmbH
 Potsdamer Straße 18
 D 14 513 TELTOW / Germany
 Tel: (+49) 3328 4784-0 / Fax: (+49) 3328 4784-30
 E-Mail: tft@telefilter.com

VI TELEFILTER reserves the right to make changes to the product(s) and/or information contained herein without notice. No liability is assumed as a result of their use or application. No rights under any patent accompany the sale of any such product(s) or information.

VI TELEFILTER

Filter specification

TFS 211-1

3/5

Stability Characteristics

After the following tests the filter shall meet the whole specification:

1. Shock: 500g, 18 ms, half sine wave, 3 shocks each plane;
DIN IEC 68 T2 - 27
2. Vibration: 10 Hz to 500 Hz, 0,35 mm or 5g respectively, 1 octave per min, 10 cycles per plan, 3 plans;
DIN IEC 68 T2 - 6
3. Damp heat: 25 °C to 55°C / 95% r.H. / 10 cycles
(cycle) DIN IEC 68 - 2 – 30 Db
4. Resistance to solder heat (reflow): max. 2 times reflow process;
for temperature conditions refer to the attached "Air reflow temperature conditions" on page 4;
5. ESD MIL-STD-883E using coupling network of ISO 10605 and EN 6100-4-2
HBM:250V; MM:200V;

Packing

Tape & Reel: IEC 286 – 3, with exception of value for N and minimum bending radius;
tape type II, embossed carrier tape with top cover tape on the upper side;

max. pieces of filters peer reel:	3000
reel of empty components at start:	min. 300 mm
reel of empty components at start including leader:	min. 500 mm
trailer:	min. 300 mm

Tape (all dimensions in mm)

- W : 16,00 ± 0,3
- Po : 4,00 ± 0,1
- Do : 1,50 +0,1/-0
- E : 1,75 ± 0,10
- F : 7,50 ± 0,10
- G(min) : 0,60
- P2 : 2,00 ± 0,1
- P1 : 12,00 ± 0,1
- D1(min) : 1,50 +0,1/-0
- Ao : 7,60 ± 0,10
- Bo : 9,60 ± 0,10
- Ct : 13,5

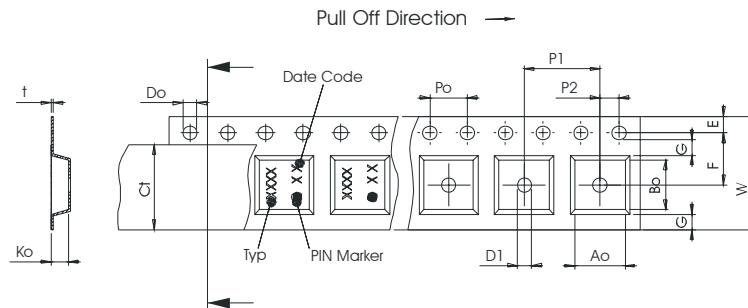

Reel (all dimensions in mm)

- A : 330
- W1 : 16,4
- W2(max) : 22,4
- N(min) : 50
- C : 13,0

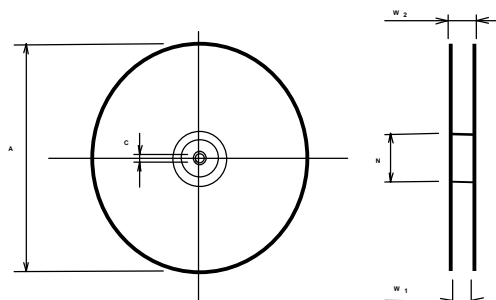

The minimum bending radius is 45 mm.

Tele Filter GmbH
Potsdamer Straße 18
D 14 513 TELTOW / Germany
Tel: (+49) 3328 4784-0 / Fax: (+49) 3328 4784-30
E-Mail: tft@telefilter.com

VI TELEFILTER reserves the right to make changes to the product(s) and/or information contained herein without notice. No liability is assumed as a result of their use or application. No rights under any patent accompany the sale of any such product(s) or information.

Air reflow temperature conditions

1st and 2nd air reflow profile

Name:	pre-heating periods	main-heating periods	peak temperature
Temperature:	150 °C - 170 °C	over 200 °C	255 °C ± 5 °C
Time:	60 sec. - 90 sec.	20 sec. - 25 sec.	

Chip-mount air reflow profile

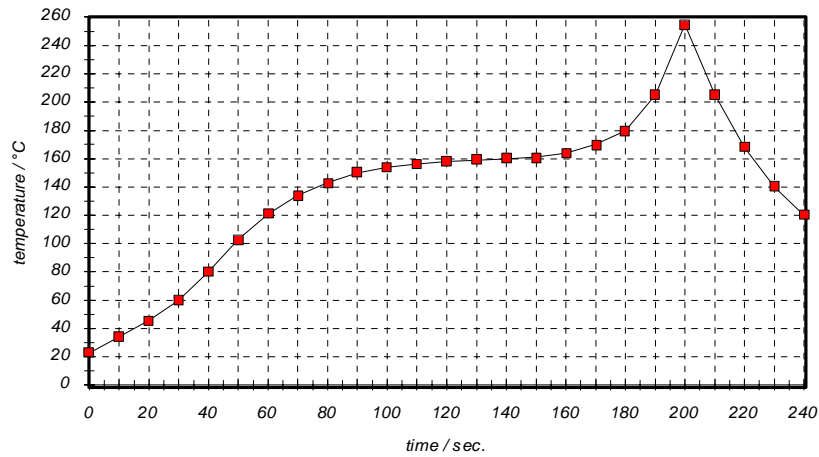

Table for temperature vs. time during the air reflow process

Tolerance of temperatures: ± 5 °C

time / sec.	temperature / °C	time / sec.	temperature / °C
0	23	140	160
10	34	150	161
20	46	160	164
30	60	170	170
40	80	180	180
50	103	190	205
60	121	195	230
70	134	200	255
80	143	205	230
90	150	210	205
100	154	215	180
110	156	220	165
120	158	230	140
130	159	240	120

VI TELEFILTER**Filter specification****TFS 211-1****5/5****History**

Version	Reason of Changes	Name	Date
1.3	Change date code to weekly date code. Change filter labelling. Correct tape and reel information.	Dr. Wall	13.07.2000
1.4	Change stop band attenuation and operating temperature range according to customer's request.	Dr. Wall	20.12.2000
1.5	Change stop band attenuation in frequency range $f_N \pm 600$ kHz ... $f_N \pm 800$ kHz according to customer requests. Add maximum input power. Add support of bursted GMSK and EDGE modulation.	Dr. Wall	22.01.2001
1.6	Change power handling, intermodulation and operating temperature range according to customer's request.	Dr. Wall	15.02.2001
1.7	Change input power level for final test from 0 dBm to 10 dBm	Dr. Wall	27.02.2001
1.8.	ESD limits added	Strehl	03.09.2004

Tele Filter GmbH
Potsdamer Straße 18
D 14 513 TELTOW / Germany
Tel: (+49) 3328 4784-0 / Fax: (+49) 3328 4784-30
E-Mail: tft@telefilter.com

VI TELEFILTER reserves the right to make changes to the product(s) and/or information contained herein without notice. No liability is assumed as a result of their use or application. No rights under any patent accompany the sale of any such product(s) or information.