

# MODEL SWTW

## Tactile Switches 6 x 6 mm and 8 x 8mm Sealed, Washable RoHS Compliant

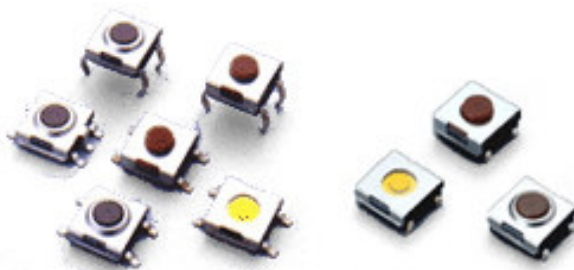

### STYLES AVAILABLE

Top Actuation SMD – G Pin, 6 x 6 mm	SWTW-G
Top Actuation SMD – G pin with Ground, 6 x 6 mm	SWTW-X
Top Actuation SMD – J pin, 6 x 6 mm	SWTW-J
Side Actuation SMD – J pin, 6 x 6 mm	SWTW-S
Top Actuation Through Hole, 6 x 6 mm	SWTW-H
Side Actuation Through Hole, 8 x 8 mm	SWTW-R
Top Actuation Through Hole, 8 x 8 mm	SWTW-K

### ELECTRICAL

Contact Resistance	100 mlli $\Omega$ max
Insulation Resistance	100 M $\Omega$ min. at 500VDC
Dielectric Strength	AC 250VAC / Minute
Rating	DC 12V / 50 mA ( DC 50V/50mA for SWTW-R only )

### ENVIRONMENTAL (MIL-R-39023)

Life Mechanical (range)	100K Cycles : Stem heights 1 & 2, 500K Cycles : Others (200K cycles : SWTW-S only) (1 Millions cycles : SWTW-R and SWTW-K only)
Operating Force Range (refer to ordering information)	130 gf – 360 gf
Operating Temperature Range	-25°C – 70°C, ( -40°C to +90°C for SWTW-R and SWTW-K only )
Storage Temperature Range	-30°C – 80°C, ( -40°C to +90°C for SWTW-R and SWTW-K only )
Stop Strength	Vertical Static Load of 3Kg continuously for 15 sec
Vibration	Mil-STD-202F, Method 201A
Shock	Mil-STD-202F, Method 213B Condition A
Soldering	Profile available upon request

# MODEL SWTW

## ORDERING INFORMATION<sup>1</sup>

6 x 6 mm (G, X, J, and H styles only)

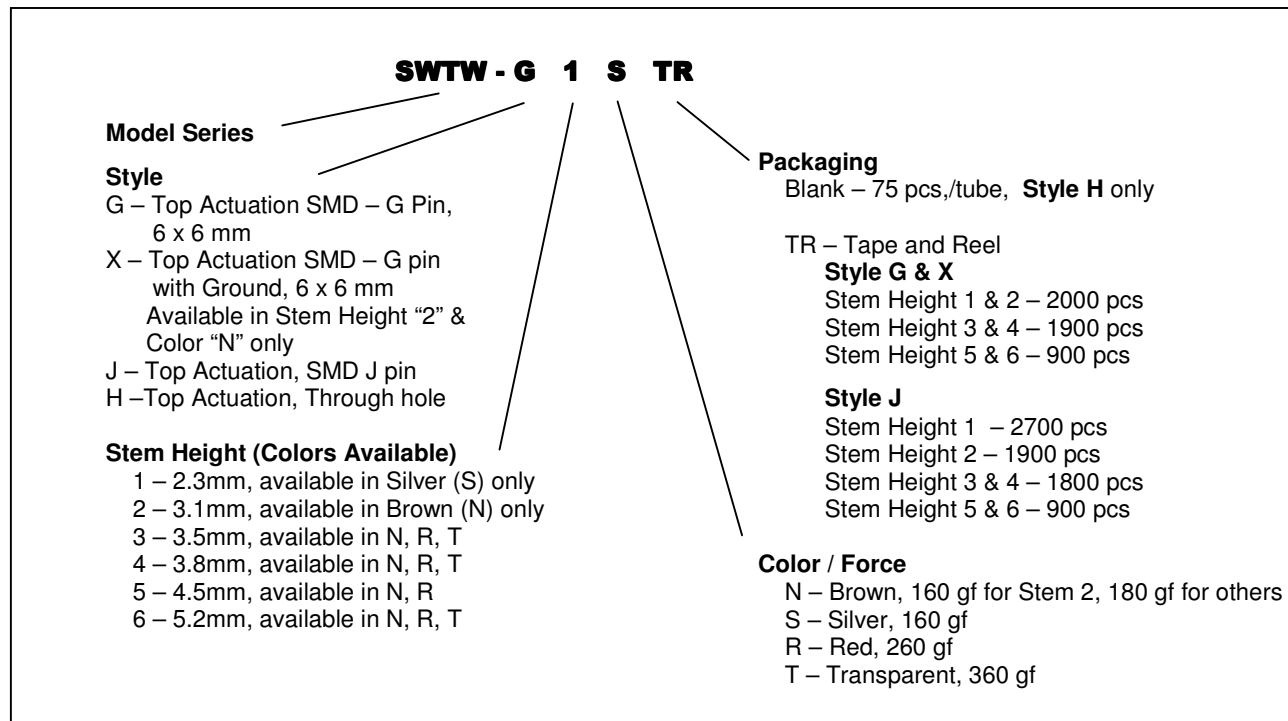

6 x 6 mm (S style only)

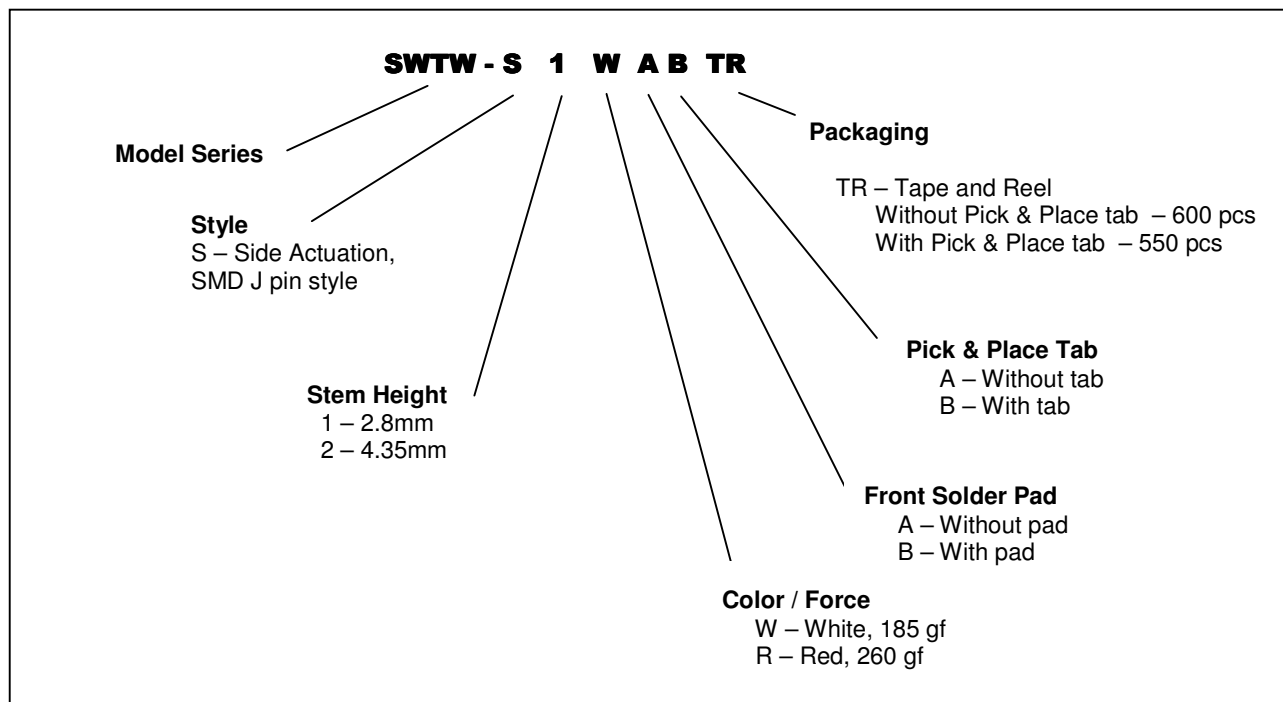

<sup>1</sup> Contact our customer service for custom designs and features.

# MODEL SWTW

## ORDERING INFORMATION

8 x 8 mm (R and K styles only)

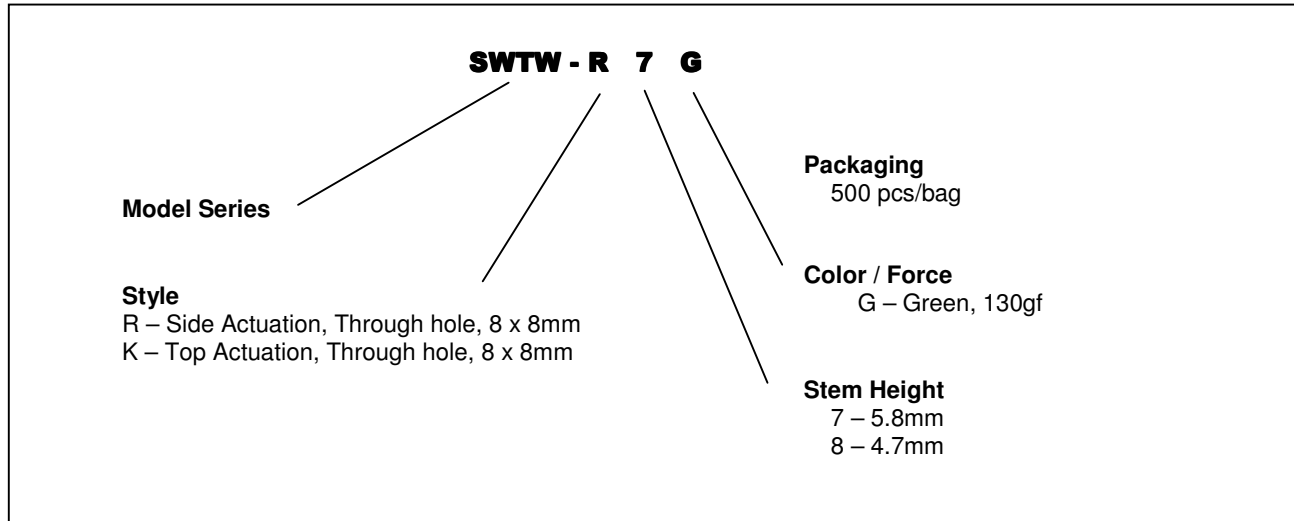

## OUTLINE DRAWINGS

Model SWTW-G (Top Actuation, SMD G pin style, 6 x 6 mm)

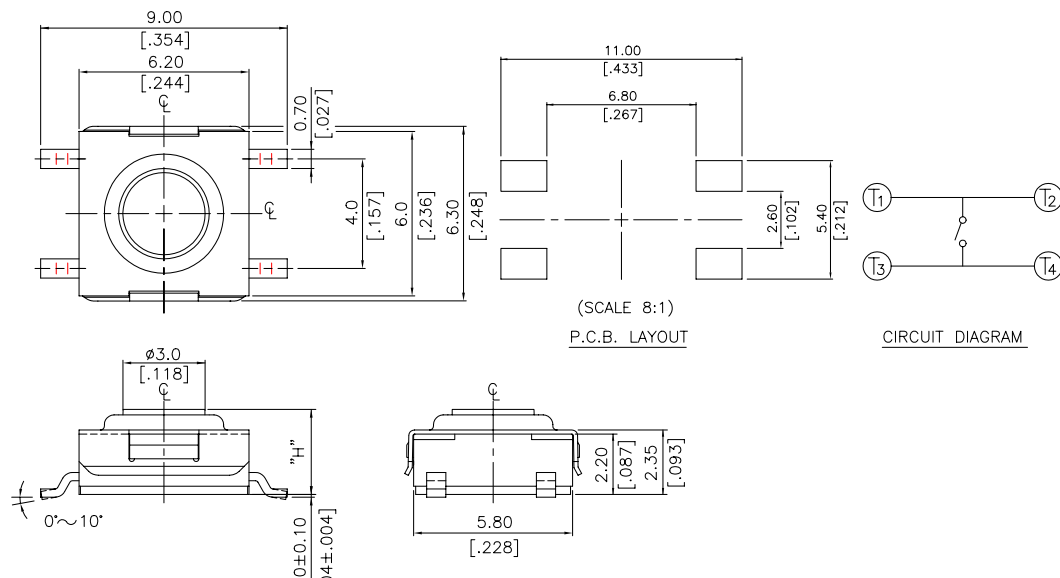

# MODEL SWTW

Model SWTW-X (Top Actuation, SMD G pin style with ground, 6 x 6 mm, Stem Height 2, H = 3.1 mm)

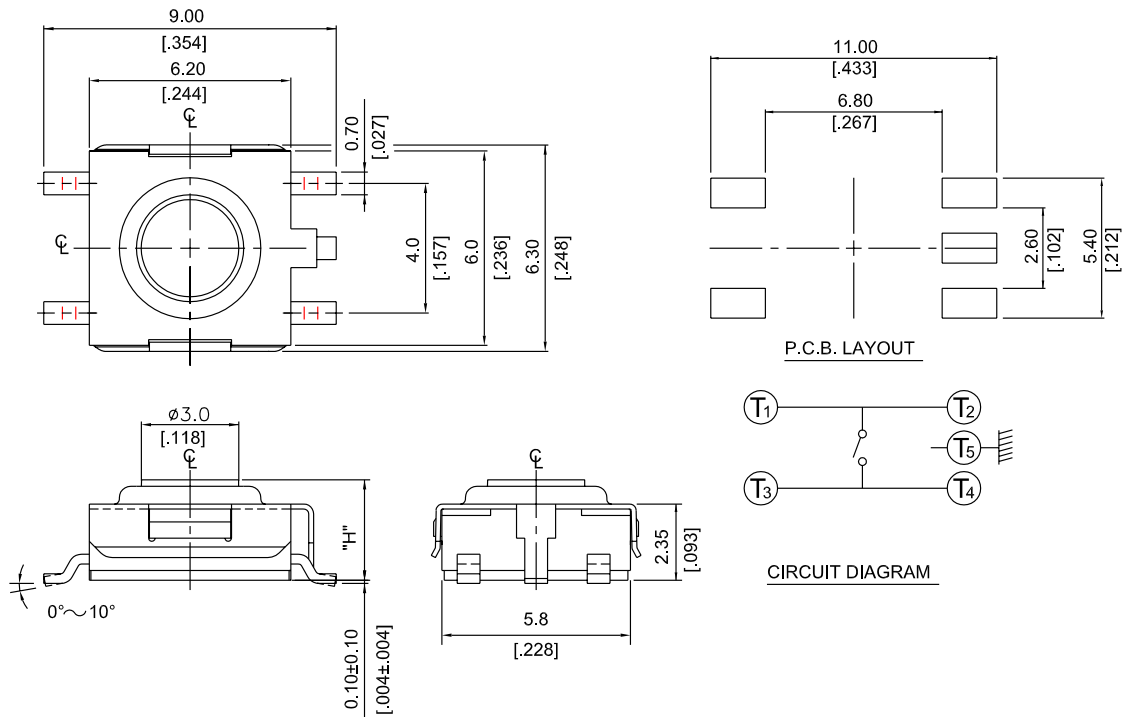

Model SWTW-J (Top Actuation, SMD J pin style, 6 x 6 mm)

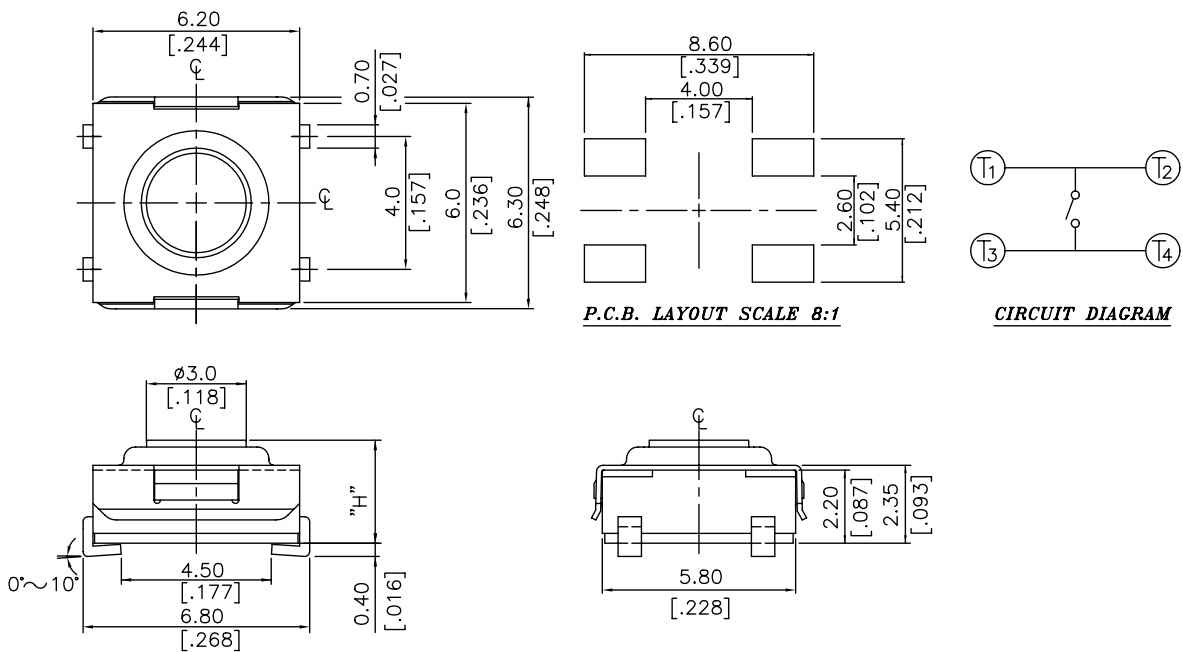

# MODEL SWTW

## Model SWTW-S (Side Actuation, SMD J pin style , 6 x 6 mm)

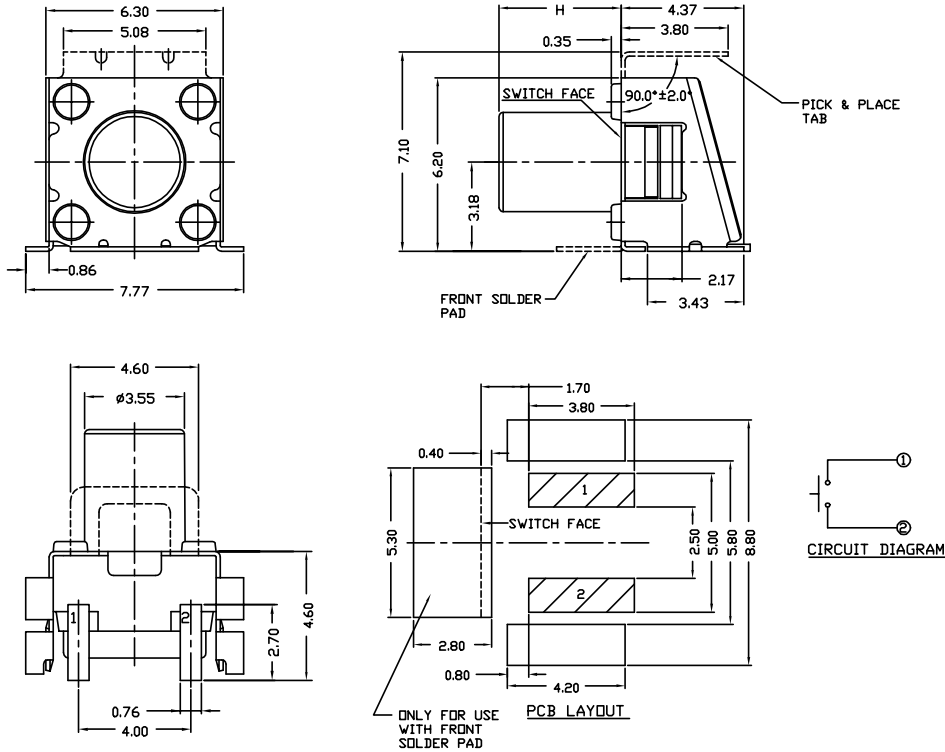

## Model SWTW-H (Top Actuation, Through hole, 6 x 6 mm)

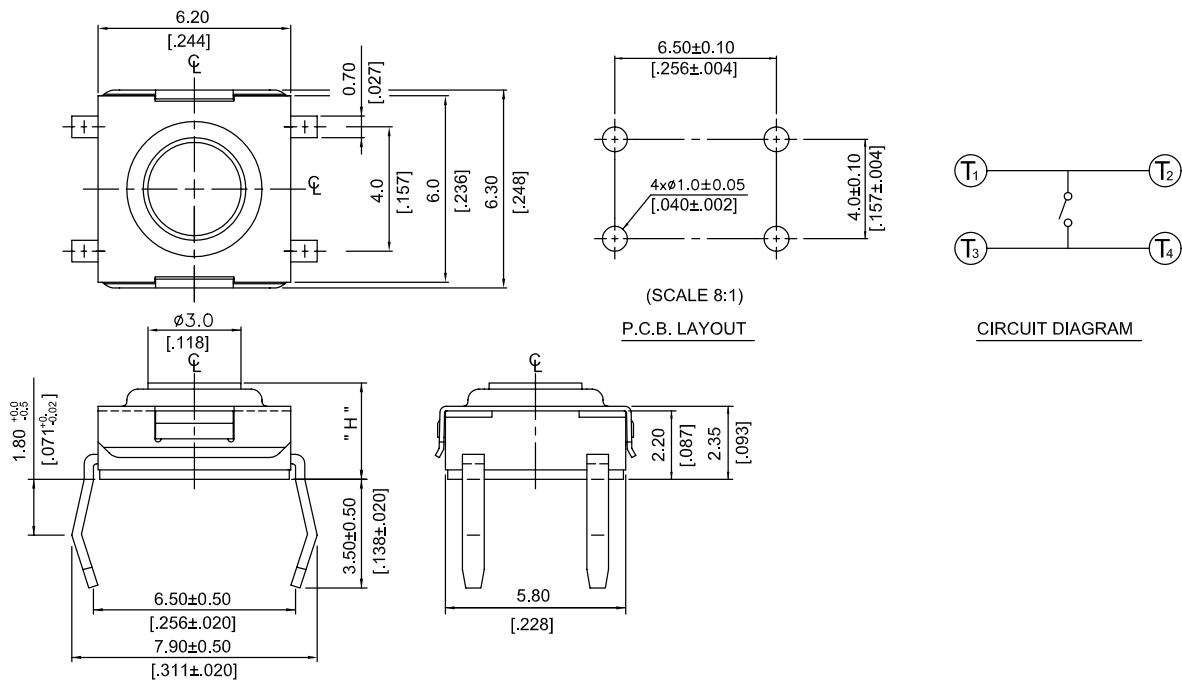

# MODEL SWTW

## Model SWTW-R (Side Actuation, Through hole, 8 x 8mm)

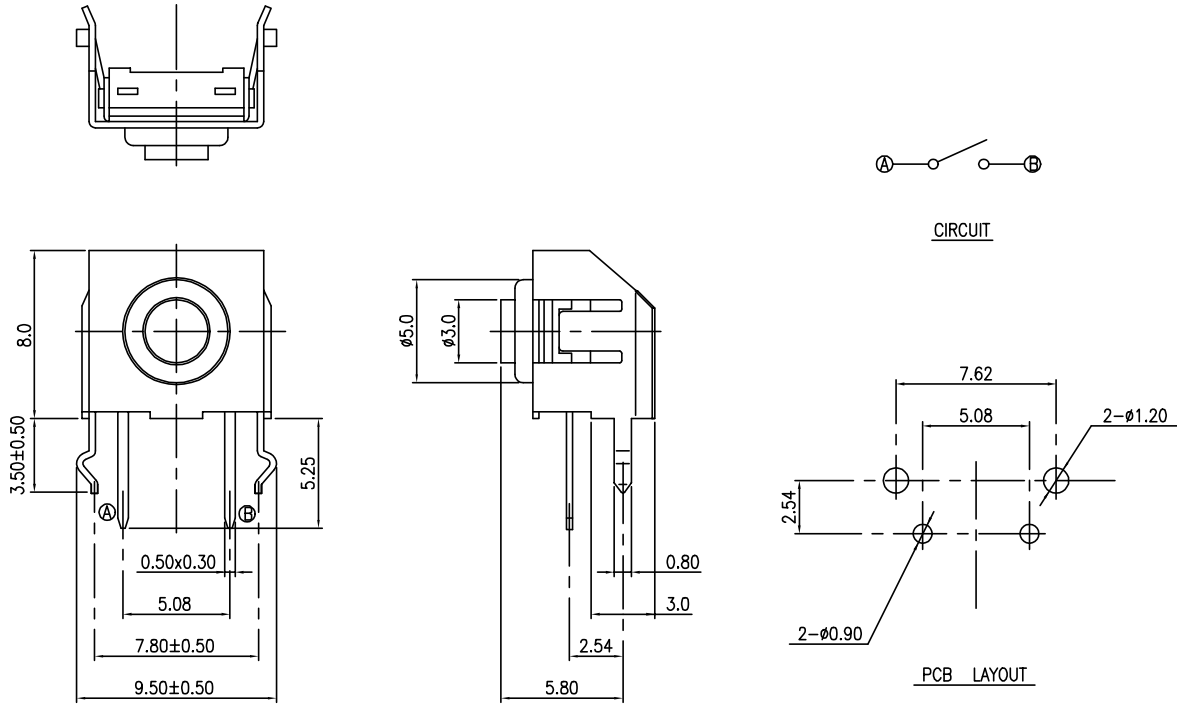

## Model SWTW-K (Top Actuation, Through hole, 8 x 8mm)

