

## SKAI Solutions

### 75V MOSFET Advanced Drive System

**SKAI 7001MD075 1452 W**  
SemiKron Advanced  
Integration (SKAI) module  
Liquid-cooled version

#### Features

- 75V Trench MOSFET technology on AIN DCB substrate
- Integrated DC-link electrolytic capacitors
- Pressure contact technology for improved power cycling performance
- Optimal thermal management with integrated liquid-cooled heatsink
- Two integrated current sensors with option to include three
- Integrated gate drive and power supply with under-voltage protection. 25-pin DB connector is standard on driver only versions
- Option to include an integrated controller based on TMS320LF2406ADSP. 14-pin AMP SEAL connector is standard on controller versions.

#### Typical Applications

- Automotive Starter Generator
- Hybrid Vehicles
- Fork Lifts
- Recreation Vehicles
- Fuel Cell Inverters

1) Contact SEMIKRON for power loss calculations

2) "r" referenced to built-in Temp. Sensor

3) 50% Water, 50% Glycol

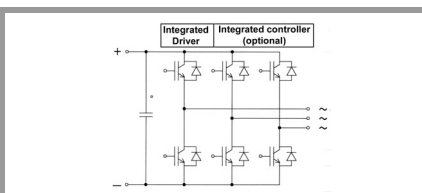

SKAI

Circuit	$I_{rms}$	$V_{dc}$	Types
B6Cl	500	60	SKAI 7001MD075 1452W

Symbol	Conditions	Values	Units
$I_{rms}^{1)}$	no overload, $T_{coolant}= 70^{\circ}C$ , 10kHz, p.f.=0,8	500	A
	overload, $t<20s$	700	A
$V_{(BR)DSS}$ $R_{DS(ON)}$	<b>MOSFET</b> driver without supply; min	75	V
	$V_{GS} = 10V$ , $T_j = 25^{\circ}C$	0,86	m $\Omega$
	$V_{GS} = 10V$ , $T_j = 125^{\circ}C$	1,25	m $\Omega$
$E_{ON} + E_{OFF}$	$V_{cc}= 50V$ , $I_D= 300A$ , $T_j= 125^{\circ}C$	6,7	mJ
$V_{SD}$	<b>Inverse diode</b> $I_F= 400A$ , $T_j = 25^{\circ}C$	0,98	V
	$I_F= 400A$ , $T_j = 125^{\circ}C$	0,9	V
$E_{ON} + E_{OFF}$	$V_{cc}= 50V$ , $I_F= 300A$ , $T_j= 125^{\circ}C$	1,46	mJ
$R_{thjr}^{2)}$	<b>Thermal Characteristics / Heatsink</b> per MOSFET switch	0,085	K/W
	$R_{thra}^{2)}$	Heatsink to coolant <sup>3)</sup> , flow rate $V_f= 15$ l/min	0,014
Heatsink to coolant <sup>3)</sup> , flow rate $V_f= 5$ l/min		0,020	K/W
$P_{aDR}$	Pressure drop, Coolant flow rate $V_f= 5$ l/min	0,08	bar
	Pressure drop, Coolant flow rate $V_f= 15$ l/min	0,61	bar
$C_{eqvl}$ $V_{DCmax}$	<b>Capacitor bank</b> total equivalent capacitance	29,7	mF
	max. DC voltage applied to capacitor bank	62	V
$V_s$	<b>Driver</b> Power supply: min	18	V
	Power supply: max	30	V
$I_s$	Supply current	500	mA
$f_{swmax}$	Max. Switching Frequency	20	kHz
$V_{isol}$	power terminals to heatsink: AC, 1 min.	1000	V
$T_{vj}$	Junction temperature (not including driver)	-40...+175	$^{\circ}C$
$T_{stg}$	Storage Temperature	-40...+125	$^{\circ}C$
$T_{amb}$	Operating ambient temperature	-40...+85	$^{\circ}C$
$I_{TRIPSC}$ $T_{TRIP}$ $U_{DCTRIP}$	<b>Protection</b> Short Circuit Protection	1200	A
	Over-Temp. Protection	115	$^{\circ}C$
	$V_{CC}$ Overvoltage Protection	63	V
L x W x H	<b>Dimensions</b> Length x Width x Height	315 x 115 x 95	mm
	w	approx.	3

# SEMISTACK - SKAI

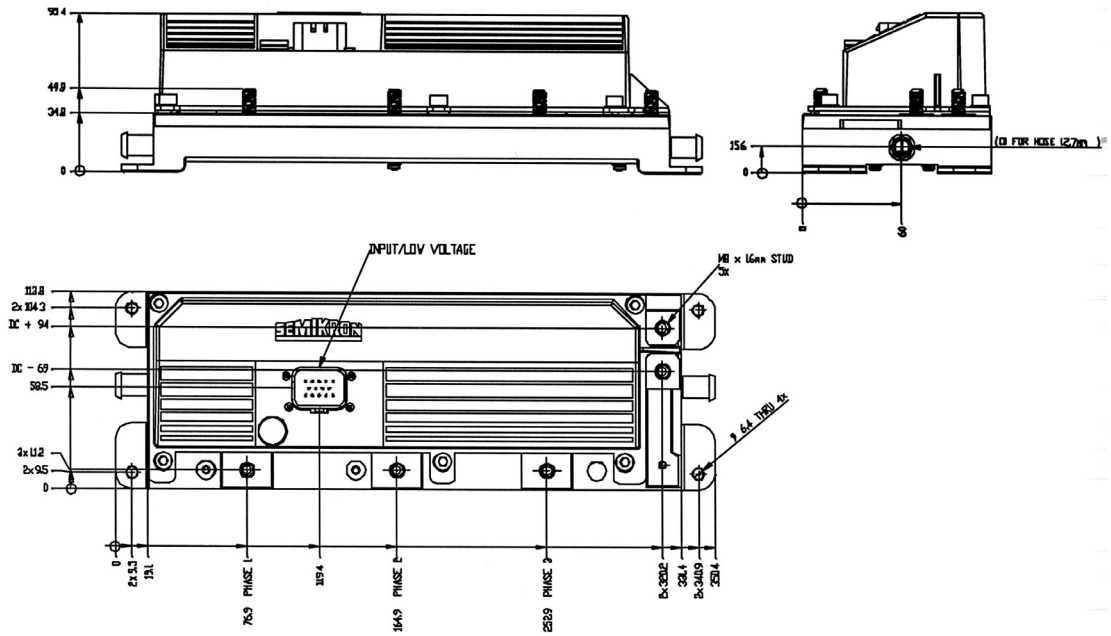

SKAI 7001MD075 1452 W: General dimensions

This technical information specifies semiconductor devices but promises no characteristics. No warranty or guarantee expressed or implied is made regarding delivery, performance or suitability.