

# R1Q2A3636/R1Q2A3618/R1Q2A3609

36-Mbit QDR™ II SRAM  
2-word Burst

REJ03C0294-0003

Preliminary

Rev. 0.03

Jul. 31, 2007

## Description

The R1Q2A3636 is a 1,048,576-word by 36-bit, the R1Q2A3618 is a 2,097,152-word by 18-bit, and the R1Q2A3609 is a 4,194,304-word by 9-bit synchronous quad data rate static RAM fabricated with advanced CMOS technology using full CMOS six-transistor memory cell. It integrates unique synchronous peripheral circuitry and a burst counter. All input registers controlled by an input clock pair (K and /K) and are latched on the positive edge of K and /K. These products are suitable for applications which require synchronous operation, high speed, low voltage, high density and wide bit configuration. These products are packaged in 165-pin plastic FBGA package.

## Features

- 1.8 V  $\pm$  0.1 V power supply for core ( $V_{DD}$ )
- 1.4 V to  $V_{DD}$  power supply for I/O ( $V_{DDQ}$ )
- DLL circuitry for wide output data valid window and future frequency scaling
- Separate independent read and write data ports with concurrent transactions
- 100% bus utilization DDR read and write operation
- Two-tick burst for low DDR transaction size
- Two input clocks (K and /K) for precise DDR timing at clock rising edges only
- Two output clocks (C and /C) for precise flight time and clock skew matching-clock and data delivered together to receiving device
- Internally self-timed write control
- Clock-stop capability with  $\mu$ s restart
- User programmable impedance output
- Fast clock cycle time: 4.0 ns (250 MHz)/5.0 ns (200 MHz)/6.0 ns (167 MHz)
- Simple control logic for easy depth expansion
- JTAG boundary scan

Notes: QDR RAMs and Quad Data Rate RAMs comprise a new family of products developed by Cypress Semiconductor, IDT, NEC, Samsung, and Renesas Technology Corp.

Preliminary: The specifications of this device are subject to change without notice. Please contact your nearest Renesas Technology's Sales Dept. regarding specifications.

## Ordering Information

Type No.	Organization	Cycle time	Clock frequency	Package	Notes
R1Q2A3636ABG-40R	1-M word × 36-bit	4.0 ns	250 MHz	Plastic FBGA 165-pin PLBG0165FB-A	
R1Q2A3636ABG-50R		5.0 ns	200 MHz		
R1Q2A3636ABG-60R		6.0 ns	167 MHz		
R1Q2A3618ABG-40R	2-M word × 18-bit	4.0 ns	250 MHz		
R1Q2A3618ABG-50R		5.0 ns	200 MHz		
R1Q2A3618ABG-60R		6.0 ns	167 MHz		
R1Q2A3609ABG-40R	4-M word × 9-bit	4.0 ns	250 MHz		
R1Q2A3609ABG-50R		5.0 ns	200 MHz		
R1Q2A3609ABG-60R		6.0 ns	167 MHz		

Notes: 1. Type No.

- (0:1) R1 : Renesas Memory prefix
- (2:3) Q2 : QDRII 2-word Burst SRAM  
Q3 : QDRII 4-word Burst SRAM  
Q4 : DDRII 2-word Burst SRAM  
Q5 : DDRII 4-word Burst SRAM  
Q6 : DDRII 2-word Burst SRAM Separate I/O
- (4) A :  $V_{DD}=1.8V$
- (5:6) 36 : Density = 36Mb  
72 : Density = 72Mb
- (7:8) 36 : Organization = x36  
18 : Organization = x18  
09 : Organization = x9

## Pin Arrangement

R1Q2A3636 series

	1	2	3	4	5	6	7	8	9	10	11
A	/CQ	$V_{SS}$	NC	/W	/BW2	/K	/BW1	/R	SA	NC	CQ
B	Q27	Q18	D18	SA	/BW3	K	/BW0	SA	D17	Q17	Q8
C	D27	Q28	D19	$V_{SS}$	SA	SA	SA	$V_{SS}$	D16	Q7	D8
D	D28	D20	Q19	$V_{SS}$	$V_{SS}$	$V_{SS}$	$V_{SS}$	$V_{SS}$	Q16	D15	D7
E	Q29	D29	Q20	$V_{DDQ}$	$V_{SS}$	$V_{SS}$	$V_{SS}$	$V_{DDQ}$	Q15	D6	Q6
F	Q30	Q21	D21	$V_{DDQ}$	$V_{DD}$	$V_{SS}$	$V_{DD}$	$V_{DDQ}$	D14	Q14	Q5
G	D30	D22	Q22	$V_{DDQ}$	$V_{DD}$	$V_{SS}$	$V_{DD}$	$V_{DDQ}$	Q13	D13	D5
H	/DOFF	$V_{REF}$	$V_{DDQ}$	$V_{DDQ}$	$V_{DD}$	$V_{SS}$	$V_{DD}$	$V_{DDQ}$	$V_{DDQ}$	$V_{REF}$	ZQ
J	D31	Q31	D23	$V_{DDQ}$	$V_{DD}$	$V_{SS}$	$V_{DD}$	$V_{DDQ}$	D12	Q4	D4
K	Q32	D32	Q23	$V_{DDQ}$	$V_{DD}$	$V_{SS}$	$V_{DD}$	$V_{DDQ}$	Q12	D3	Q3
L	Q33	Q24	D24	$V_{DDQ}$	$V_{SS}$	$V_{SS}$	$V_{SS}$	$V_{DDQ}$	D11	Q11	Q2
M	D33	Q34	D25	$V_{SS}$	$V_{SS}$	$V_{SS}$	$V_{SS}$	$V_{SS}$	D10	Q1	D2
N	D34	D26	Q25	$V_{SS}$	SA	SA	SA	$V_{SS}$	Q10	D9	D1
P	Q35	D35	Q26	SA	SA	C	SA	SA	Q9	D0	Q0
R	TDO	TCK	SA	SA	SA	/C	SA	SA	SA	TMS	TDI

(Top View)

**R1Q2A3618 series**

	1	2	3	4	5	6	7	8	9	10	11
A	/CQ	V <sub>SS</sub>	SA	/W	/BW1	/K	NC	/R	SA	NC	CQ
B	NC	Q9	D9	SA	NC	K	/BW0	SA	NC	NC	Q8
C	NC	NC	D10	V <sub>SS</sub>	SA	SA	SA	V <sub>SS</sub>	NC	Q7	D8
D	NC	D11	Q10	V <sub>SS</sub>	V <sub>SS</sub>	V <sub>SS</sub>	V <sub>SS</sub>	V <sub>SS</sub>	NC	NC	D7
E	NC	NC	Q11	V <sub>DDQ</sub>	V <sub>SS</sub>	V <sub>SS</sub>	V <sub>SS</sub>	V <sub>DDQ</sub>	NC	D6	Q6
F	NC	Q12	D12	V <sub>DDQ</sub>	V <sub>DD</sub>	V <sub>SS</sub>	V <sub>DD</sub>	V <sub>DDQ</sub>	NC	NC	Q5
G	NC	D13	Q13	V <sub>DDQ</sub>	V <sub>DD</sub>	V <sub>SS</sub>	V <sub>DD</sub>	V <sub>DDQ</sub>	NC	NC	D5
H	/DOFF	V <sub>REF</sub>	V <sub>DDQ</sub>	V <sub>DDQ</sub>	V <sub>DD</sub>	V <sub>SS</sub>	V <sub>DD</sub>	V <sub>DDQ</sub>	V <sub>DDQ</sub>	V <sub>REF</sub>	ZQ
J	NC	NC	D14	V <sub>DDQ</sub>	V <sub>DD</sub>	V <sub>SS</sub>	V <sub>DD</sub>	V <sub>DDQ</sub>	NC	Q4	D4
K	NC	NC	Q14	V <sub>DDQ</sub>	V <sub>DD</sub>	V <sub>SS</sub>	V <sub>DD</sub>	V <sub>DDQ</sub>	NC	D3	Q3
L	NC	Q15	D15	V <sub>DDQ</sub>	V <sub>SS</sub>	V <sub>SS</sub>	V <sub>SS</sub>	V <sub>DDQ</sub>	NC	NC	Q2
M	NC	NC	D16	V <sub>SS</sub>	V <sub>SS</sub>	V <sub>SS</sub>	V <sub>SS</sub>	V <sub>SS</sub>	NC	Q1	D2
N	NC	D17	Q16	V <sub>SS</sub>	SA	SA	SA	V <sub>SS</sub>	NC	NC	D1
P	NC	NC	Q17	SA	SA	C	SA	SA	NC	D0	Q0
R	TDO	TCK	SA	SA	SA	/C	SA	SA	SA	TMS	TDI

(Top View)

**R1Q2A3609 series**

	1	2	3	4	5	6	7	8	9	10	11
A	/CQ	V <sub>SS</sub>	SA	/W	NC	/K	NC	/R	SA	SA	CQ
B	NC	NC	NC	SA	NC	K	/BW	SA	NC	NC	Q4
C	NC	NC	NC	V <sub>SS</sub>	SA	SA	SA	V <sub>SS</sub>	NC	NC	D4
D	NC	D5	NC	V <sub>SS</sub>	V <sub>SS</sub>	V <sub>SS</sub>	V <sub>SS</sub>	V <sub>SS</sub>	NC	NC	NC
E	NC	NC	Q5	V <sub>DDQ</sub>	V <sub>SS</sub>	V <sub>SS</sub>	V <sub>SS</sub>	V <sub>DDQ</sub>	NC	D3	Q3
F	NC	NC	NC	V <sub>DDQ</sub>	V <sub>DD</sub>	V <sub>SS</sub>	V <sub>DD</sub>	V <sub>DDQ</sub>	NC	NC	NC
G	NC	D6	Q6	V <sub>DDQ</sub>	V <sub>DD</sub>	V <sub>SS</sub>	V <sub>DD</sub>	V <sub>DDQ</sub>	NC	NC	NC
H	/DOFF	V <sub>REF</sub>	V <sub>DDQ</sub>	V <sub>DDQ</sub>	V <sub>DD</sub>	V <sub>SS</sub>	V <sub>DD</sub>	V <sub>DDQ</sub>	V <sub>DDQ</sub>	V <sub>REF</sub>	ZQ
J	NC	NC	NC	V <sub>DDQ</sub>	V <sub>DD</sub>	V <sub>SS</sub>	V <sub>DD</sub>	V <sub>DDQ</sub>	NC	Q2	D2
K	NC	NC	NC	V <sub>DDQ</sub>	V <sub>DD</sub>	V <sub>SS</sub>	V <sub>DD</sub>	V <sub>DDQ</sub>	NC	NC	NC
L	NC	Q7	D7	V <sub>DDQ</sub>	V <sub>SS</sub>	V <sub>SS</sub>	V <sub>SS</sub>	V <sub>DDQ</sub>	NC	NC	Q1
M	NC	NC	NC	V <sub>SS</sub>	V <sub>SS</sub>	V <sub>SS</sub>	V <sub>SS</sub>	V <sub>SS</sub>	NC	NC	D1
N	NC	D8	NC	V <sub>SS</sub>	SA	SA	SA	V <sub>SS</sub>	NC	NC	NC
P	NC	NC	Q8	SA	SA	C	SA	SA	NC	D0	Q0
R	TDO	TCK	SA	SA	SA	/C	SA	SA	SA	TMS	TDI

(Top View)

Notes: 1. Address expansion order for future higher density SRAMs (i.e. 72Mb → 144Mb → 288Mb): (9A → 3A → 10A) → 2A → 7A → 5B.

## Pin Description

Name	I/O type	Descriptions	Notes
SA	Input	Synchronous address inputs: These inputs are registered and must meet the setup and hold times around the rising edge of K for READ cycles and must meet the setup and hold times around the rising edge of /K for WRITE cycles. All transactions operate on a burst-of-two words (one clock period of bus activity). These inputs are ignored when device is deselected.	
/R	Input	Synchronous read: When low, this input causes the address inputs to be registered and a READ cycle to be initiated. This input must meet setup and hold times around the rising edge of K.	
/W	Input	Synchronous write: When low, this input causes the address inputs to be registered and a WRITE cycle to be initiated. This input must meet setup and hold times around the rising edge of K.	
/BW <sub>x</sub>	Input	Synchronous byte writes: When low, these inputs cause their respective byte to be registered and written during WRITE cycles. These signals must meet setup and hold times around the rising edges of K and /K for each of the two rising edges comprising the WRITE cycle. See Byte Write Truth Table for signal to data relationship.	
K, /K	Input	Input clock: This input clock pair registers address and control inputs on the rising edge of K, and registers data on the rising edge of K and the rising edge of /K. /K is ideally 180 degrees out of phase with K. All synchronous inputs must meet setup and hold times around the clock rising edges. These balls cannot remain V <sub>REF</sub> level.	
C, /C	Input	Output clock: This clock pair provides a user-controlled means of tuning device output data. The rising edge of /C is used as the output timing reference for first output data. The rising edge of C is used as the output timing reference for second output data. Ideally, /C is 180 degrees out of phase with C. C and /C may be tied high to force the use of K and /K as the output reference clocks instead of having to provide C and /C clocks. If tied high, C and /C must remain high and not to be toggled during device operation. These balls cannot remain V <sub>REF</sub> level.	
/DOFF	Input	DLL disable: When low, this input causes the DLL to be bypassed for /DOFF Input stable, low frequency operation.	
ZQ	Input	Output impedance matching input: This input is used to tune the device outputs to the system data bus impedance. Q and CQ output impedance are set to $0.2 \times RQ$ , where RQ is a resistor from this ball to ground. This ball can be connected directly to V <sub>DDQ</sub> , which enables the minimum impedance mode. This ball cannot be connected directly to V <sub>SS</sub> or left unconnected.	
TMS TDI	Input	IEEE1149.1 test inputs: 1.8 V I/O levels. These balls may be left not TMS Input connected if the JTAG function is not used in the circuit.	
TCK	Input	IEEE1149.1 clock input: 1.8 V I/O levels. This ball must be tied to V <sub>SS</sub> if the JTAG function is not used TCK Input in the circuit.	
D <sub>0</sub> to D <sub>n</sub>	Input	Synchronous data inputs: Input data must meet setup and hold times around the rising edges of K and /K during WRITE operations. See Pin Arrangement figures for ball site location of individual signals. The ×9 device uses D0 to D8. Remaining signals are not used. The ×18 device uses D0 to D17. Remaining signals are not used. The ×36 device uses D0 to D35.	
CQ, /CQ	Output	Synchronous echo clock outputs: The edges of these outputs are tightly matched to the synchronous data outputs and can be used as a data valid indication. These signals run freely and do not stop when Q tristates.	
TDO	Output	IEEE 1149.1 test output: 1.8 V I/O level.	
Q <sub>0</sub> to Q <sub>n</sub>	Output	Synchronous data outputs: Output data is synchronized to the respective C and /C, or to the respective K and /K if C and /C are tied high. This bus operates in response to /R commands. See Pin Arrangement figures for ball site location of individual signals. The ×9 device uses Q0 to Q8. Remaining signals are not used. The ×18 device uses Q0 to Q17. Remaining signals are not used. The ×36 device uses Q0 to Q35.	

Name	I/O type	Descriptions	Notes
V <sub>DD</sub>	Supply	Power supply: 1.8 V nominal. See DC Characteristics and Operating V <sub>DD</sub> Supply Conditions for range.	
V <sub>DDQ</sub>	Supply	Power supply: Isolated output buffer supply. Nominally 1.5 V. 1.8 V is also permissible. See DC Characteristics and Operating Conditions for range.	
V <sub>SS</sub>	Supply	Power supply: Ground.	
V <sub>REF</sub>	—	HSTL input reference voltage: Nominally V <sub>DDQ</sub> /2, but may be adjusted to improve system noise margin. Provides a reference voltage for the HSTL input buffers.	
NC	—	No connect: These signals are not internally connected. These signals can be left floating or connected to ground to improve package heat dissipation.	

Notes: 1. All power supply and ground balls must be connected for proper operation of the device.

**Block Diagram (R1Q2A3636 / R1Q2A3618 / R1Q2A3609 series)**

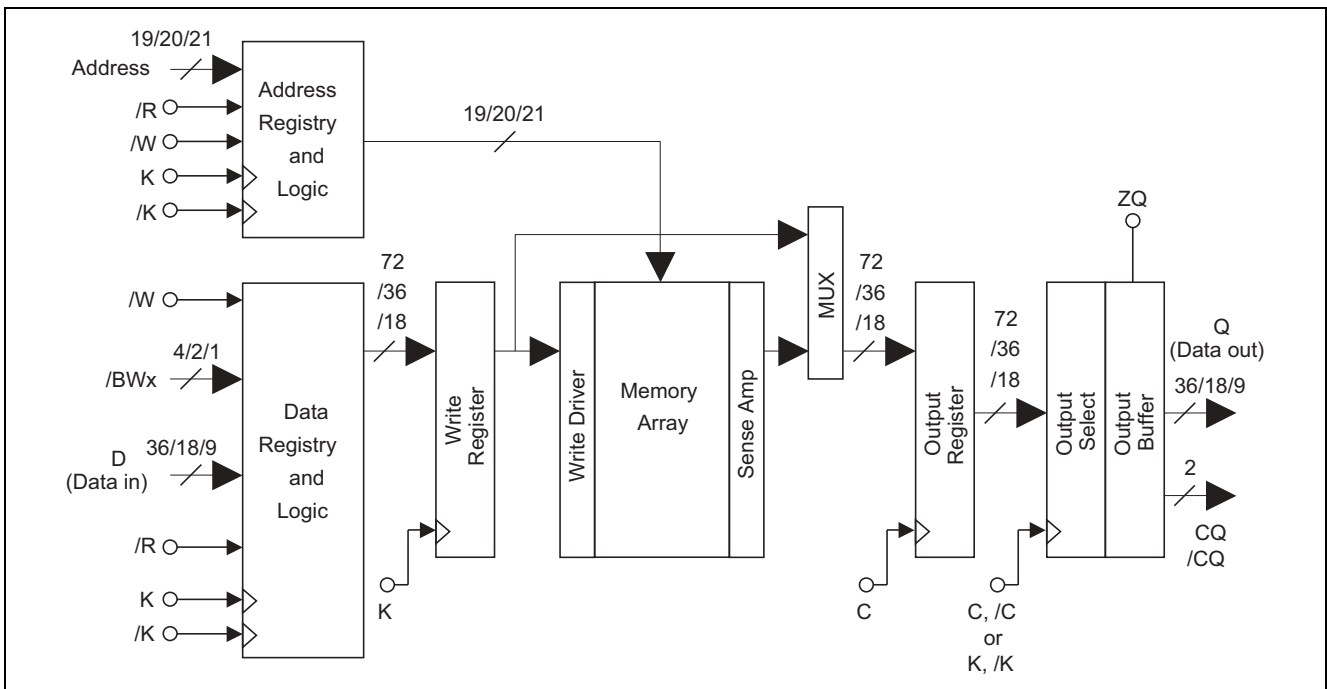

## General Description

### Power-up and Initialization Sequence

The following supply voltage application sequence is recommended:  $V_{SS}$ ,  $V_{DD}$ ,  $V_{DDQ}$ ,  $V_{REF}$  then  $V_{IN}$ .

After the stable power, there are three possible sequences.

1. Sequence when DLL disable (/DOFF pin fixed low)
  - Just after the stable power and clock (K, /K, C, /C), 1024 NOP cycles (min.) are required for all operations, including JTAG functions, to become normal.
- 2a. Sequence controlled by /DOFF pin when DLL enable
  - Just after the stable power and clock (K, /K, C, /C), take /DOFF to be high.
  - The additional 1024 NOP cycles (min.) are required to lock the DLL and for all operations to become normal.
- 2b. Sequence controlled by Clock (/DOFF pin fixed high) when DLL enable
  - If /DOFF pin is fixed high with unstable clock, the clock (K, /K, C, /C) must be stopped for 30ns (min.).
  - During stop clock stage, C pin must tie low for 30 ns (min.). C, /C, K and /K cannot remain  $V_{REF}$  level.
  - The additional 1024 NOP cycles (min.) are required to lock the DLL and for all operations to become normal.

- Notes:
1. After K or C clock is stopped, clock recovery cycles (1024 NOP cycles (min.)) are required for read/write operations to become normal.
  2. When DLL is enable and the operating frequency is changed, DLL reset should be required again. After DLL reset again, the 1024 NOP cycles (min.) are needed to lock the DLL.

#### 1. Sequence when DLL disable (/DOFF pin fixed low)

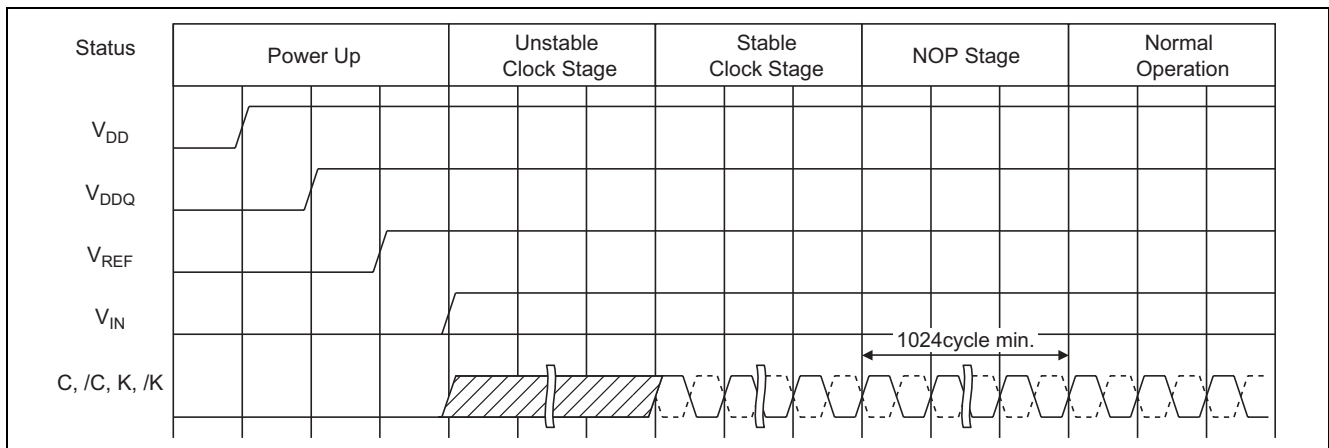

#### 2a. Sequence controlled by /DOFF pin when DLL enable

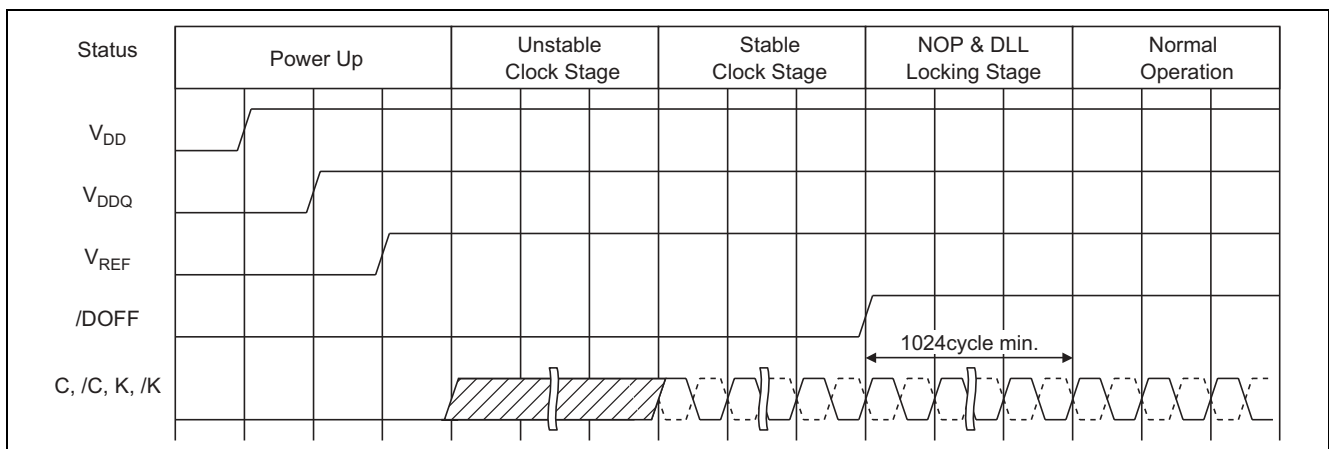

**2b. Sequence controlled by Clock (/DOFF pin fixed high) when DLL enable**

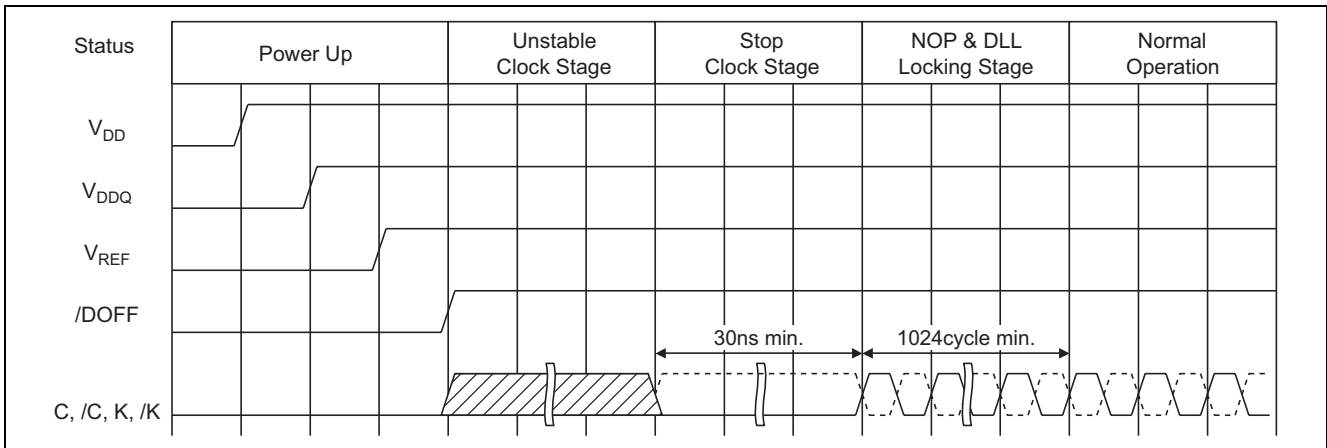

**DLL Constraints**

1. DLL uses either K or C clock as its synchronizing input, the input should have low phase jitter which is specified as TKC var.
2. The lower end of the frequency at which the DLL can operate is 100MHz.

**Programmable Output Impedance**

1. Output buffer impedance can be programmed by terminating the ZQ ball to V<sub>SS</sub> through a precision resistor (R<sub>Q</sub>). The value of R<sub>Q</sub> is five times the output impedance desired. The allowable range of R<sub>Q</sub> to guarantee impedance matching with a tolerance of 10% is 250 Ω typical.  
The total external capacitance of ZQ ball must be less than 7.5 pF.

## K Truth Table

Operation	K	/R	/W	D or Q		
Write Cycle: Load address, input write data on consecutive K and /K rising edges	↑	×	L	Data in		
				Input data	D(A+0)	D(A+1)
				Output clock	K(t)↑	/K(t)↑
Read Cycle: Load address, output read data on consecutive C and /C rising edges	↑	L	×	Data out		
				Output data	Q(A+0)	Q(A+1)
				Output clock	/C(t+1)↑	C(t+2)↑
NOP (No operation)	↑	H	H	D = × or Q = High-Z		
Standby (Clock stopped)	Stopped	×	×	Previous state		

Notes: 1. H: high level, L: low level, ×: don't care, ↑: rising edge.

2. Data inputs are registered at K and /K rising edges. Data outputs are delivered at C and /C rising edges, except if C and /C are high, then data outputs are delivered at K and /K rising edges.
3. /R and /W must meet setup/hold times around the rising edges (low to high) of K and are registered at the rising edge of K.
4. This device contains circuitry that will ensure the outputs will be in high-Z during power-up.
5. Refer to state diagram and timing diagrams for clarification.
6. When clocks are stopped, the following cases are recommended; the case of K = low, /K = high, C = low and /C = high, or the case of K = high, /K = low, C = high and /C = low. This condition is not essential, but permits most rapid restart by overcoming transmission line charging symmetrically.



**Byte Write Truth Table (x36)**

Operation	K	/K	/BW0	/BW1	/BW2	/BW3
Write D0 to D35	↑	—	L	L	L	L
	—	↑	L	L	L	L
Write D0 to D8	↑	—	L	H	H	H
	—	↑	L	H	H	H
Write D9 to D17	↑	—	H	L	H	H
	—	↑	H	L	H	H
Write D18 to D26	↑	—	H	H	L	H
	—	↑	H	H	L	H
Write D27 to D35	↑	—	H	H	H	L
	—	↑	H	H	H	L
Write nothing	↑	—	H	H	H	H
	—	↑	H	H	H	H

Notes: 1. H: high level, L: low level, ↑: rising edge.

2. Assumes a WRITE cycle was initiated. /BWx can be altered for any portion of the BURST WRITE operation provided that the setup and hold requirements are satisfied.

**Byte Write Truth Table (x18)**

Operation	K	/K	/BW0	/BW1
Write D0 to D17	↑	—	L	L
	—	↑	L	L
Write D0 to D8	↑	—	L	H
	—	↑	L	H
Write D9 to D17	↑	—	H	L
	—	↑	H	L
Write nothing	↑	—	H	H
	—	↑	H	H

Notes: 1. H: high level, L: low level, ↑: rising edge.

2. Assumes a WRITE cycle was initiated. /BWx can be altered for any portion of the BURST WRITE operation provided that the setup and hold requirements are satisfied.

**Byte Write Truth Table (x9)**

Operation	K	/K	/BW
Write D0 to D8	↑	—	L
	—	↑	L
Write nothing	↑	—	H
	—	↑	H

Notes: 1. H: high level, L: low level, ↑: rising edge.

2. Assumes a WRITE cycle was initiated. /BWx can be altered for any portion of the BURST WRITE operation provided that the setup and hold requirements are satisfied.

### Bus Cycle State Diagram

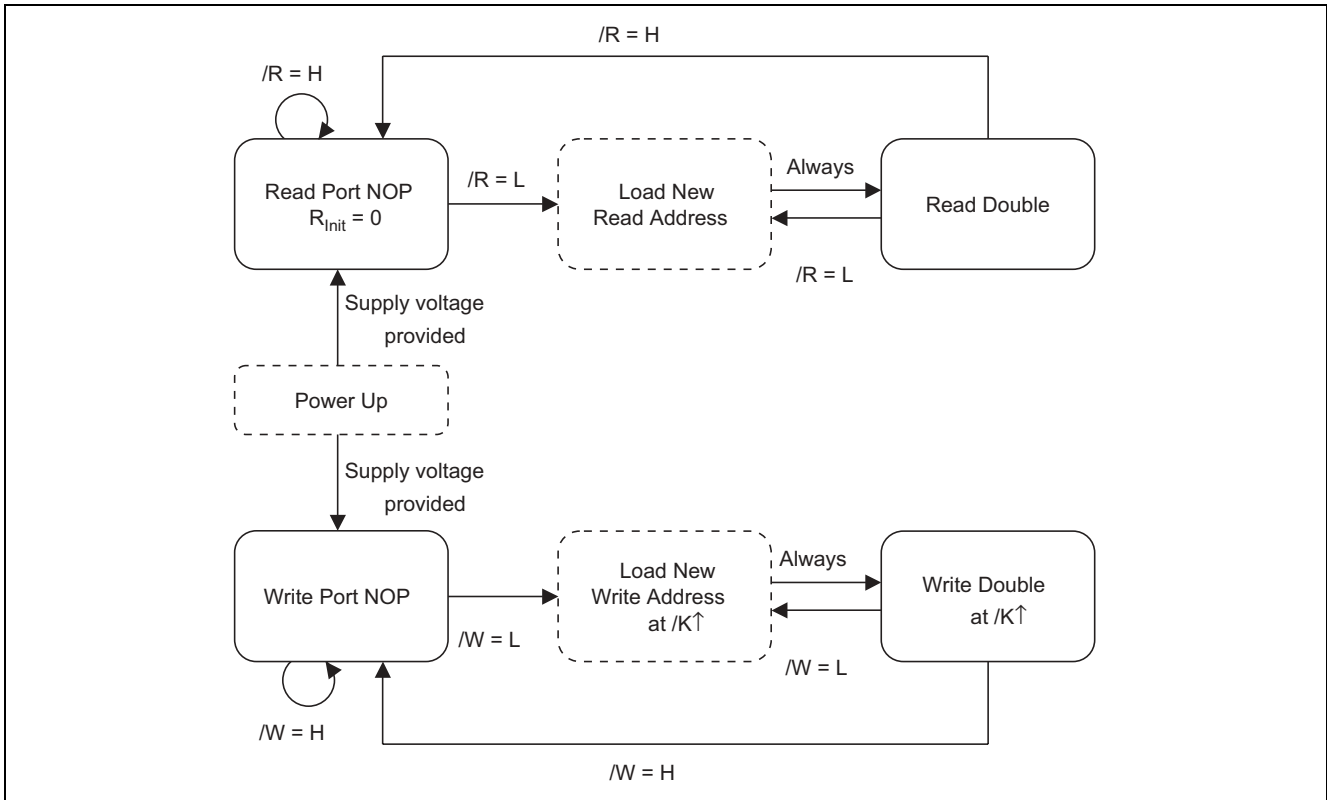

- Notes:
1. The address is concatenated with one additional internal LSB to facilitate burst operation. The address order is always fixed as: xxx...xxx+0, xxx...xxx+1.  
Bus cycle is terminated at the end of this sequence (burst count = 2).
  2. Read and write state machines can be active simultaneously.
  3. State machine control timing sequence is controlled by K.

## Absolute Maximum Ratings

Parameter	Symbol	Rating	Unit	Notes
Input voltage on any ball	$V_{IN}$	-0.5 to $V_{DD} + 0.5$ (2.5 V max.)	V	1, 4
Input/output voltage	$V_{I/O}$	-0.5 to $V_{DDQ} + 0.5$ (2.5 V max.)	V	1, 4
Core supply voltage	$V_{DD}$	-0.5 to 2.5	V	1, 4
Output supply voltage	$V_{DDQ}$	-0.5 to $V_{DD}$	V	1, 4
Junction temperature	$T_j$	+125 (max)	°C	
Storage temperature	$T_{STG}$	-55 to +125	°C	

Notes: 1. All voltage is referenced to  $V_{SS}$ .

- Permanent device damage may occur if Absolute Maximum Ratings are exceeded. Functional operation should be restricted the Operation Conditions. Exposure to higher than recommended voltages for extended periods of time could affect device reliability.
- These CMOS memory circuits have been designed to meet the DC and AC specifications shown in the tables after thermal equilibrium has been established.
- The following supply voltage application sequence is recommended:  $V_{SS}$ ,  $V_{DD}$ ,  $V_{DDQ}$ ,  $V_{REF}$  then  $V_{IN}$ . Remember, according to the Absolute Maximum Ratings table,  $V_{DDQ}$  is not to exceed 2.5 V, whatever the instantaneous value of  $V_{DDQ}$ .

## Recommended DC Operating Conditions

( $T_a = 0$  to +70°C)

Parameter	Symbol	Min	Typ	Max	Unit	Notes
Power supply voltage --core	$V_{DD}$	1.7	1.8	1.9	V	
Power supply voltage --I/O	$V_{DDQ}$	1.4	1.5	$V_{DD}$	V	
Input reference voltage --I/O	$V_{REF}$	0.68	0.75	0.95	V	1
Input high voltage	$V_{IH(DC)}$	$V_{REF} + 0.1$	—	$V_{DDQ} + 0.3$	V	2, 3
Input low voltage	$V_{IL(DC)}$	-0.3	—	$V_{REF} - 0.1$	V	2, 3

Notes: 1. Peak to peak AC component superimposed on  $V_{REF}$  may not exceed 5% of  $V_{REF}$ .

- Overshoot:  $V_{IH(AC)} \leq V_{DDQ} + 0.5$  V for  $t \leq t_{KHKH}/2$

Undershoot:  $V_{IL(AC)} \geq -0.5$  V for  $t \leq t_{KHKH}/2$

Power-up:  $V_{IH} \leq V_{DDQ} + 0.3$  V and  $V_{DD} \leq 1.7$  V and  $V_{DDQ} \leq 1.4$  V for  $t \leq 200$  ms

During normal operation,  $V_{DDQ}$  must not exceed  $V_{DD}$ .

Control input signals may not have pulse widths less than  $t_{KHKL}$  (min) or operate at cycle rates less than  $t_{KHKH}$  (min).

During normal operation,  $V_{IH(DC)}$  must not exceed  $V_{DDQ}$  and  $V_{IL(DC)}$  must not be lower than  $V_{SS}$ .

- These are DC test criteria. The AC  $V_{IH} / V_{IL}$  levels are defined separately to measure timing parameters.

## DC Characteristics

( $T_a = 0$  to +70°C,  $V_{DD} = 1.8V \pm 0.1V$ )

Parameter	Symbol	-40	-50	-60	Unit	Notes	
		Max	Max	Max			
Operating supply current (READ / WRITE)	(×9)	$I_{DD}$	600	550	500	mA	1, 2, 3
	(×18)	$I_{DD}$	650	600	550	mA	1, 2, 3
	(×36)	$I_{DD}$	700	650	600	mA	1, 2, 3
Standby supply current (NOP)	(×9 / ×18 / ×36)	$I_{SB1}$	350	340	330	mA	2, 4, 5

Parameter	Symbol	Min	Max	Unit	Test conditions	Notes
Input leakage current	$I_{LI}$	-2	2	$\mu\text{A}$		10
Output leakage current	$I_{LO}$	-5	5	$\mu\text{A}$		11
Output high voltage	$V_{OH} \text{ (Low)}$	$V_{DDQ} - 0.2$	$V_{DDQ}$	V	$ I_{OH}  \leq 0.1 \text{ mA}$	8, 9
	$V_{OH}$	$V_{DDQ}/2 - 0.08$	$V_{DDQ}/2 + 0.08$	V	Note 6	8, 9
Output low voltage	$V_{OL} \text{ (Low)}$	$V_{SS}$	0.2	V	$I_{OL} \leq 0.1 \text{ mA}$	8, 9
	$V_{OL}$	$V_{DDQ}/2 - 0.08$	$V_{DDQ}/2 + 0.08$	V	Note 7	8, 9

- Notes:
- All inputs (except ZQ,  $V_{REF}$ ) are held at either  $V_{IH}$  or  $V_{IL}$ .
  - $I_{OUT} = 0 \text{ mA}$ .  $V_{DD} = V_{DD} \text{ max}$ ,  $t_{KHKH} = t_{KHKH} \text{ min}$ .
  - Operating supply currents are measured at 100% bus utilization.
  - All address / data inputs are static at either  $V_{IN} > V_{IH}$  or  $V_{IN} < V_{IL}$ .
  - NOP currents are valid when entering NOP after all pending READ and WRITE cycles are completed.
  - Outputs are impedance-controlled.  $|I_{OH}| = (V_{DDQ}/2)/(RQ/5)$  for values of  $175 \Omega \leq RQ \leq 350 \Omega$ .
  - Outputs are impedance-controlled.  $I_{OL} = (V_{DDQ}/2)/(RQ/5)$  for values of  $175 \Omega \leq RQ \leq 350 \Omega$ .
  - AC load current is higher than the shown DC values. AC I/O curves are available upon request.
  - HSTL outputs meet JEDEC HSTL Class I standards.
  - $0 \leq V_{IN} \leq V_{DDQ}$  for all input balls (except  $V_{REF}$ , ZQ, TCK, TMS, TDI ball).
  - $0 \leq V_{OUT} \leq V_{DDQ}$  (except TDO ball), output disabled.

### Thermal Resistance

Parameter	Symbol	Typ	Unit	Notes
Junction to Ambient	$\theta_{JA}$	24.5	$^{\circ}\text{C/W}$	
Junction to Case	$\theta_{JC}$	5.6	$^{\circ}\text{C/W}$	

Note: These parameters are calculated under the condition of wind velocity = 1 m/s.

### Capacitance

( $T_a = +25^{\circ}\text{C}$ ,  $f = 1.0\text{MHz}$ ,  $V_{DD} = 1.8\text{V}$ ,  $V_{DDQ} = 1.5\text{V}$ )

Parameter	Symbol	Min	Typ	Max	Unit	Test conditions	Notes
Input capacitance	$C_{IN}$	—	2	3	pF	$V_{IN} = 0 \text{ V}$	1, 2
Clock input capacitance	$C_{CLK}$	—	2	3	pF	$V_{CLK} = 0 \text{ V}$	1, 2
Input/output capacitance (D, Q, ZQ)	$C_{I/O}$	—	3	4.5	pF	$V_{I/O} = 0 \text{ V}$	1, 2

- Notes:
- These parameters are sampled and not 100% tested.
  - Except JTAG (TCK, TMS, TDI, TDO) pins.

### AC Test Conditions

( $T_a = 0 \text{ to } +70^{\circ}\text{C}$ ,  $V_{DD} = 1.8\text{V} \pm 0.1\text{V}$ )

#### Input waveform (Rise/fall time $\leq 0.3 \text{ ns}$ )

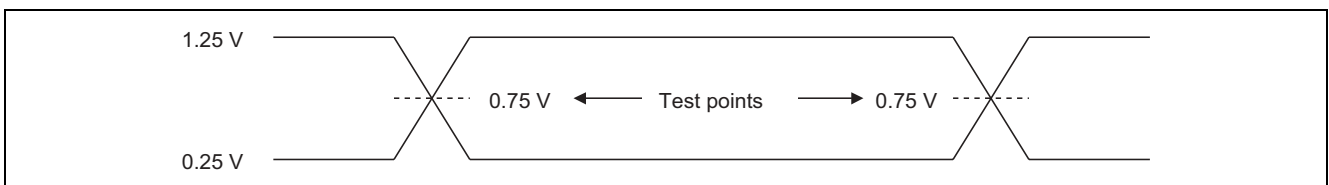

**Output waveform**

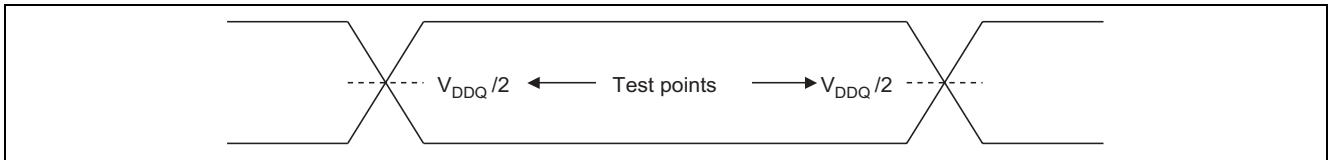

**Output load condition**

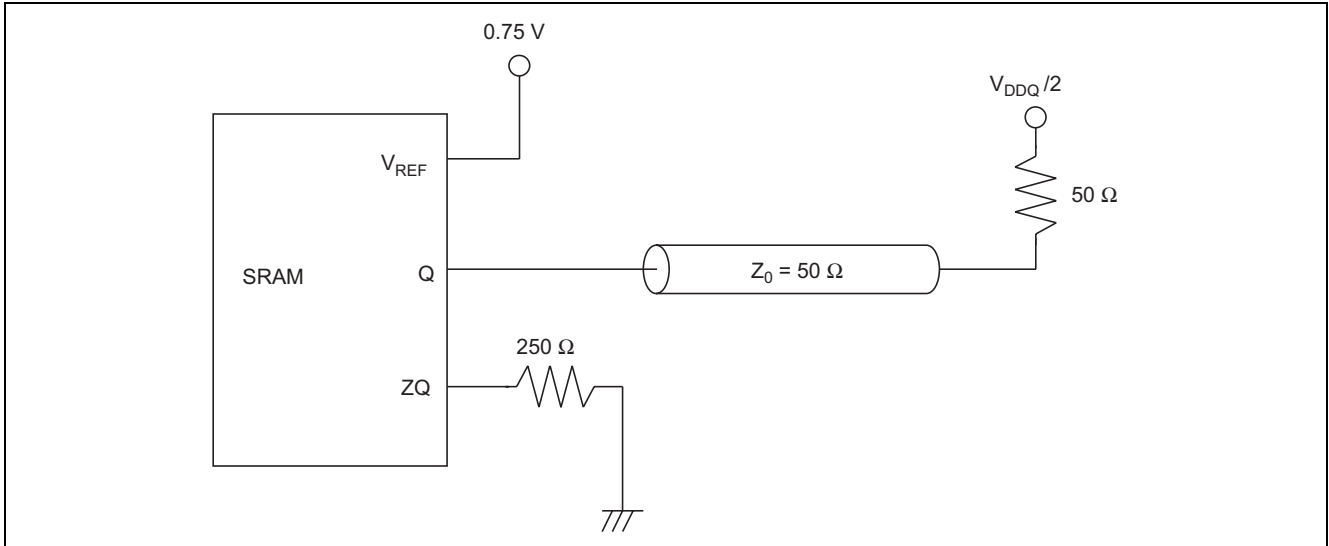

**AC Operating Conditions**

Parameter	Symbol	Min	Typ	Max	Unit	Notes
Input high voltage	$V_{IH(AC)}$	$V_{REF} + 0.2$	—	—	V	1, 2, 3, 4
Input low voltage	$V_{IL(AC)}$	—	—	$V_{REF} - 0.2$	V	1, 2, 3, 4

Notes: 1. All voltages referenced to  $V_{SS}$  (GND).

2. These conditions are for AC functions only, not for AC parameter test.

3. Overshoot:  $V_{IH(AC)} \leq V_{DDQ} + 0.5 \text{ V}$  for  $t \leq t_{KHKH}/2$

Undershoot:  $V_{IL(AC)} \geq -0.5 \text{ V}$  for  $t \leq t_{KHKH}/2$

Power-up:  $V_{IH} \leq V_{DDQ} + 0.3 \text{ V}$  and  $V_{DD} \leq 1.7 \text{ V}$  and  $V_{DDQ} \leq 1.4 \text{ V}$  for  $t \leq 200 \text{ ms}$

During normal operation,  $V_{DDQ}$  must not exceed  $V_{DD}$ . Control input signals may not have pulse widths less than  $t_{KHKL}$  (min) or operate at cycle rates less than  $t_{KHKH}$  (min).

4. To maintain a valid level, the transitioning edge of the input must:

a. Sustain a constant slew rate from the current AC level through the target AC level,  $V_{IL(AC)}$  or  $V_{IH(AC)}$ .

b. Reach at least the target AC level.

c. After the AC target level is reached, continue to maintain at least the target DC level,  $V_{IL(DC)}$  or  $V_{IH(DC)}$ .

## AC Characteristics

(Ta = 0 to +70°C, V<sub>DD</sub> = 1.8V ± 0.1V)

Parameter	Symbol	-40		-50		-60		Unit	Notes
		Min	Max	Min	Max	Min	Max		
Average clock cycle time (K, /K, C, /C)	t <sub>KHKH</sub>	4.00	5.25	5.00	6.30	6.00	8.00	ns	
Clock phase jitter (K, /K, C, /C)	t <sub>KC var</sub>	—	0.20	—	0.20	—	0.20	ns	3
Clock high time (K, /K, C, /C)	t <sub>KHKL</sub>	1.60	—	2.00	—	2.40	—	ns	
Clock low time (K, /K, C, /C)	t <sub>KLKH</sub>	1.60	—	2.00	—	2.40	—	ns	
Clock to /clock (K to /K, C to /C)	t <sub>KH/KH</sub>	1.80	—	2.20	—	2.70	—	ns	
/Clock to clock (/K to K, /C to C)	t <sub>/KH/KH</sub>	1.80	—	2.20	—	2.70	—	ns	
Clock to data clock (K to C, /K to /C)	t <sub>KHCH</sub>	0	1.10	0	1.60	0	2.10	ns	
DLL lock time (K, C)	t <sub>KC lock</sub>	1,024	—	1,024	—	1,024	—	Cycle	2
K static to DLL reset	t <sub>KC reset</sub>	30	—	30	—	30	—	ns	7
C, /C high to output valid	t <sub>CHQV</sub>	—	0.45	—	0.45	—	0.50	ns	
C, /C high to output hold	t <sub>CHQX</sub>	-0.45	—	-0.45	—	-0.50	—	ns	
C, /C high to echo clock valid	t <sub>CHCQV</sub>	—	0.45	—	0.45	—	0.50	ns	
C, /C high to echo clock hold	t <sub>CHCQX</sub>	-0.45	—	-0.45	—	-0.50	—	ns	
CQ, /CQ high to output valid	t <sub>CQHCV</sub>	—	0.30	—	0.35	—	0.40	ns	4, 7
CQ, /CQ high to output hold	t <sub>CQHCV</sub>	-0.30	—	-0.35	—	-0.40	—	ns	4, 7
C, /C high to output high-Z	t <sub>CHQZ</sub>	—	0.45	—	0.45	—	0.50	ns	5
C, /C high to output low-Z	t <sub>CHQX1</sub>	-0.45	—	-0.45	—	-0.50	—	ns	5
Address valid to K, /K rising edge	t <sub>AVKH</sub>	0.35	—	0.40	—	0.50	—	ns	1
Control inputs valid to K rising edge	t <sub>IVKH</sub>	0.35	—	0.40	—	0.50	—	ns	1
Data-in valid to K, /K rising edge	t <sub>DVKH</sub>	0.35	—	0.40	—	0.50	—	ns	1
K, /K rising edge to address hold	t <sub>KHAX</sub>	0.35	—	0.40	—	0.50	—	ns	1
K, /K rising edge to control inputs hold	t <sub>KHIX</sub>	0.35	—	0.40	—	0.50	—	ns	1
K, /K rising edge to data-in hold	t <sub>KHDX</sub>	0.35	—	0.40	—	0.50	—	ns	1

- Notes:
1. This is a synchronous device. All addresses, data and control lines must meet the specified setup and hold times for all latching clock edges.
  2. V<sub>DD</sub> slew rate must be less than 0.1 V DC per 50 ns for DLL lock retention. DLL lock time begins once V<sub>DD</sub> and input clock are stable. It is recommended that the device is kept inactive during these cycles.
  3. Clock phase jitter is the variance from clock rising edge to the next expected clock rising edge.
  4. Echo clock is very tightly controlled to data valid / data hold. By design, there is a ±0.1 ns variation from echo clock to data. The datasheet parameters reflect tester guardbands and test setup variations.
  5. Transitions are measured ±100 mV from steady-state voltage.
  6. At any given voltage and temperature t<sub>CHQZ</sub> is less than t<sub>CHQX1</sub> and t<sub>CHQZ</sub> less than t<sub>CHQV</sub>.
  7. These parameters are sampled.

## Remarks:

1. Test conditions as specified with the output loading as shown in AC Test Conditions unless otherwise noted.
2. Control input signals may not be operated with pulse widths less than t<sub>KHKL</sub> (min).
3. If C, /C are tied high, K, /K become the references for C, /C timing parameters.
4. V<sub>DDQ</sub> is +1.5 V DC.
5. Control signals are /R, /W, /BW, /BW0, /BW1, /BW2 and /BW3.  
BWn signals must operate at the same timing as Data in.
6. t<sub>CHQV</sub>, t<sub>CHCQV</sub> are 0.65 ns and t<sub>CHQX</sub>, t<sub>CHCQX</sub> are -0.65 ns on R1Q2A3636ABG (-40R, -50R) devices.

# Timing Waveforms

## Read and Write Timing

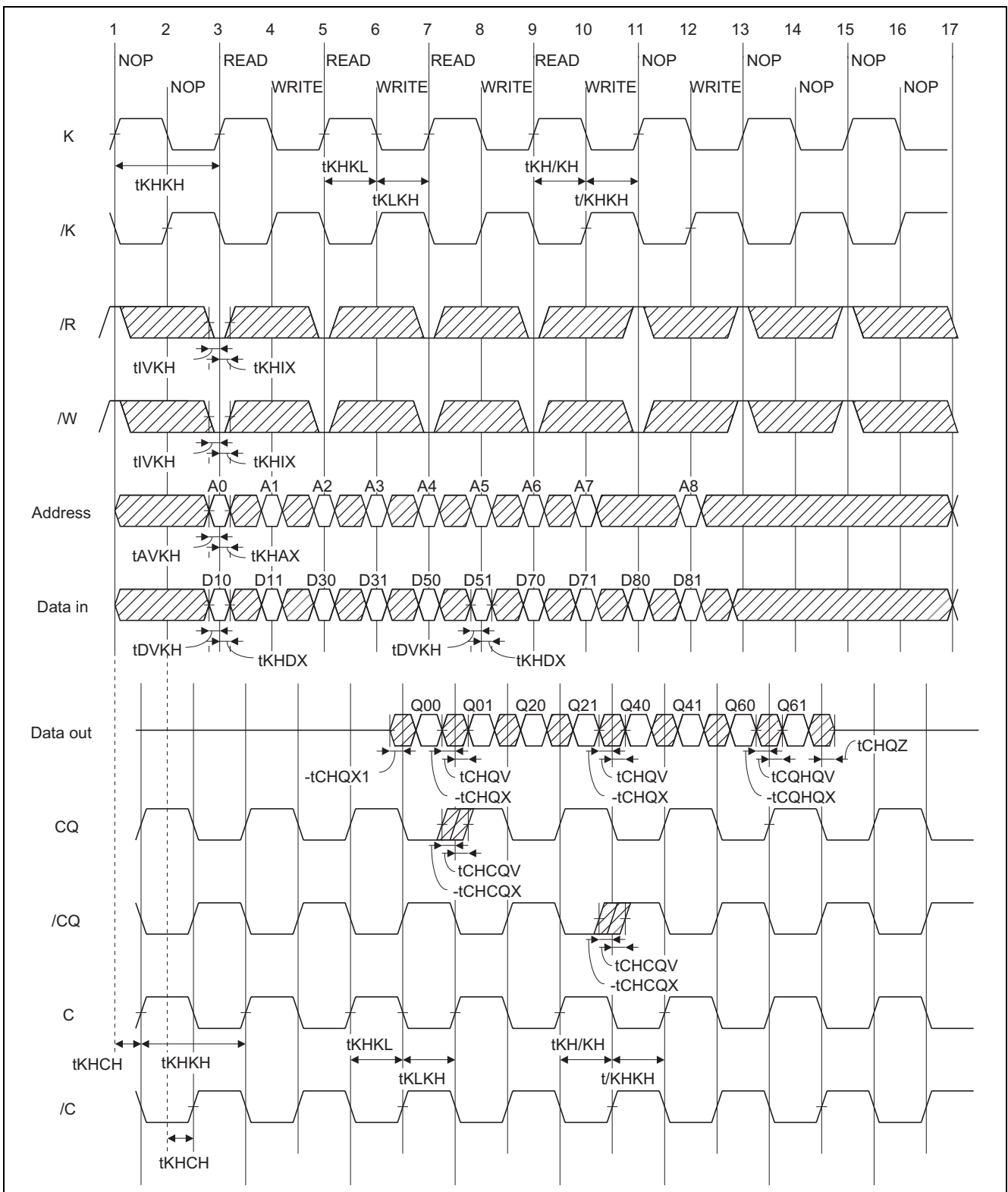

- Notes:
1. Q00 refers to output from address A0+0. Q01 refers to output from the next internal burst address following A0, i.e., A0+1.
  2. Outputs are disable (high-Z) one clock cycle after a NOP.
  3. In this example, if address A0 = A1, then data Q00 = D10, Q01 = D11. Write data is forwarded immediately as read results.
  4. To control read and write operations, /BW signals must operate at the same timing as Data in.

## JTAG Specification

These products support a limited set of JTAG functions as in IEEE standard 1149.1.

### Disabling the Test Access Port

It is possible to use this device without utilizing the TAP. To disable the TAP controller without interfering with normal operation of the device, TCK must be tied to  $V_{SS}$  to preclude mid level inputs. TDI and TMS are designed so an undriven input will produce a response identical to the application of a logic 1, and may be left unconnected. But they may also be tied to  $V_{DD}$  through a 1k $\Omega$  resistor. TDO should be left unconnected.

### Test Access Port (TAP) Pins

Symbol I/O	Pin assignments	Description	Notes
TCK	2R	Test clock input. All inputs are captured on the rising edge of TCK and all outputs propagate from the falling edge of TCK.	
TMS	10R	Test mode select. This is the command input for the TAP controller state machine.	
TDI	11R	Test data input. This is the input side of the serial registers placed between TDI and TDO. The register placed between TDI and TDO is determined by the state of the TAP controller state machine and the instruction that is currently loaded in the TAP instruction.	
TDO	1R	Test data output. Output changes in response to the falling edge of TCK. This is the output side of the serial registers placed between TDI and TDO.	

Notes: The device does not have TRST (TAP reset). The Test-Logic Reset state is entered while TMS is held high for five rising edges of TCK. The TAP controller state is also reset on SRAM POWER-UP.

### TAP DC Operating Characteristics

( $T_a = 0$  to  $+70^\circ\text{C}$ ,  $V_{DD} = 1.8\text{V} \pm 0.1\text{V}$ )

Parameter	Symbol	Min	Typ	Max	Unit	Notes
Input high voltage	$V_{IH}$	+1.3	—	$V_{DD} + 0.3$	V	
Input low voltage	$V_{IL}$	-0.3	—	+0.5	V	
Input leakage current	$I_{LI}$	-5.0	—	+5.0	$\mu\text{A}$	$0\text{V} \leq V_{IN} \leq V_{DD}$
Output leakage current	$I_{LO}$	-5.0	—	+5.0	$\mu\text{A}$	$0\text{V} \leq V_{IN} \leq V_{DD}$ , output disabled
Output low voltage	$V_{OL1}$	—	—	0.2	V	$I_{OLC} = 100\ \mu\text{A}$
	$V_{OL2}$	—	—	0.4	V	$I_{OLT} = 2\ \text{mA}$
Output high voltage	$V_{OH1}$	1.6	—	—	V	$ I_{OHC}  = 100\ \mu\text{A}$
	$V_{OH2}$	1.4	—	—	V	$ I_{OHT}  = 2\ \text{mA}$

- Notes: 1. All voltages referenced to  $V_{SS}$  (GND).  
 2. Power-up:  $V_{IH} \leq V_{DDQ} + 0.3\ \text{V}$  and  $V_{DD} \leq +1.7\ \text{V}$  and  $V_{DDQ} \leq +1.4\ \text{V}$  for  $t \leq 200\ \text{ms}$ .  
 3. In "EXTEST" mode and "SAMPLE" mode,  $V_{DDQ}$  is nominally 1.5 V.  
 4. ZQ:  $V_{IH} = V_{DDQ}$ .



### TAP AC Test Conditions

Parameter	Symbol	Conditions	Unit	Notes
Temperature	$T_a$	$0 \leq T_a \leq +70$	°C	
Input timing measurement reference levels	$V_{REF}$	0.9	V	
Input pulse levels	$V_{IL}, V_{IH}$	0 to 1.8	V	
Input rise/fall time	$t_r, t_f$	$\leq 1.0$	ns	
Output timing measurement reference levels		0.9	V	
Test load termination supply voltage ( $V_{TT}$ )		0.9	V	
Output load		See figures		

#### Input waveform

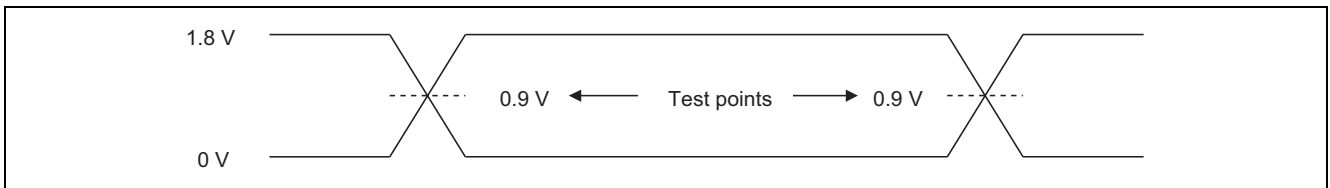

#### Output waveform

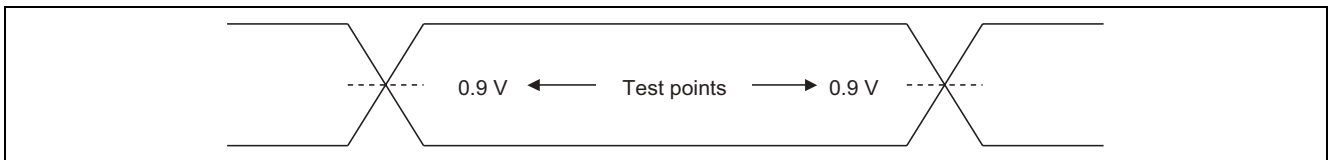

#### Output load condition

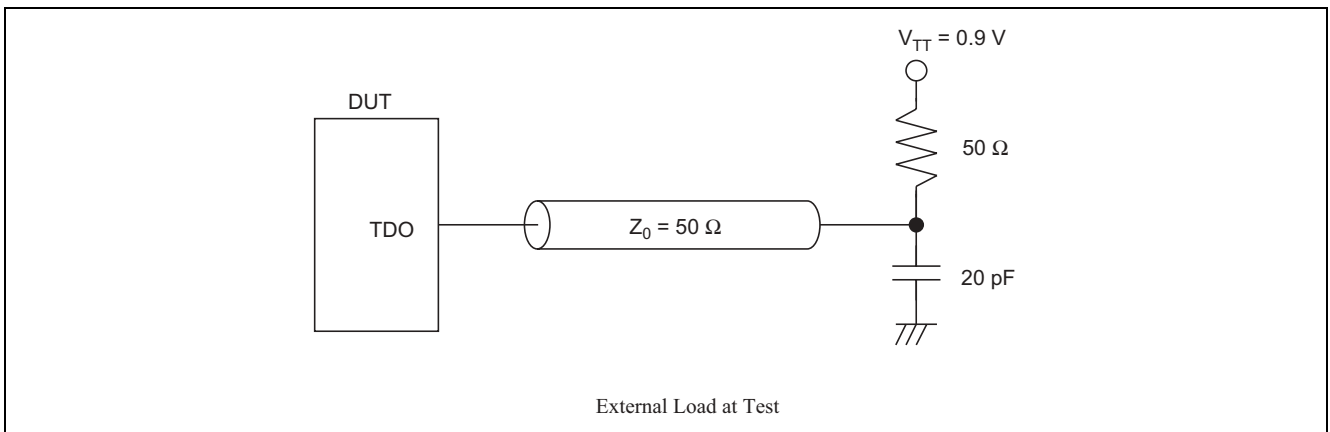

### TAP AC Operating Characteristics

( $T_a = 0$  to  $+70^\circ\text{C}$ ,  $V_{DD} = 1.8\text{V} \pm 0.1\text{V}$ )

Parameter	Symbol	Min	Typ	Max	Unit	Notes
Test clock (TCK) cycle time	$t_{\text{THTH}}$	100	—	—	ns	
TCK high pulse width	$t_{\text{THTL}}$	40	—	—	ns	
TCK low pulse width	$t_{\text{TLTH}}$	40	—	—	ns	
Test mode select (TMS) setup	$t_{\text{MVTH}}$	10	—	—	ns	
TMS hold	$t_{\text{THMX}}$	10	—	—	ns	
Capture setup	$t_{\text{CS}}$	10	—	—	ns	1
Capture hold	$t_{\text{CH}}$	10	—	—	ns	1
TDI valid to TCK high	$t_{\text{DVTH}}$	10	—	—	ns	
TCK high to TDI invalid	$t_{\text{THDX}}$	10	—	—	ns	
TCK low to TDO unknown	$t_{\text{TLQX}}$	0	—	—	ns	
TCK low to TDO valid	$t_{\text{TLQV}}$	—	—	20	ns	

Notes: 1.  $t_{\text{CS}} + t_{\text{CH}}$  defines the minimum pause in RAM I/O pad transitions to assure pad data capture.

### TAP Controller Timing Diagram

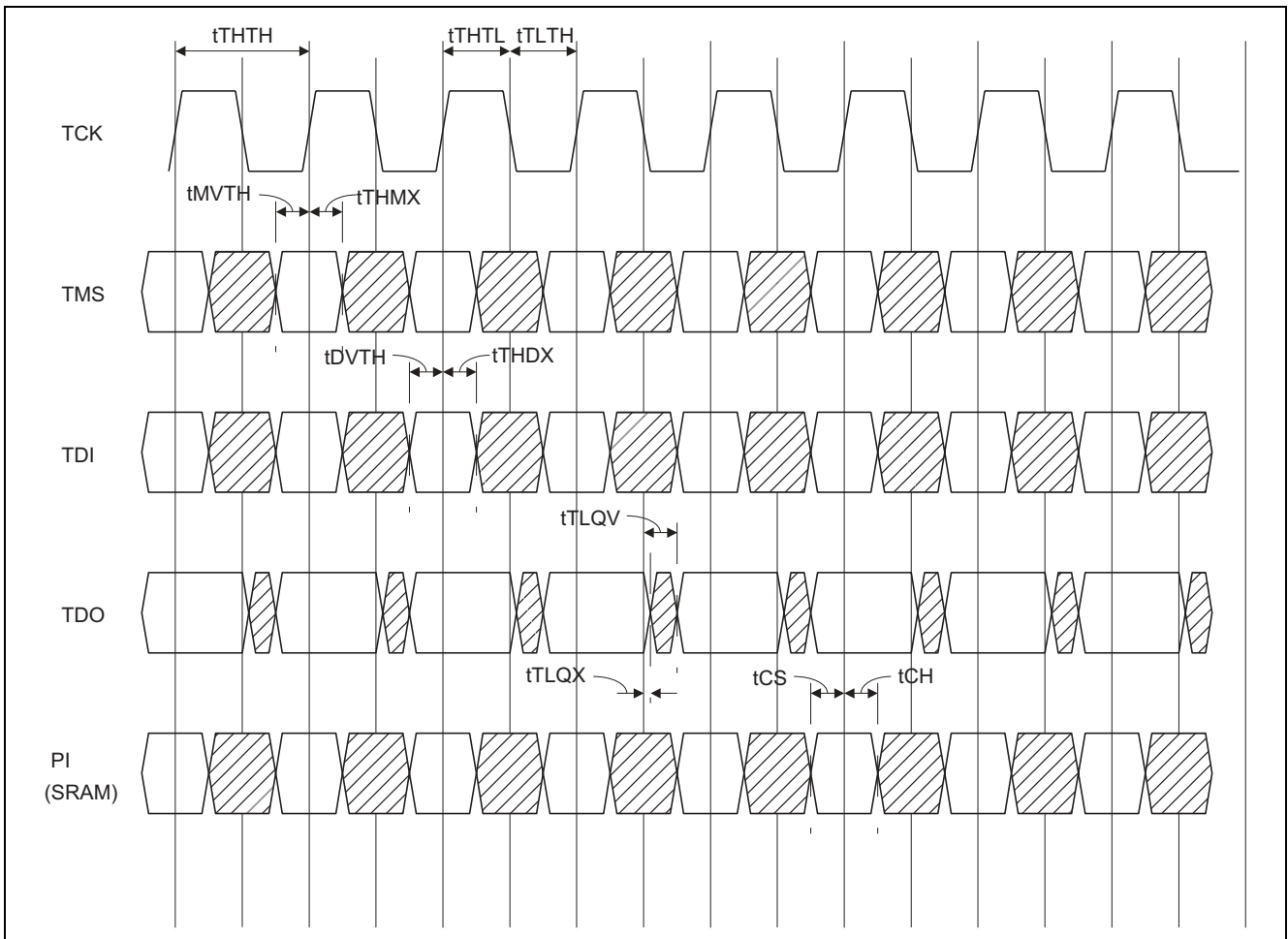

## Test Access Port Registers

Register name	Length	Symbol	Notes
Instruction register	3 bits	IR [2:0]	
Bypass register	1 bits	BP	
ID register	32 bits	ID [31:0]	
Boundary scan register	109 bits	BS [109:1]	

## TAP Controller Instruction Set

IR2	IR1	IR0	Instruction	Description	Notes
0	0	0	EXTEST	The EXTEST instruction allows circuitry external to the component package to be tested. Boundary scan register cells at output balls are used to apply test vectors, while those at input balls capture test results. Typically, the first test vector to be applied using the EXTEST instruction will be shifted into the boundary scan register using the PRELOAD instruction. Thus, during the Update-IR state of EXTEST, the output driver is turned on and the PRELOAD data is driven onto the output balls.	1, 2, 3
0	0	1	IDCODE	The IDCODE instruction causes the ID ROM to be loaded into the ID register when the controller is in capture-DR mode and places the ID register between the TDI and TDO balls in shift-DR mode. The IDCODE instruction is the default instruction loaded in at power up and any time the controller is placed in the Test-Logic-Reset state.	
0	1	0	SAMPLE-Z	If the SAMPLE-Z instruction is loaded in the instruction register, all RAM outputs are forced to an inactive drive state (high-Z), moving the TAP controller into the capture-DR state loads the data in the RAMs input into the boundary scan register, and the boundary scan register is connected between TDI and TDO when the TAP controller is moved to the shift-DR state.	3, 4
0	1	1	RESERVED	The RESERVED instructions are not implemented but are reserved for future use. Do not use these instructions.	
1	0	0	SAMPLE (/PRELOAD)	When the SAMPLE instruction is loaded in the instruction register, moving the TAP controller into the capture-DR state loads the data in the RAMs input and I/O buffers into the boundary scan register. Because the RAM clock(s) are independent from the TAP clock (TCK) it is possible for the TAP to attempt to capture the I/O ring contents while the input buffers are in transition (i.e., in a metastable state). Although allowing the TAP to SAMPLE metastable input will not harm the device, repeatable results cannot be expected. Moving the controller to shift-DR state then places the boundary scan register between the TDI and TDO balls.	3
1	0	1	RESERVED		
1	1	0	RESERVED		
1	1	1	BYPASS	The BYPASS instruction is loaded in the instruction register when the bypass register is placed between TDI and TDO. This occurs when the TAP controller is moved to the shift-DR state. This allows the board level scan path to be shortened to facilitate testing of other devices in the scan path.	

- Notes:
1. Data in output register is not guaranteed if EXTEST instruction is loaded.
  2. After performing EXTEST, power-up conditions are required in order to return part to normal operation.
  3. RAM input signals must be stabilized for long enough to meet the TAPs input data capture setup plus hold time ( $t_{CS}$  plus  $t_{CH}$ ). The RAMs clock inputs need not be paused for any other TAP operation except capturing the I/O ring contents into the boundary scan register.
  4. Clock recovery initialization cycles are required to return from the SAMPLE-Z instruction.

## Boundary Scan Order

Bit #	Ball ID	Signal names		
		x9	x18	x36
1	6R	/C	/C	/C
2	6P	C	C	C
3	6N	SA	SA	SA
4	7P	SA	SA	SA
5	7N	SA	SA	SA
6	7R	SA	SA	SA
7	8R	SA	SA	SA
8	8P	SA	SA	SA
9	9R	SA	SA	SA
10	11P	Q0	Q0	Q0
11	10P	D0	D0	D0
12	10N	NC	NC	D9
13	9P	NC	NC	Q9
14	10M	NC	Q1	Q1
15	11N	NC	D1	D1
16	9M	NC	NC	D10
17	9N	NC	NC	Q10
18	11L	Q1	Q2	Q2
19	11M	D1	D2	D2
20	9L	NC	NC	D11
21	10L	NC	NC	Q11
22	11K	NC	Q3	Q3
23	10K	NC	D3	D3
24	9J	NC	NC	D12
25	9K	NC	NC	Q12
26	10J	Q2	Q4	Q4
27	11J	D2	D4	D4
28	11H	ZQ	ZQ	ZQ
29	10G	NC	NC	D13
30	9G	NC	NC	Q13
31	11F	NC	Q5	Q5
32	11G	NC	D5	D5
33	9F	NC	NC	D14
34	10F	NC	NC	Q14
35	11E	Q3	Q6	Q6
36	10E	D3	D6	D6
37	10D	NC	NC	D15
38	9E	NC	NC	Q15
39	10C	NC	Q7	Q7
40	11D	NC	D7	D7
41	9C	NC	NC	D16
42	9D	NC	NC	Q16
43	11B	Q4	Q8	Q8
44	11C	D4	D8	D8
45	9B	NC	NC	D17
46	10B	NC	NC	Q17
47	11A	CQ	CQ	CQ
48	10A	SA	NC	NC
49	9A	SA	SA	SA

Bit #	Ball ID	Signal names		
		x9	x18	x36
50	8B	SA	SA	SA
51	7C	SA	SA	SA
52	6C	SA	SA	SA
53	8A	/R	/R	/R
54	7A	NC	NC	/BW1
55	7B	/BW	/BW0	/BW0
56	6B	K	K	K
57	6A	/K	/K	/K
58	5B	NC	NC	/BW3
59	5A	NC	/BW1	/BW2
60	4A	/W	/W	/W
61	5C	SA	SA	SA
62	4B	SA	SA	SA
63	3A	SA	SA	NC
64	2A	V <sub>SS</sub>	V <sub>SS</sub>	V <sub>SS</sub>
65	1A	/CQ	/CQ	/CQ
66	2B	NC	Q9	Q18
67	3B	NC	D9	D18
68	1C	NC	NC	D27
69	1B	NC	NC	Q27
70	3D	NC	Q10	Q19
71	3C	NC	D10	D19
72	1D	NC	NC	D28
73	2C	NC	NC	Q28
74	3E	Q5	Q11	Q20
75	2D	D5	D11	D20
76	2E	NC	NC	D29
77	1E	NC	NC	Q29
78	2F	NC	Q12	Q21
79	3F	NC	D12	D21
80	1G	NC	NC	D30
81	1F	NC	NC	Q30
82	3G	Q6	Q13	Q22
83	2G	D6	D13	D22
84	1H	/DOFF	/DOFF	/DOFF
85	1J	NC	NC	D31
86	2J	NC	NC	Q31
87	3K	NC	Q14	Q23
88	3J	NC	D14	D23
89	2K	NC	NC	D32
90	1K	NC	NC	Q32
91	2L	Q7	Q15	Q24
92	3L	D7	D15	D24
93	1M	NC	NC	D33
94	1L	NC	NC	Q33
95	3N	NC	Q16	Q25
96	3M	NC	D16	D25
97	1N	NC	NC	D34
98	2M	NC	NC	Q34

Bit #	Ball ID	Signal names		
		x9	x18	x36
99	3P	Q8	Q17	Q26
100	2N	D8	D17	D26
101	2P	NC	NC	D35
102	1P	NC	NC	Q35
103	3R	SA	SA	SA
104	4R	SA	SA	SA

Bit #	Ball ID	Signal names		
		x9	x18	x36
105	4P	SA	SA	SA
106	5P	SA	SA	SA
107	5N	SA	SA	SA
108	5R	SA	SA	SA
109	—	INTERNAL	INTERNAL	INTERNAL

Notes: In boundary scan mode,

1. Clock balls (K, /K, C, /C) are referenced to each other and must be at opposite logic levels for reliable operation.
2. CQ and /CQ data are synchronized to the respective C and /C (except EXTEST, SAMPLE-Z).
3. If C and /C tied high, CQ is generated with respect to K and /CQ is generated with respect to /K (except EXTEST, SAMPLE-Z).
4. ZQ must be driven to  $V_{DDQ}$  supply to ensure consistent results.

### ID Register

Part	Revision number (31:29)	Type number (28:12)	Vendor JEDEC code (11:1)	Start bit (0)
—	—	0 0MMM 0WW0 10Q0 B0S0	—	—
R1Q2A3636	000	0 0010 0110 1010 0010	0100 0100 011	1
R1Q2A3618	000	0 0010 0100 1010 0010	0100 0100 011	1
R1Q2A3609	000	0 0010 0000 1010 0010	0100 0100 011	1

Notes: 1. Type number

MMM :Density	011:72Mb,	010:36Mb,	001:18Mb
WW :Organization	11: x 36,	10: x 18,	00: x 9,      01: x 8
Q :QDR/DDR	1: QDR,	0: DDR	
B :Burst lengths	1: 4-word burst,	0: 2-word burst	
S :I/O	1: Separate I/O,	0: Common I/O	

### TAP Controller State Diagram

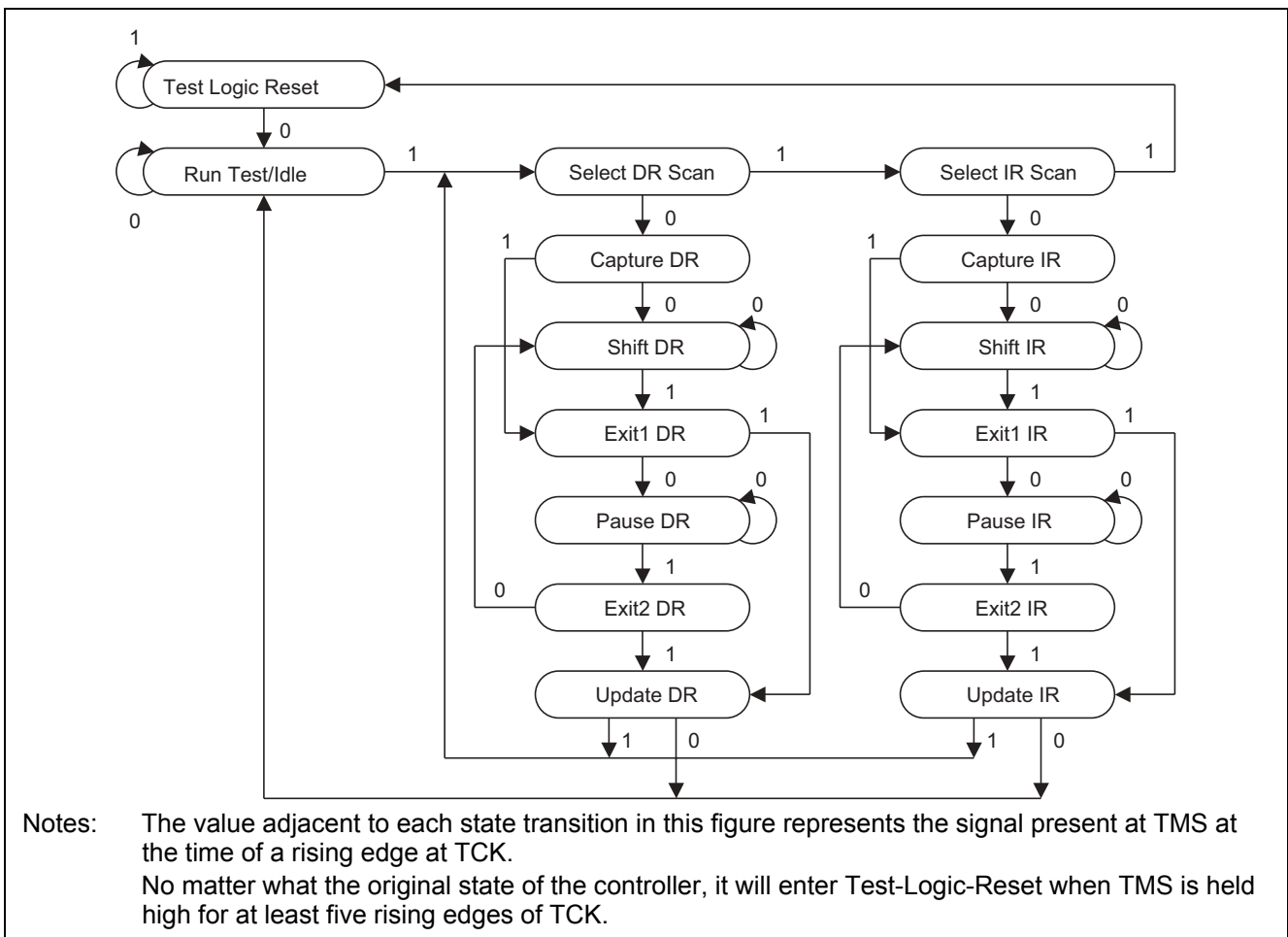

### Package Dimensions

R1Q2A3636/R1Q2A3618/ R1Q2A3609 (PLBG0165FB-A)

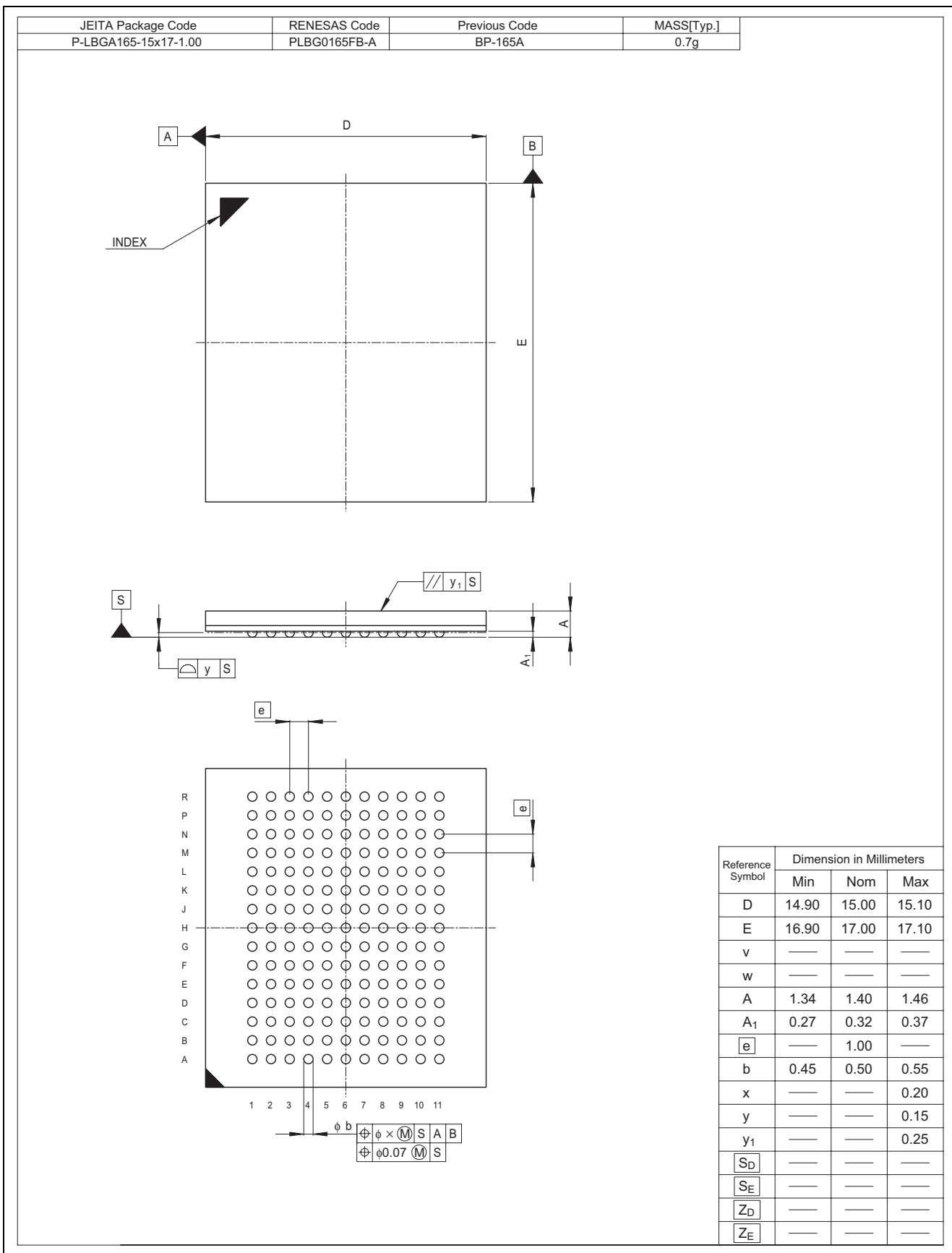

## Revision History

R1Q2A3636/R1Q2A3618/R1Q2A3609  
Data Sheet

Rev.	Date	Contents of Modification	
		Page	Description
0.01	Sep. 25, 2006	—	Initial issue
0.02	Feb. 22, 2007	23	Package Dimensions PLBG0165FC-A to PLBG0165FB-A
0.03	Jul. 31, 2007	6	General Description: Adding description for clock stop to reset DLL.
		11	DC Characteristics: Fixing data sheet errata for standby supply current (NOP) since the previous value were same as 1st generation devices. $I_{SB1}$ (-40R/-50R/-60R) (max): 350/340/330 mA
		12	Capacitance: Reducing capacitance value to describe actual performance. $C_{IN}$ (typ/max): 2/3 pF $C_{CLK}$ (typ/max): 2/3 pF $C_{I/O}$ (typ/max): 3/4.5 pF
		14	AC Characteristics: Average clock cycle time is enlarged. $t_{KHKH}$ (-60R) (max): 8.00 ns Clock to data clock is tightened to reduce switching noise between outputs switching while inputs are being sampled. $t_{KHCH}$ (-40R/-50R/-60R) (max): 1.10/1.60/2.10 ns Adding of remarks 6 for $t_{CHQV}$ , $t_{CHCQV}$ , $t_{CHQX}$ , and $t_{CHCQX}$ on R1Q2A3636ABG (-40R, -50R) devices.



Notes:

1. This document is provided for reference purposes only so that Renesas customers may select the appropriate Renesas products for their use. Renesas neither makes warranties or representations with respect to the accuracy or completeness of the information contained in this document nor grants any license to any intellectual property rights or any other rights of Renesas or any third party with respect to the information in this document.
2. Renesas shall have no liability for damages or infringement of any intellectual property or other rights arising out of the use of any information in this document, including, but not limited to, product data, diagrams, charts, programs, algorithms, and application circuit examples.
3. You should not use the products or the technology described in this document for the purpose of military applications such as the development of weapons of mass destruction or for the purpose of any other military use. When exporting the products or technology described herein, you should follow the applicable export control laws and regulations, and procedures required by such laws and regulations.
4. All information included in this document such as product data, diagrams, charts, programs, algorithms, and application circuit examples, is current as of the date this document is issued. Such information, however, is subject to change without any prior notice. Before purchasing or using any Renesas products listed in this document, please confirm the latest product information with a Renesas sales office. Also, please pay regular and careful attention to additional and different information to be disclosed by Renesas such as that disclosed through our website. (<http://www.renesas.com>)
5. Renesas has used reasonable care in compiling the information included in this document, but Renesas assumes no liability whatsoever for any damages incurred as a result of errors or omissions in the information included in this document.
6. When using or otherwise relying on the information in this document, you should evaluate the information in light of the total system before deciding about the applicability of such information to the intended application. Renesas makes no representations, warranties or guarantees regarding the suitability of its products for any particular application and specifically disclaims any liability arising out of the application and use of the information in this document or Renesas products.
7. With the exception of products specified by Renesas as suitable for automobile applications, Renesas products are not designed, manufactured or tested for applications or otherwise in systems the failure or malfunction of which may cause a direct threat to human life or create a risk of human injury or which require especially high quality and reliability such as safety systems, or equipment or systems for transportation and traffic, healthcare, combustion control, aerospace and aeronautics, nuclear power, or undersea communication transmission. If you are considering the use of our products for such purposes, please contact a Renesas sales office beforehand. Renesas shall have no liability for damages arising out of the uses set forth above.
8. Notwithstanding the preceding paragraph, you should not use Renesas products for the purposes listed below:
  - (1) artificial life support devices or systems
  - (2) surgical implantations
  - (3) healthcare intervention (e.g., excision, administration of medication, etc.)
  - (4) any other purposes that pose a direct threat to human lifeRenesas shall have no liability for damages arising out of the uses set forth in the above and purchasers who elect to use Renesas products in any of the foregoing applications shall indemnify and hold harmless Renesas Technology Corp., its affiliated companies and their officers, directors, and employees against any and all damages arising out of such applications.
9. You should use the products described herein within the range specified by Renesas, especially with respect to the maximum rating, operating supply voltage range, movement power voltage range, heat radiation characteristics, installation and other product characteristics. Renesas shall have no liability for malfunctions or damages arising out of the use of Renesas products beyond such specified ranges.
10. Although Renesas endeavors to improve the quality and reliability of its products, IC products have specific characteristics such as the occurrence of failure at a certain rate and malfunctions under certain use conditions. Please be sure to implement safety measures to guard against the possibility of physical injury, and injury or damage caused by fire in the event of the failure of a Renesas product, such as safety design for hardware and software including but not limited to redundancy, fire control and malfunction prevention, appropriate treatment for aging degradation or any other applicable measures. Among others, since the evaluation of microcomputer software alone is very difficult, please evaluate the safety of the final products or system manufactured by you.
11. In case Renesas products listed in this document are detached from the products to which the Renesas products are attached or affixed, the risk of accident such as swallowing by infants and small children is very high. You should implement safety measures so that Renesas products may not be easily detached from your products. Renesas shall have no liability for damages arising out of such detachment.
12. This document may not be reproduced or duplicated, in any form, in whole or in part, without prior written approval from Renesas.
13. Please contact a Renesas sales office if you have any questions regarding the information contained in this document, Renesas semiconductor products, or if you have any other inquiries.



**RENESAS SALES OFFICES**

<http://www.renesas.com>

Refer to "<http://www.renesas.com/en/network>" for the latest and detailed information.

**Renesas Technology America, Inc.**  
450 Holger Way, San Jose, CA 95134-1368, U.S.A  
Tel: <1> (408) 382-7500, Fax: <1> (408) 382-7501

**Renesas Technology Europe Limited**  
Dukes Meadow, Millboard Road, Bourne End, Buckinghamshire, SL8 5FH, U.K.  
Tel: <44> (1628) 585-100, Fax: <44> (1628) 585-900

**Renesas Technology (Shanghai) Co., Ltd.**  
Unit 204, 205, AZIACenter, No.1233 Lujiazui Ring Rd, Pudong District, Shanghai, China 200120  
Tel: <86> (21) 5877-1818, Fax: <86> (21) 6887-7898

**Renesas Technology Hong Kong Ltd.**  
7th Floor, North Tower, World Finance Centre, Harbour City, 1 Canton Road, Tsimshatsui, Kowloon, Hong Kong  
Tel: <852> 2265-6688, Fax: <852> 2730-6071

**Renesas Technology Taiwan Co., Ltd.**  
10th Floor, No.99, Fushing North Road, Taipei, Taiwan  
Tel: <886> (2) 2715-2888, Fax: <886> (2) 2713-2999

**Renesas Technology Singapore Pte. Ltd.**  
1 Harbour Front Avenue, #06-10, Keppel Bay Tower, Singapore 098632  
Tel: <65> 6213-0200, Fax: <65> 6278-8001

**Renesas Technology Korea Co., Ltd.**  
Kukje Center Bldg. 18th Fl., 191, 2-ka, Hangang-ro, Yongsan-ku, Seoul 140-702, Korea  
Tel: <82> (2) 796-3115, Fax: <82> (2) 796-2145

**Renesas Technology Malaysia Sdn. Bhd**  
Unit 906, Block B, Menara Amcorp, Amcorp Trade Centre, No.18, Jalan Persiaran Barat, 46050 Petaling Jaya, Selangor Darul Ehsan, Malaysia  
Tel: <603> 7955-9390, Fax: <603> 7955-9510