

April 2006

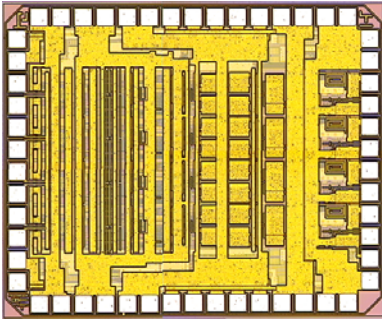

Features

- 4-channel integrated transimpedance and limiting amplifier operates up to 4.25 Gb/s
- 8 μA_{PP} receiver sensitivity for 10^{-12} BER
- Single +3.3V supply dissipating 105 mW per channel
- Individual channel signal detect compares input signal strength (OMA) with adjustable threshold
- Global signal detect compares quiescent photocurrent with adjustable threshold
- Squelch automatically disables output when input signal strength falls below programmable threshold
- Serial digital interface for controlling channel enable and signal detect features
- Reconfigurable I/O provides access to serial digital interface and dedicated channel signal detect outputs
- 250-micron channel pitch matches optical ribbon fiber and photodiode arrays

Applications

- 10GbE LX-4 optical modules
- 4-lane 4GFC, OC-48 VSR, Infiniband™ parallel optical modules
- Proprietary parallel optical modules and CWDM
- Proprietary 4-lane intra-system parallel optics

Description

The growing use of the Internet has created increasingly higher demand for multi-Gb/s I/O performance. The demand for 40+ Gb/s WAN bandwidth fuels the growth of short-reach 10 Gb/s infrastructures within high-end telco and datacom routers, switches, servers and other proprietary chassis-to-chassis links. The Zarlink PX5524 4 Gb/s TIA/LA Receiver is a four-channel TIA/LA optical receiver designed for various 4x4 Gb/s parallel optics and CWDM PMD applications. It consists of a DC-coupled transimpedance amplifier and an AC-coupled differential limiting amplifier.

The transimpedance amplifier achieves a nominal 3 GHz bandwidth over a wide range of photodiode input capacitance. Excellent channel-to-channel isolation ensures data integrity at the receiver sensitivity limits. A global signal detect circuit provides the photodiode reverse bias voltage supply and senses average photocurrent supplied to the photodiode array.

The transimpedance amplifier is AC-coupled internally to a high-gain, high-bandwidth differential limiting amplifier. The limiting amplifier provides a differential back-terminated CML output that can be used to drive 4 Gb/s per channel transceivers or other CML compatible clock and data recovery circuits. The limiting amplifier features an adjustable signal detect circuit that senses optical modulation amplitude (OMA) to provide a received signal indication for each channel.

Figure 1: Representative electrical data pattern from the PX5524 IC output. Input OMA of -14.5 dBm received through a commercially-available photodiode at 3.0 Gb/s with a PRBS23 pattern.

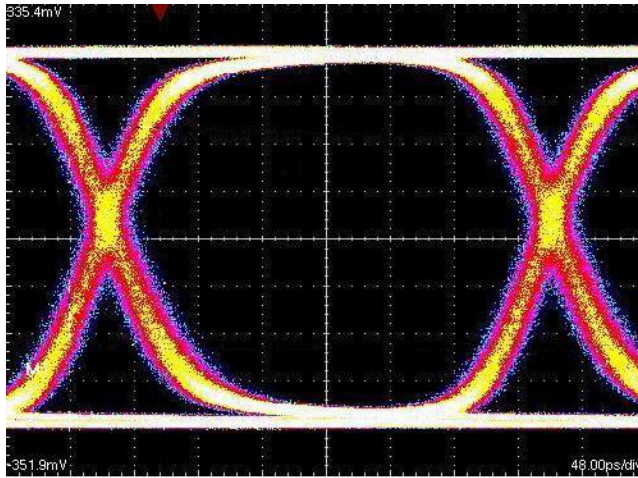
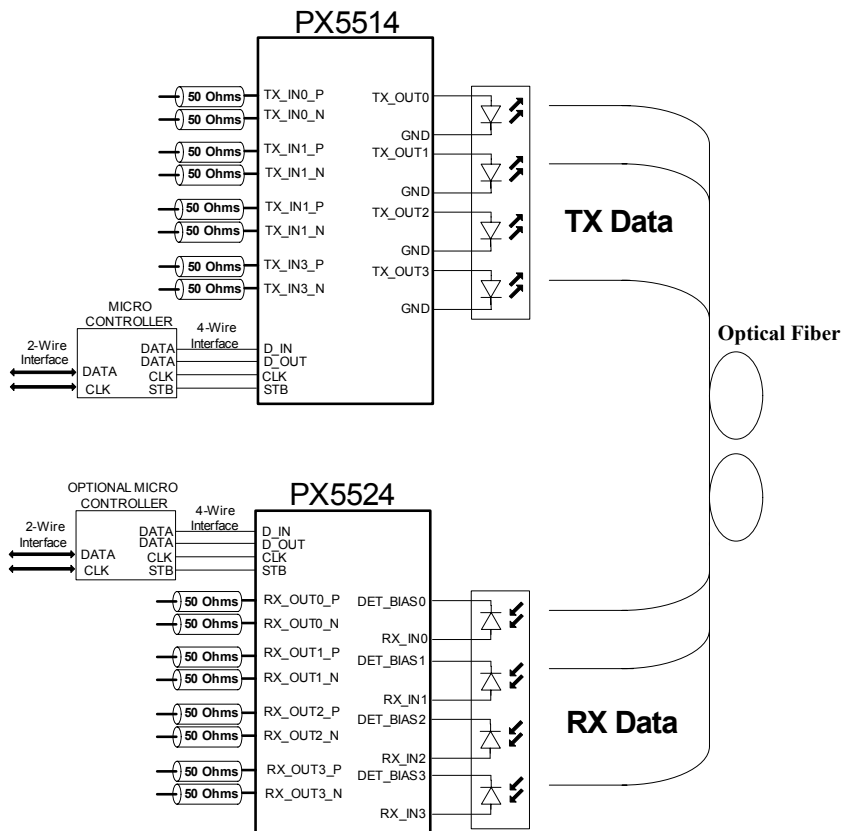

Figure 2: Application block diagram utilizing the PX5514 VCSEL driver and the PX5524 optical receiver





**For more information about all Zarlink products
visit our Web Site at
www.zarlink.com**

Information relating to products and services furnished herein by Zarlink Semiconductor Inc. or its subsidiaries (collectively "Zarlink") is believed to be reliable. However, Zarlink assumes no liability for errors that may appear in this publication, or for liability otherwise arising from the application or use of any such information, product or service or for any infringement of patents or other intellectual property rights owned by third parties which may result from such application or use. Neither the supply of such information or purchase of product or service conveys any license, either express or implied, under patents or other intellectual property rights owned by Zarlink or licensed from third parties by Zarlink, whatsoever. Purchasers of products are also hereby notified that the use of product in certain ways or in combination with Zarlink, or non-Zarlink furnished goods or services may infringe patents or other intellectual property rights owned by Zarlink.

This publication is issued to provide information only and (unless agreed by Zarlink in writing) may not be used, applied or reproduced for any purpose nor form part of any order or contract nor to be regarded as a representation relating to the products or services concerned. The products, their specifications, services and other information appearing in this publication are subject to change by Zarlink without notice. No warranty or guarantee express or implied is made regarding the capability, performance or suitability of any product or service. Information concerning possible methods of use is provided as a guide only and does not constitute any guarantee that such methods of use will be satisfactory in a specific piece of equipment. It is the user's responsibility to fully determine the performance and suitability of any equipment using such information and to ensure that any publication or data used is up to date and has not been superseded. Manufacturing does not necessarily include testing of all functions or parameters. These products are not suitable for use in any medical products whose failure to perform may result in significant injury or death to the user. All products and materials are sold and services provided subject to Zarlink's conditions of sale which are available on request.

Purchase of Zarlink's I²C components conveys a licence under the Philips I²C Patent rights to use these components in and I²C System, provided that the system conforms to the I²C Standard Specification as defined by Philips.

Zarlink, ZL and the Zarlink Semiconductor logo are trademarks of Zarlink Semiconductor Inc.

Copyright Zarlink Semiconductor Inc. All Rights Reserved.

TECHNICAL DOCUMENTATION - NOT FOR RESALE
