



REVISION NUMBER : REV 1	PAGES : 1 of 13
DATE : 2-23-04	
<p>PI627MC-A4 / PI628MC-A4 / PI629MC-A4 Contact Image Sensor Modules</p> <p>Engineering Data Sheet</p> <p>A Family of 600DPI CIS Modules, each with a specific LED light source</p>	

Key Features

- LED Light source, lens, and sensor are integrated into a single module
- Ultra-high-speed
- Four parallel analog video outputs, clocked as high as 5.5MHz
- 270 μ sec/line scanning speed @ 5.0MHz clock rate for the red light source
- 23.62 dots/mm resolution, 216 mm scanning length
- Wide dynamic range
- Standard A4 size \cong 14.5mm x 19.5 mm x 232 mm
- Low power
- Light weight

General Description

The PI627MC-A4, PI628MC-A4 and PI629MC-A4 are a family of Contact Image Sensor (CIS) modules, using MOS image sensor technology for high-speed performance and high sensitivity. They contain a complete optical imaging system that includes the light source and focusing elements.

The modules' contact image sensor is divided into four sections, each with its own video output and identical processing circuits allowing for high scanning speeds. Each module comes with its own particular LED light source, which have different maximum light power outputs. Since the light power limits the exposure, which is proportional to the product of scanning speed and light power, each module will have a different maximum scanning speed and signal output voltage.

The modules can be used for scanning A4 size (216 mm) documents with 23.62 dots per millimeter resolution. Applications include document scanning, mark readers, gaming and office automation equipment.

Functional Description

Each of the 3 modules consists of 27 PI3039 image sensors cascaded together. Each sensor consists of 192 photo-sensing elements (pixels), resulting in a module 5184 pixels long.

These image sensors have associated multiplex switches that are sequentially accessed with its digital shift register. In addition, each has a chip-select switch that functions to activate its preceding sensor on the cascaded sequence, after its predecessor chip has completed its scan. The start pulse initiates the shift register of the first chip in all four sections. The first chip then sequentially clocks out the integrated image charge from each pixel. These charges are passed through the sensors' multiplexing switch and then out onto the video line, where they are converted to a voltage. When the sensor completes its scan, the chip-select switch on the following chip is switched on to continue the line scan until it completes its scan in one section. A new scan is initiated when a start pulse is again entered into the first chip of each section.

The 27 sensors are cascaded together and bonded onto a PCB. The cascaded sensors are then divided into 4 subsections, each subsection having its own output. The first 3 subsections contain 7 sensors and the 4th contains 6 sensors. Each output is then connected to its own video line. The four video lines form a video line capacitance, which are buffered by video amplifiers, to act as output drivers. The charge from each output is integrated onto the video line capacitance and readout. Each pixel is then reset and ready to integrate again.

Mounted in the module is a one-to-one graded indexed micro lens array that focuses the scanned documents to be imaged onto its sensing plane.

Illumination is by means of an integrated LED light source. The particular Led for each module is listed in Table 1

Module	LED Type
PI627MC-A4	660nm Red LED Bar
PI628MC-A4	High power Yellow-Green LED Bar
PI629MC-A4	Low power Yellow-Green LED Bar

Table 1. Module vs LED Light Source

All components are housed in a small plastic housing which has a glass cover that acts as the focal point for the object being scanned and protects the imaging array, micro lens assembly, and LED light source from dust.

Figures 1 and 2 on page 4 show a block diagram and a cross section of a module.

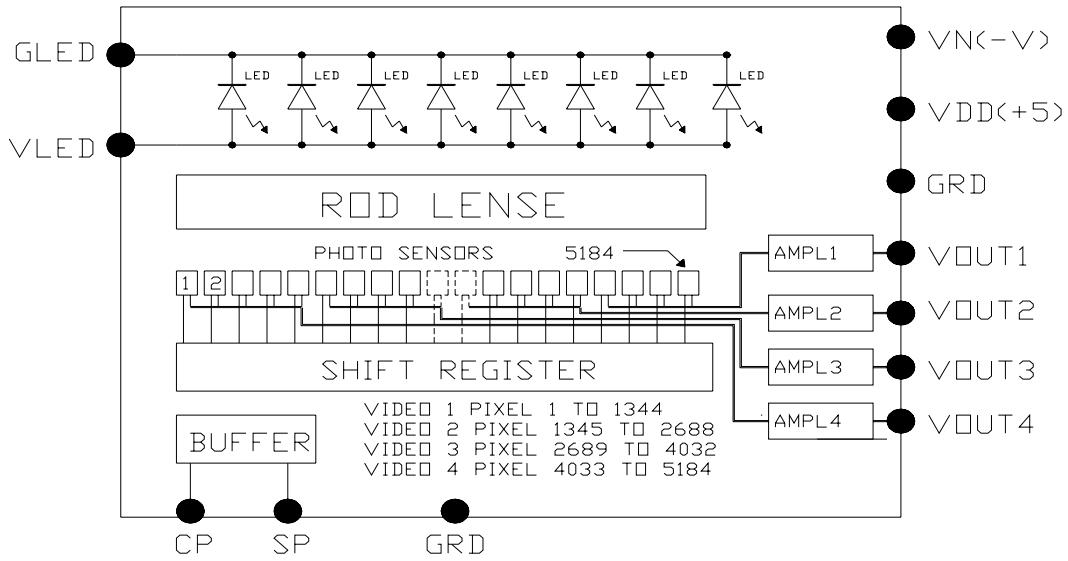

Figure 1. Module Block Diagram

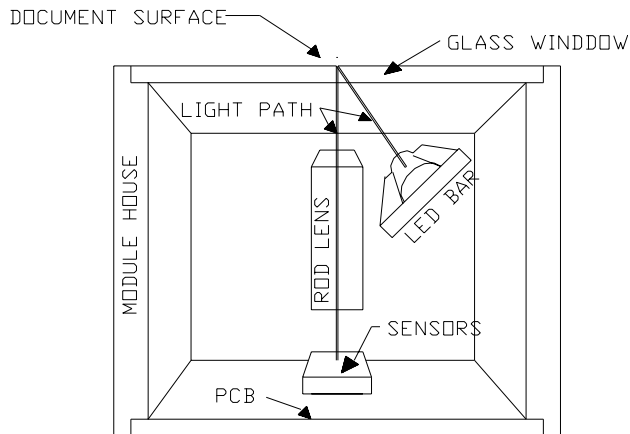

Figure 2. Module Cross Section

Connector Pin-Out

Inputs and outputs to the module are via a 12-pin connector, part number JAE IL-Z-12P-S125L3-E, located on one end of the module.

Table 2 lists the connector pin-out with their symbols and descriptions.

Connector Pin Number	Symbol	Description
1	VOUT1	Analog video output 1
2	VOUT2	Analog video output 2
3	GND	Ground
4	VOUT3	Analog video output 3
5	VOUT4	Analog video output 4
6	Vdd	Power supply
7	SP(START)	Shift register start pulse
8	GND	Ground
9	CP(CLOCK)	Clock pulse
10	Vn	Negative power supply
11	GLLED	Ground for the light source
12	VLED	Power supply for the light source

Table 2. Pin-out configuration

Absolute Maximum Rating

Table 3 shows the absolute maximum ratings for the parameters common to all three modules. As each module has its own particular LED source, table 4 shows the absolute maximum ratings particular to each of the 3 LED light sources. These are the absolute maximum ratings and continuous operation is not recommended.

Parameter	Symbol	Max Rating	Units
Power Supply	Vdd	7	V
	Idd	100	mA
	Vn	-15	V
	In	20	mA
Input clock pulse (high level)	Vih	Vdd - 0.5V	V
Input clock pulse (low level)	Vil	-0.5	V

Table 3. Absolute Maximum Ratings Common to all 3 Modules

Parameter	Max Rating			Units
	PI627MC-A4 / 660nm Red LED	PI628MC-A4 / High Power Yellow-Green LED	PI629MC-A4 / Low Power Yellow-Green LED	
VLED	5.5	5.5	5.5	V
ILED	0.7	1.0	1.0	A

Table 4. LED Absolute Maximum Ratings

Environmental Specifications

Table 5 lists the environmental conditions for the modules.

Parameter	Max Rating	Units
Operating temperature	0 to 50	°C
Operating humidity	10 to 90	%
Storage temperature	-20 to+75	°C
Storage humidity	10 to 90	%

Table 5. Operating and Storage Environment

Electro-Optical Characteristics at 25°C

Table 6 lists the electro-optical characteristics common to all three modules. Tables 7, 8 and 9 show the characteristics particular to each of the 3 LED light sources.

Parameter	Value	Units
Total Number of Pixels in each module	5184	Elements
Number of pixels in Sections 1, 2 & 3	1344	Elements
Number of pixels in Section 4	1152	Elements
Pixel-to-pixel spacing	42.3	µm

Table 6. Electro-Optical Characteristics Common to all 3 Modules

Module: PI627MC-A4

Light source: 660nm RED LED

Parameter	Symbol	Value	Units	Note
Line scanning rate ⁽¹⁾	Tint	270	µsec	@ 5.0MHz clock frequency
Clock frequency ⁽²⁾	Fclk	5.0	MHz	
Bright output voltage ⁽³⁾⁽⁷⁾	Video Output	1.0	Volt	
Bright output nonuniformity ⁽⁴⁾	Up	< +/-30	%	
Adjacent photo-response non-uniformity ⁽⁵⁾	Upn	<25	%	
Dark nonuniformity ⁽⁶⁾	Ud	< 100	mV	
Dark output voltage ⁽⁷⁾	Dark Level (DL)	< 450	mV	
Modulation transfer function ⁽⁸⁾	MTF	> 40	%	

Table 7. PI627MC-A4 / 660nm Red LED Electro-Optical Characteristics

Module: PI628MC-A4

Light source: High Power Yellow-Green LED

Parameter	Symbol	Value	Units	Note
Line scanning rate ⁽¹⁾	Tint	270	µsec	@ 5.0MHz clock frequency
Clock frequency ⁽²⁾	Fclk	5.0	MHz	
Bright output voltage ⁽³⁾⁽⁷⁾	Video Output	0.5	Volt	
Bright output nonuniformity ⁽⁴⁾	Up	< +/-30	%	
Adjacent photo-response non-uniformity ⁽⁵⁾	Upn	<25	%	
Dark nonuniformity ⁽⁶⁾	Ud	< 100	mV	
Dark output voltage ⁽⁷⁾	Dark Level (DL)	< 450	mV	
Modulation transfer function ⁽⁸⁾	MTF	> 40	%	

Table 8. PI628MC-A4 / High Power Yellow-Green LED Electro-Optical Characteristics

Module: PI629MC-A4

Light source: Low Power Yellow-Green LED

Parameter	Symbol	Value	Units	Notes
Line scanning rate ⁽¹⁾	Tint	450	μsec	@ 3.0MHz clock frequency
Clock frequency ⁽²⁾	Fclk	3.0	MHz	
Bright output voltage ⁽³⁾⁽⁷⁾	Video Output	0.5	Volt	
Bright output nonuniformity ⁽⁴⁾	Up	< +/-30	%	
Adjacent photo-response non-uniformity ⁽⁵⁾	Upn	<25	%	
Dark nonuniformity ⁽⁶⁾	Ud	< 100	mV	
Dark output voltage ⁽⁷⁾	Dark Level (DL)	< 350	mV	
Modulation transfer function ⁽⁸⁾	MTF	> 40	%	

Table 9. PI629MC-A4 / Low Power Yellow-Green LED Electro-Optical Characteristics

Notes:

1. Tint is the line-scanning rate or integration time and is determined by the interval between two start pulses, SP. The integration time listed for each module is the minimum integration time required to give 0.5 volts output at each modules maximum clock frequency.
2. Fclk is the main clock frequency, also equals the pixel rate.
3. Video output level is dependent on the Integration time and LED light power.
4. $Up = [Vp(max) - Vpavg] / Vpavg \times 100\%$ or $[Vpavg - Vp(min)] / Vpavg \times 100\%$, whichever is greater. Where $Vp(max)$ = maximum pixel level, $Vp(min)$ = minimum pixel level, and $Vpavg$ = average of all pixels.
5. Adjacent Photo-Response Non-Uniformity (Upn).
 $Upn = \text{Max} ((Vpn - Vpn+1) / \text{Min} (Vpn, Vpn+1)) \times 100\%$, where Vpn is the pixel output voltage of pixel n in the light.
6. $Ud = Vdmax - Vdmin$, where $Vdmin$ is the minimum output voltage with LED off and $Vdmax$ is maximum output voltage with LED on.
7. See paragraph under Reset Level and Video Sampling Time on page 10 for explanation.
8. See the paragraph under Depth of Focus on page 11. A graph of the typical MTF vs Depth of Focus is shown.

Recommended Operating Conditions at 25 °C

Table 10 lists the recommended operating conditions common to all three modules. Table 11 lists the recommended operating conditions particular to each of the three LED light sources.

Parameter	Symbol	Min	Typical	Max	Units
Power Supply	Vdd (positive)	4.5	5.0	5.5	V
	Vn (negative)	-10	-5	-4.0	V
	Idd (positive)	60	66	75	mA
	In (negative)	19	20	21	mA
Input voltage (high level)	Vih	Vdd - 1.0	Vdd -0.5	Vdd	V
Input voltage (low level)	Vil	0		0.6	V
Clock frequency ⁽¹⁾	Fclk	0.518		5.5	MHz
Clock pulse high duty cycle	Duty	25	50	75	%
Clock pulse high duration	Pwck	46			ns
Integration time ⁽¹⁾	Tint	82	150		µs
Operating temperature	Top		25	50	°C

Table 10. Recommended Operating Conditions at 25 °C, common to all 3 modules

LED Light Source	Parameter	Min	Typical	Max	Units
660nm Red LED	VLED		5.0	5.5	Volts
	ILED		480	550	mA
High Power Yellow-Green LED	VLED		5.0	5.5	Volts
	ILED		TBD	TBD	mA
Low Power Yellow-Green LED	VLED		5.0	5.5	Volts
	ILED		TBD	TBD	mA

Table 11. Recommended Operating Conditions at 25 °C, for each LED

Note

1. The maximum clock speed is limited by the modules light source power, due to the low light power associated with LED's.
The minimum clock speed is determined by the longest tolerable integration time. Because of the leakage current build up, the integration time is recommended to be no greater than 10 ms.

Reset Level and Video Sampling Time

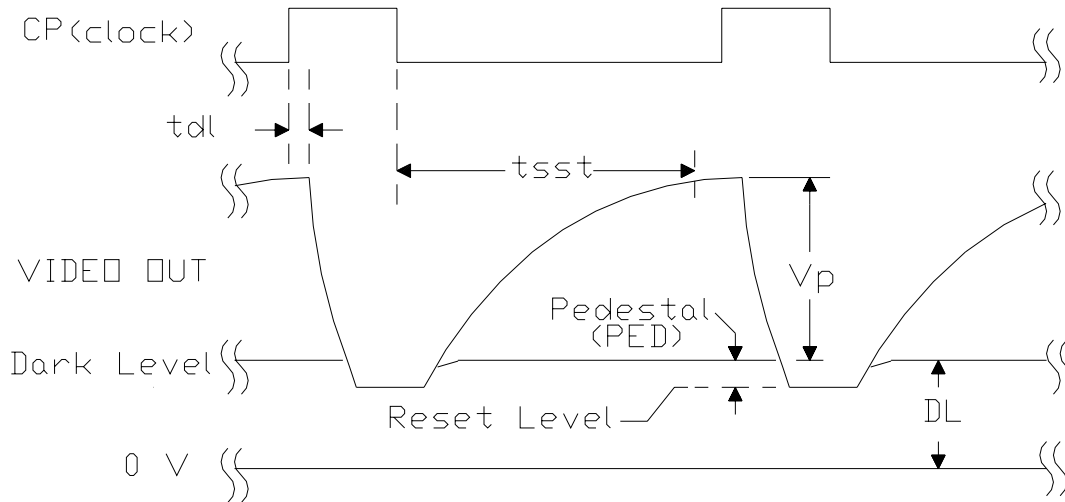

Figure 3. Reset Level and Sample Time

Figure 3 shows the video signal waveform and details a single pixel. The signal output waveform is shown referenced to the input clock waveform. Also shown is the terminology used to define the dark and bright output levels and the recommended pixels sampling times.

The dark level is defined by using the module imaging on a black target or with the light source turned off. The dark level is then measured from ground or 0 volts. The reset level is a reference level of the reset switch, which is not necessarily at ground. The reason for this is that after the reset operation, the video signal is passed through an amplifier, which may have some offsets. The difference between the dark level and reset level is called the pedestal, PED. Hence, the reset level will sit below the dark level.

The video pixels, demonstrated in this graph, are ideal waveforms from a CIS module using a phototransistor imaging structure. The video output at high speeds, such as 5.0 MHz, does not instantly rise to its final value, although, if it is given enough time it would eventually approach its steady state value (in order of milliseconds). However, at high speeds it is impractical to wait until a final stable value is reached. The suggested sampling point is therefore a few nanoseconds prior to the signal falling edge.

Depth of Focus

Figure 4 shows the typical MTF versus Distance, which can be used to define the working depth of focus. Two curves indicate the spread among the modules. Note that the MTF is greater than 40% out to a distance greater than 0.3 mm from the glass surface. Since this module is a 600DPI module, a pixel density of 600 pixels per inch, the MTF was measured with a 300 DPI or a 150 line-pair per inch optical bar pattern. The test was conducted with pixel rate set to 5.0MHz.

The effective algorithm used in the measurements is as described by the following equation:

$$MTF = \frac{[Vp(n)+Vp(n+1)]/2 - [Vp(n+2)+Vp(n+3)]/2}{[Vp(n)+Vp(n+1)]/2 + [Vp(n+2)+Vp(n+3)]/2}$$

Where n is 1, 2,5184th, Vp(n) is the signal amplitude of the nth pixel.

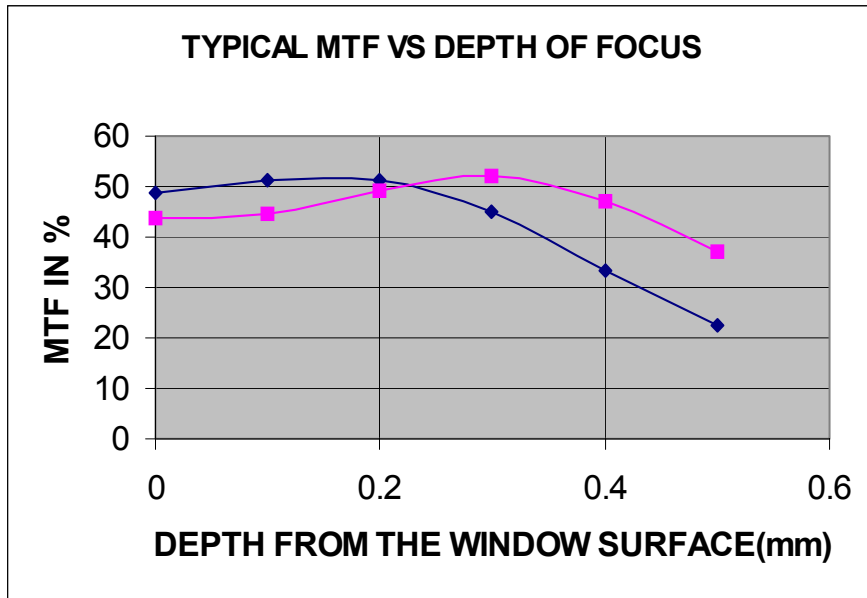

Figure 4. Typical MTF versus Distance

Timing Characteristics at 25°C

The Timing Characteristics at 25°C for the I/O clocks are shown in Figure 5 and their definitions detailed in Table 12. Only one video output is shown because all four video sections have identical electrical characteristics. Since there is 7 die in sections 1, 2 and 3 and 6 die in section 4, the output waveform for section 4 (Vout 4) is shorter by 192 pixels.

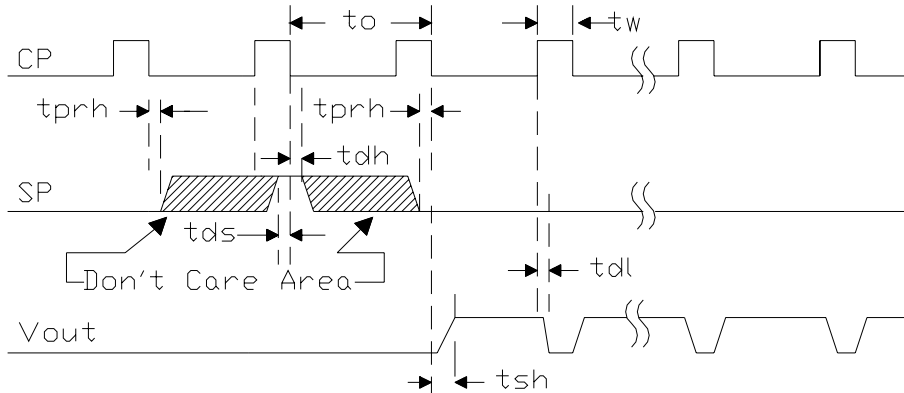

Figure 5. Module Timing Diagram

Item	Symbol	Min	Typical	Max	Units
Clock cycle time	t_o	0.182		1.93	μ s
Clock pulse width	t_w	46		1448	ns
Clock duty cycle		25		75	%
Prohibit crossing time of the Start Pulse ⁽¹⁾	t_{prh}	50			ns
Data setup time	t_{ds}	50			ns
Data hold time	t_{dh}	50			ns
Signal delay time	t_{dl}	50			ns
Signal settling time	t_{sh}	100			ns

Table 12. Timing Definitions

Note

1. "Prohibit crossing of the start pulse", t_{prh} , is to indicate that the start pulse should not be active high between two consecutive low going clock pulses. All falling clock edges under an active high start pulse loads the internal shift register, therefore the start pulse must be active over only one falling clock edge. A high start pulse crossing over any rising clock edges are ignored by the shift register. One simple way to ensure that the start pulse will not be actively high for any two consecutive falling clock edges is to generate the start pulse on a rising clock edge and terminate it on the following rising clock edge.

Mechanical Structure of the Module

Figure 6 is an overview of the module housing showing the connector location, the module's approximate overall dimensions and its general layout. It is not intended for use as a design reference. A detailed drawing for the any of the PI627MC-A4 / PI628MC-A4 / PI629MC-A4 Module Housings is available upon request.

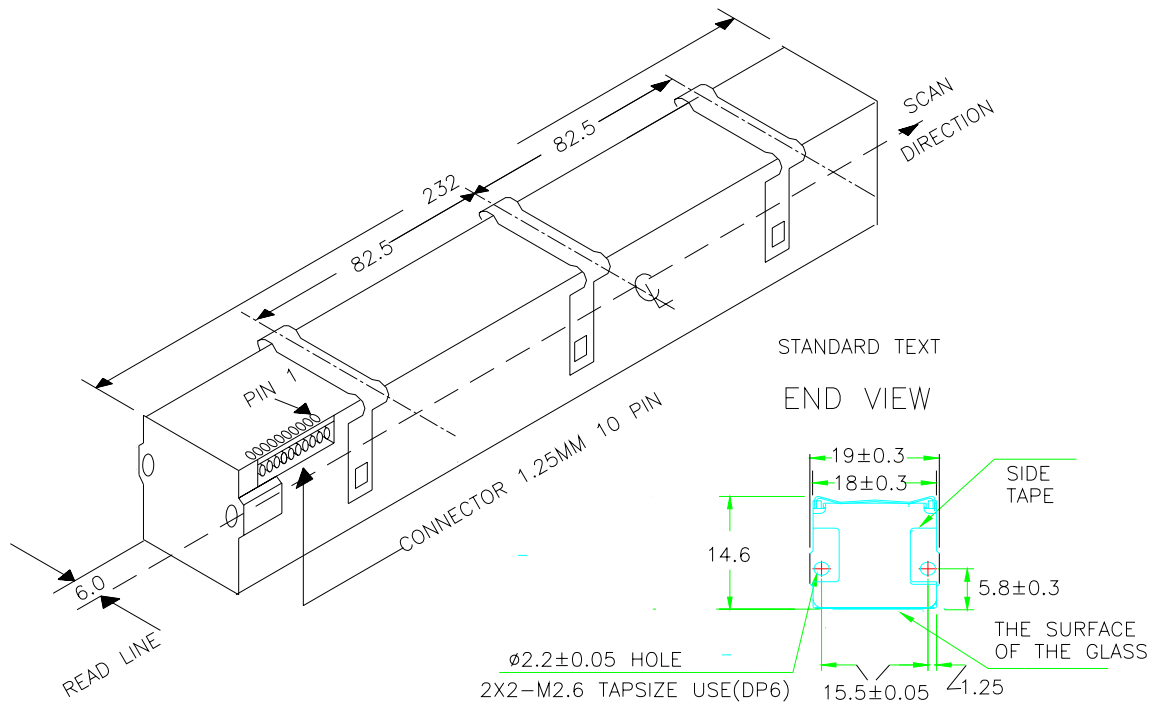

Figure 6. Module Mechanical Overview

©2004 Peripheral Imaging Corporation. Printed in USA. All rights reserved. Specifications are subject to change without notice. Contents may not be reproduced in whole or in part without the express prior written permission of Peripheral Imaging Corporation. Information furnished herein is believed to be accurate and reliable. However, no responsibility is assumed by Peripheral Imaging Corporation for its use nor for any infringement of patents or other rights granted by implication or otherwise under any patent or patent rights of Peripheral Imaging Corporation