

PCI 350

350 Watt CompactPCI Power Supply

 Tracewell**Power**

■ Features

- 350 Watts in 6U x 8HP (two slots) x 160mm
- Wide-range AC or 48 Volt DC input
- Standard PCI voltages: 5V, 3.3V, \pm 12V
- Four output-current options:

5V/40A	3.3V/25A	12V/9A	-12V/2A
5V/50A	3.3V/25A	12V/9A	-12V/2A
3.3V/50A	5V/20A	12V/9A	-12V/2A
3.3V/60A	5V/20A	12V/9A	-12V/2A

- Power factor correction (PFC)
- N+1 redundant and hot swap
- Internal OR-ing diodes
- Single-wire current sharing on 5V, 3.3V, +12V outputs
- Fully shielded
- IEEE1101.10 compliant front panels
- Ruggedized mechanical design
- Optional high-profile cooling fins available on 48V input version
- UL, cUL approved
- CE mark
- EMC approved
- Two year warranty

ISO 9001



PCI 350 AC input power supply shown with optional low-profile handles

■ Description

The PCI 350 is a high-performance power supply for use in 6U CompactPCI computer, test and telecom systems. The PCI 350 meets all of the requirements of the PICMG CompactPCI specification plus N+1 redundant and hot swap. High-density cooling fins are positioned directly in the airstream. All input and output connections are through the backplane. LED status indicators are located on the front panel.

PCI 350

350 Watt Compact PCI Power Supply



Specifications

Output Voltage/Current Options ... 5V/40A, 3.3V/25A, +12V/9A, -12V/2A
 5V/50A, 3.3V/25A, +12V/9A, -12V/2A
 3.3V/50A, 5V/20A, +12V/9A, -12V/2A
 3.3V/60A, 5V/20A, +12V/9A, -12V/2A

Output Power DC Input: 350 Watts max
 AC Input: 350 Watts max 105-264 Vac
 300 Watts max 90-105 Vac

Input Voltage/Current AC: 100-240 Vac (90-264 Vac tolerant range), 47-63Hz,
 6 A max, single phase
 DC: 48 Vdc (40-72 Vdc tolerant range), 12 A max

Power Factor 0.99 typical

Inrush Current AC: 40A max
 DC: 15A max

Efficiency DC input: 75% min
 AC input: 65% min
 Efficiency increases with line voltage

Holdup Time 20 msec min. from input power failure until FAIL# signal
 drops, at full load and 90-264 Vac

AC Fail Warning 5 msec min. continued operation after FAIL# signal drops

Paralleling Any number of power supplies can be operated in
 parallel and will share 3.3V/5V/+12V current to within
 10%. Remote Sense must be used when paralleling
 with current sharing

Redundant/Hot Swap Full power N+1 redundant and hot-swap

Remote Sense Compensates for up to 0.25V total distribution voltage
 drop on the 3.3V/5V/+12V outputs

Line/Load Regulation 1% max. over input range and 0-100% load except
 -12V output which is $\pm 10\%$

Minimum Load None required

Ripple/Noise 50 mV max. for all outputs, peak-to-peak, DC to 20 MHz
 with coaxial probe and 0.1uF/22uF capacitors at the
 connector

Overshoot/Undershoot None at turn-on or turn-off

Turn-on Time 1 sec max. from power up. All output voltages come
 up within 10 msec of each other.

Over-Voltage Shutdown at 130% of nominal Vout. Recycle power to
 reset

Over-Temperature Shutdown upon internal heatsink temperatures
 exceeding limits. Recycle power to reset

Current Limiting All outputs protected against overload and short circuit.
 Straight-line current limiting, does not fold-back or latch-
 up during startup or load transients. Automatic recovery

Safety UL, cUL, and CB report UL1950 and EN60950

EMC Emissions below EN55022 class A and EN61000-3-2, 3.
 Immunity to EN61000-4-2, 4, 5

Input Fuse Internal fusing included

Output Isolation All outputs and control signals are SELV circuits
 referenced to GND with reinforced insulation to the AC
 primary. GND should be connected to chassis ground
 in the system.

Leakage Current 1.0 mA max. at 240 Vac

Dielectric Strength AC: 2200 Vdc from input to chassis ground
 DC: 500 Vdc from input to chassis ground

Indicators Green LED indicating INPUT OK
 Red LED indicating a power supply FAULT

Connector Positronic part no. PCI38M400A1
 Mating connector part no. PCI38F300A1

Cooling 15 cfm/400 lfm forced air required through power
 supply cooling fins and enclosure

Operating Temperature -20°C to 50°C operating temperature with specified air
 flow. Derate output power with reduced airflow
 conditions (consult factory)

Storage Temperature -40°C to 85°C

Shock/Vibration Ruggedized construction

Note: Specifications subject to change without notice

PCI 350 Status Indications

Condition	Power Supply On/Off	Input OK LED	Fault LED	FAIL #
EN# low, Inputs/Outputs OK	ON	ON	OFF	OPEN
INH# signal low	OFF	ON	ON	LOW
INH# high, EN# high	OFF	ON	ON	LOW
Inhibit switch depressed	OFF	ON	ON	LOW
Low AC or DC input	OFF	OFF	ON*	LOW
Internal over-temperature	OFF	ON	ON	LOW
Output under-voltage	OFF**	ON	ON	LOW
Output over-voltage	OFF**	ON	ON	LOW
Output short circuit	OFF**	ON	ON	LOW

* If the input is below approx. 20 V, the FAULT LED will not illuminate
** Typically, only the output exhibiting the fault conditions will be off

PCI 350

350 Watt Compact PCI Power Supply



Output Power vs Temperature and Airflow

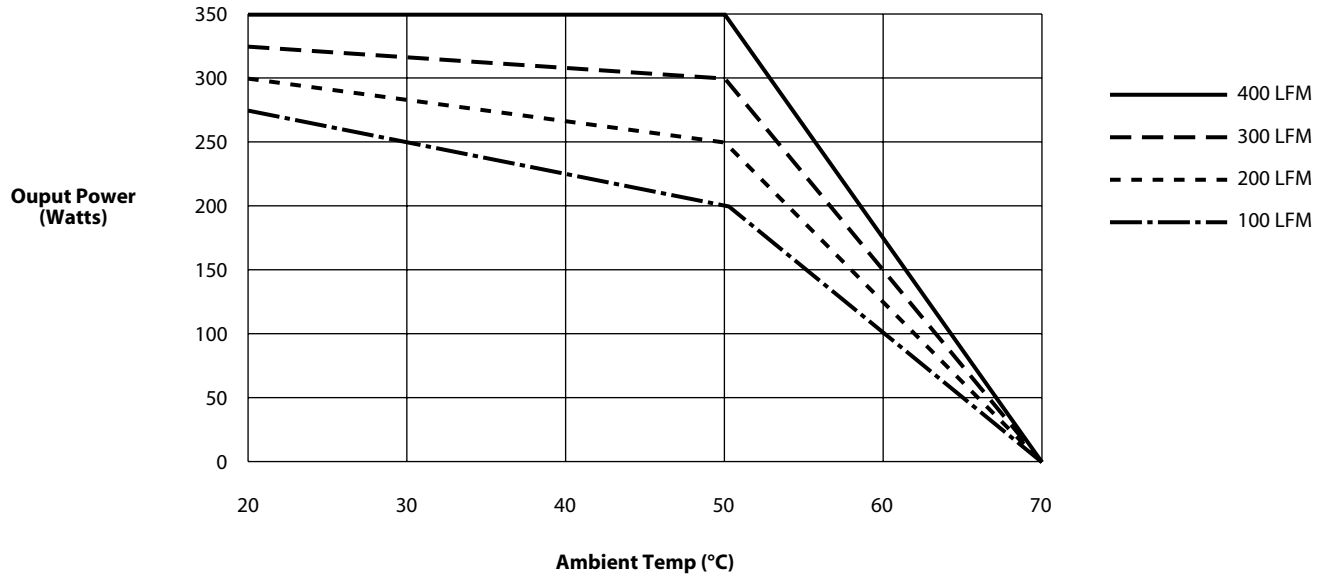

Note: LFM is the airflow in feet per minute through the power supply fins and enclosure

Connector Pinout

Pin #	Signal	Pin #	Signal	Description
1	+5V	24	+5S	Remote sense for +5V oputput
2	+5V	25	EN#	Connect to GND to enable power supply
3	+5V	26	-SENSE	Remote sense return for +3.3V, + 5V, +12V outputs
4	+5V	27	+3.3S	Remote sense for +3.3V output
5	GND	28	RSVD	RESERVED
6	GND	29	DEG#	Open collector, low output when power supply is within 10° C of shutting down due to over-temperature
7	GND	30	+12S	Remote sense for +12V output
8	GND	31	INH#	Connect to GND to inhibit power supply
9	GND	32	+5I	Connect to paralleled power supply for +5V current sharing
10	GND	33	+3.3I	Connect to paralleled power supply for +3.3V current sharing
11	GND	34	+12I	Connect to paralleled power supply for +12V current sharing
12	GND	35	FAIL#	Open collector, low output when power supply has failed
13	+3.3V	36	CGND	Chassis ground
14	+3.3V	37	N	Neutral (AC) or 48V return (DC)
15	+3.3V	38	L	Line (AC) or -48V (DC)
16	+3.3V			
17	GND			
18	+12V			
19	RSVD			
20	RSVD			
21	-12V			
22	GND			
23	GND			

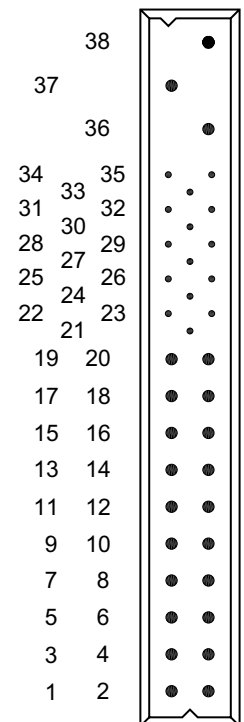

PCI 350

350 Watt CompactPCI Power Supply



■ Dimensions

AC and 48V
Input Versions

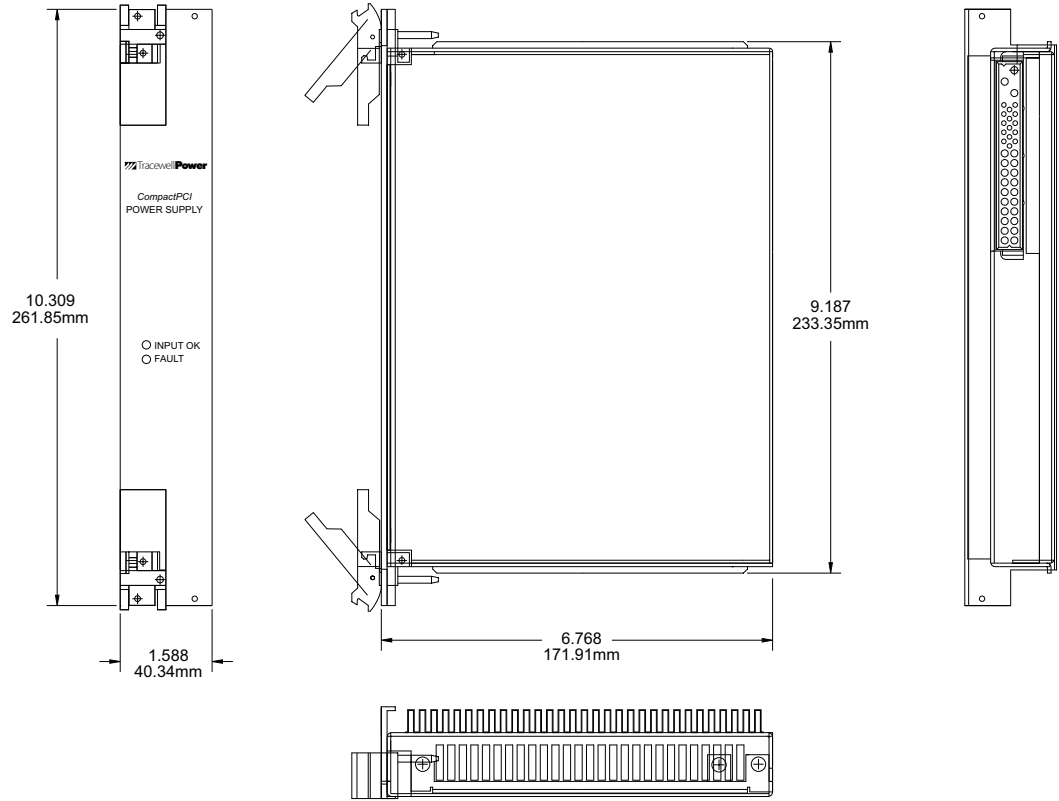

Optional High-Profile
Cooling Fin Version
(48V input only)

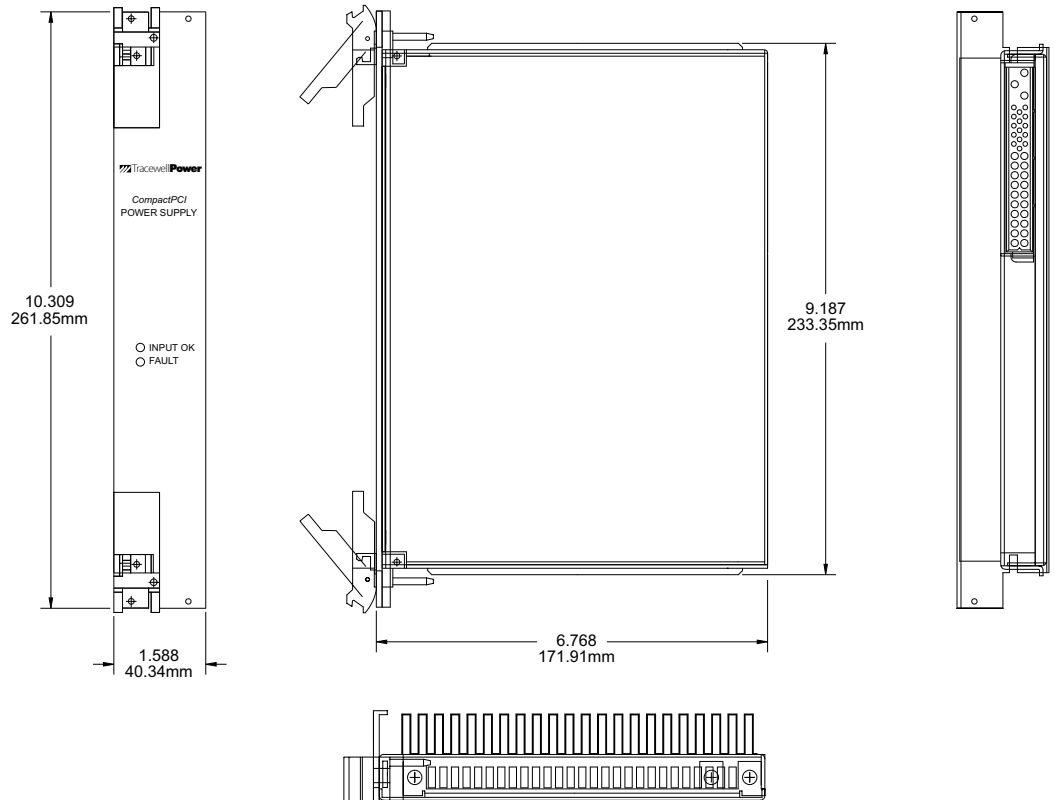

CompactPCI™ is a trademark of the
PCI Industrial Computer Manufacturer's Group

PCI 350

350 Watt CompactPCI Power Supply



Backplane Connector Location

Power backplanes are available for both the AC and 48V power supplies: 2-slot (for one power supply) and 4-slot (for two power supplies). Consult factory for details.

AC and 48V Input Versions

BACKPLANE POWER CONNECTOR LOCATION VIEWED FROM THE FRONT OF THE CAGE

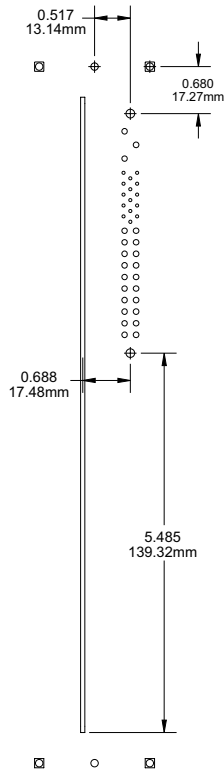

Optional High-Profile Cooling Fin Version (48V input only)

BACKPLANE POWER CONNECTOR LOCATION VIEWED FROM THE FRONT OF THE CAGE

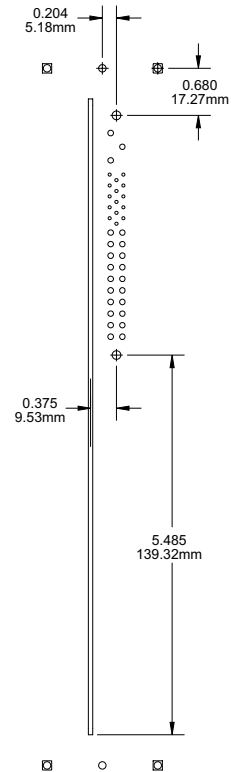

Note: Please reference Section 4 (Mechanical Requirements) of the CompactPCI Specification PICMG 2.0 R2.1

Configuration

PCI350 -

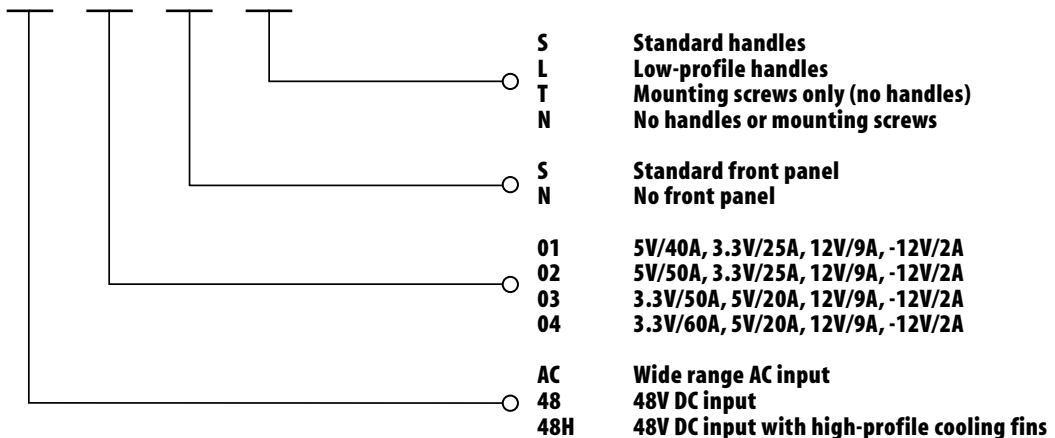

Example: PCI350-AC01SL AC version with 01 output configuration, standard front panel and low profile handles