

12-Character 4-Line Dot Matrix Low Power

LCD Controller Driver with key Scan Function

■ GENERAL DESCRIPTION

The NJU6475B is a Dot Matrix LCD Controller Driver for 12-character 4-line with Icon display in single chip. It contains voltage converter, voltage regulator, bleeder resistance, CR oscillator, instruction decoder, character generator ROM/RAM, high voltage operation controller/driver and key scan circuit.

The voltage converter generates (about 8V) from the supply voltage (3V) and regulated by the regulator. The bias level of LCD driving voltage is generated of high value bleeder resistance and the buffer amplifier matches the impedance. 16-step contrast control function is incorporated for its adjustment. Therefore, simple power supply circuit and easy contrast adjustment are available. The complete CR oscillator is incorporated without external components for oscillation circuit. The microprocessor interface circuit which operates by 1MHz, can be selected serial interface.

The character generator ROM consisting of 10,080bits stores 252 kinds of character Font.

Each 160bits CG RAM and Icon display RAM can store 4 kinds of special character to display on the dot matrix display area or 128 kinds of Icon on the display area.

■ PACKAGE OUTLINE

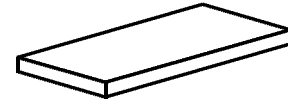

NJU6475B

■ FEATURES

- 12-Character 4-Line Dot Matrix LCD Controller Driver
- Maximum 128-Icon Display
- Serial CPU Interface
- Display Data RAM - 48 x 8 Bits :Maximum 12-Character 4-Line Display
- Character Generator ROM - 10,080 Bits:252 Characters (5 x 8 Dots)
- Character Generator RAM - 32 x 5 Bits :4 Patterns (5 x 8 Dots)
- Icon Display RAM - 32 x 5 Bits :Maximum 128-Icon
- High Voltage LCD Driver : 37-Common/63-Segment
- Duty & Bias Ratio : 1/36 duty 1/7Bias
- Useful Instruction Set : Clear Display, Return Home, Display On/Off Control
Display Blink, Cursor Shift, Character Shift
- Common and Segment Driver location Order Select Function (Mode-A, Mode-B)
- Power On Reset Circuit On Chip
- Hardware Reset
- Voltage Regulator On Chip
- Electrical Variable Resistance On Chip
- 32-key scan function (8 x 4 Matrix)
- Oscillation circuit On Chip
- Voltage Converter (Doubler, Tripler) On Chip
- Bleeder Resistance On Chip
- Low Operating Current
- Operating Voltage - 2.4V to 3.6V (Except For LCD Driving Voltage)
- Package Outline - Bumped-Chip / TCP
- C-MOS Technology

NJU6475B

■ PAD LOCATION

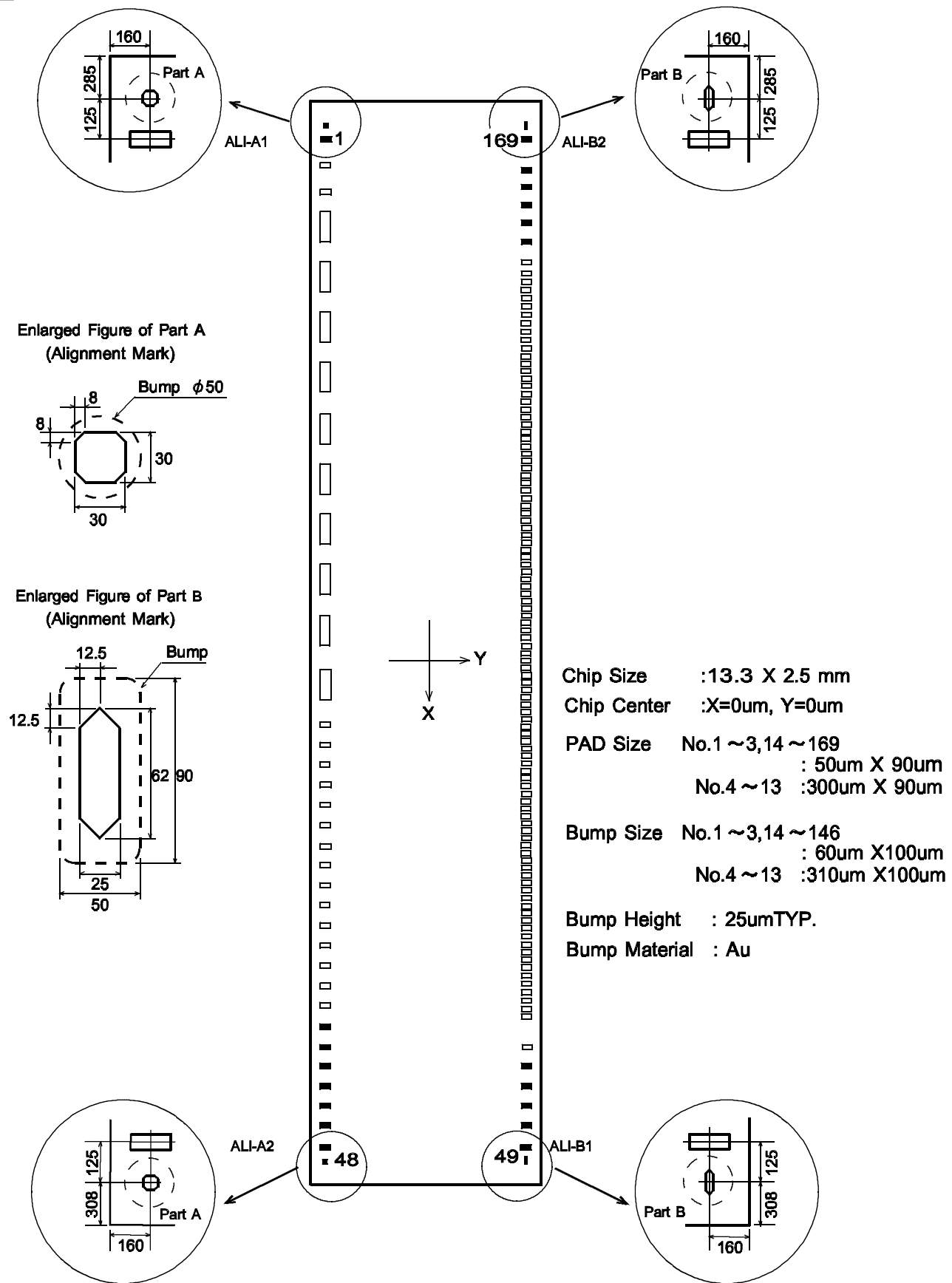

■ PAD COORDINATES

Chip Size 11.22x2.5mm (Chip Center X=0um,Y=0um)

PAD No.	PAD Name		X=(um)	Y=(um)
	Mode A	Mode B		
1	ALI-A1	ALI-A1	-6240	-1090
2	OSC ₁	OSC ₁	-6020	-1090
3	OSC ₂	OSC ₂	-5775	-1090
4	V ₅	V ₅	-5479	-1090
5	V _{SS}	V _{SS}	-4979	-1090
6	V _{SOUT}	V _{SOUT}	-4479	-1090
7	C2 ⁻	C2 ⁻	-3979	-1090
8	C2 ⁺	C2 ⁺	-3479	-1090
9	C1 ⁻	C1 ⁻	-2979	-1090
10	C1 ⁺	C1 ⁺	-2479	-1090
11	V _{DD}	V _{DD}	-1979	-1090
12	VR	VR	-1479	-1090
13	V _{REG}	V _{REG}	- 979	-1090
14	TEST	TEST	- 531	-1090
15	SEL	SEL	- 302	-1090
16	RESET	RESET	- 74	-1090
17	P/S	P/S	155	-1090
18	RS	RS	383	-1090
19	R/W	R/W	612	-1090
20	E/SCL	E/SCL	840	-1090
21	LCD/KEY	LCD/KEY	1069	-1090
22	REQ	REQ	1298	-1090
23	DB ₇ /CS	DB ₇ /CS	1536	-1090
24	DB ₆ /SIO	DB ₆ /SIO	1773	-1090
25	DB ₅	DB ₅	2010	-1090
26	DB ₄	DB ₄	2247	-1090
27	DB ₃	DB ₃	2484	-1090
28	DB ₂	DB ₂	2721	-1090
29	DB ₁	DB ₁	2958	-1090
30	DB ₀	DB ₀	3195	-1090
31	K ₀	K ₀	3466	-1090
32	K ₁	K ₁	3632	-1090
33	K ₂	K ₂	3903	-1090
34	K ₃	K ₃	4068	-1090
35	S ₀	S ₀	4244	-1090
36	S ₁	S ₁	4352	-1090
37	S ₂	S ₂	4460	-1090
38	S ₃	S ₃	4568	-1090
39	S ₄	S ₄	4676	-1090
40	S ₅	S ₅	4784	-1090
41	S ₆	S ₆	4892	-1090
42	S ₇	S ₇	5000	-1090
43	NC	NC	5217	-1090
44	NC	NC	5417	-1090
45	NC	NC	5617	-1090
46	NC	NC	5817	-1090
47	NC	NC	6017	-1090
48	ALI-A2	ALI-A2	6217	-1090
49	ALI-B2	ALI-B2	6217	1090
50	NC	NC	6017	1090

PAD No.	PAD Name		X=(um)	Y=(um)
	Mode A	Mode B		
51	NC	NC	5817	1090
52	NC	NC	5617	1090
53	NC	NC	5417	1090
54	NC	NC	5217	1090
55	NC	NC	5017	1090
56	NC	NC	4817	1090
57	NC	NC	4617	1090
58	NC	NC	4417	1090
59	NC	NC	4217	1090
60	NC	NC	4017	1090
61	NC	NC	3817	1090
62	NC	NC	3617	1090
63	NC	NC	3417	1090
64	SEGS ₁	SEGS ₁	3160	1090
65	COM ₉	COM ₉	2780	1090
66	COM ₁₀	COM ₁₀	2700	1090
67	COM ₁₁	COM ₁₁	2620	1090
68	COM ₁₂	COM ₁₂	2540	1090
69	COM ₁₃	COM ₁₃	2460	1090
70	COM ₁₄	COM ₁₄	2380	1090
71	COM ₁₅	COM ₁₅	2300	1090
72	COM ₁₆	COM ₁₆	2220	1090
73	COM ₂₅	COM ₂₅	2140	1090
74	COM ₂₆	COM ₂₆	2060	1090
75	COM ₂₇	COM ₂₇	1980	1090
76	COM ₂₈	COM ₂₈	1900	1090
77	COM ₂₉	COM ₂₉	1820	1090
78	COM ₃₀	COM ₃₀	1740	1090
79	COM ₃₁	COM ₃₁	1660	1090
80	COM ₃₂	COM ₃₂	1580	1090
81	SEGM ₁	SEGM ₂	1500	1090
82	SEG ₁	SEG ₆₀	1420	1090
83	SEG ₂	SEG ₅₉	1340	1090
84	SEG ₃	SEG ₅₈	1260	1090
85	SEG ₄	SEG ₅₇	1180	1090
86	SEG ₅	SEG ₅₆	1100	1090
87	SEG ₆	SEG ₅₅	1020	1090
88	SEG ₇	SEG ₅₄	940	1090
89	SEG ₈	SEG ₅₃	860	1090
90	SEG ₉	SEG ₅₂	780	1090
91	SEG ₁₀	SEG ₅₁	700	1090
92	SEG ₁₁	SEG ₅₀	620	1090
93	SEG ₁₂	SEG ₄₉	540	1090
94	SEG ₁₃	SEG ₄₈	460	1090
95	SEG ₁₄	SEG ₄₇	380	1090
96	SEG ₁₅	SEG ₄₆	300	1090
97	SEG ₁₆	SEG ₄₅	220	1090
98	SEG ₁₇	SEG ₄₄	140	1090
99	SEG ₁₈	SEG ₄₃	60	1090
100	SEG ₁₉	SEG ₄₂	- 20	1090

NJU6475B

PAD No.	PAD Name		X=(um)	Y=(um)
	Mode A	Mode B		
101	SEG ₂₀	SEG ₄₁	- 100	1090
102	SEG ₂₁	SEG ₄₀	- 180	1090
103	SEG ₂₂	SEG ₃₉	- 260	1090
104	SEG ₂₃	SEG ₃₈	- 340	1090
105	SEG ₂₄	SEG ₃₇	- 420	1090
106	SEG ₂₅	SEG ₃₆	- 500	1090
107	SEG ₂₆	SEG ₃₅	- 580	1090
108	SEG ₂₇	SEG ₃₄	- 660	1090
109	SEG ₂₈	SEG ₃₃	- 740	1090
110	SEG ₂₉	SEG ₃₂	- 820	1090
111	SEG ₃₀	SEG ₃₁	- 900	1090
112	SEG ₃₁	SEG ₃₀	- 980	1090
113	SEG ₃₂	SEG ₂₉	-1060	1090
114	SEG ₃₃	SEG ₂₈	-1140	1090
115	SEG ₃₄	SEG ₂₇	-1220	1090
116	SEG ₃₅	SEG ₂₆	-1300	1090
117	SEG ₃₆	SEG ₂₅	-1380	1090
118	SEG ₃₇	SEG ₂₄	-1460	1090
119	SEG ₃₈	SEG ₂₃	-1540	1090
120	SEG ₃₉	SEG ₂₂	-1620	1090
121	SEG ₄₀	SEG ₂₁	-1700	1090
122	SEG ₄₁	SEG ₂₀	-1780	1090
123	SEG ₄₂	SEG ₁₉	-1860	1090
124	SEG ₄₃	SEG ₁₈	-1940	1090
125	SEG ₄₄	SEG ₁₇	-2020	1090
126	SEG ₄₅	SEG ₁₆	-2100	1090
127	SEG ₄₆	SEG ₁₅	-2180	1090
128	SEG ₄₇	SEG ₁₄	-2260	1090
129	SEG ₄₈	SEG ₁₃	-2340	1090
130	SEG ₄₉	SEG ₁₂	-2420	1090
131	SEG ₅₀	SEG ₁₁	-2500	1090
132	SEG ₅₁	SEG ₁₀	-2580	1090
133	SEG ₅₂	SEG ₉	-2660	1090
134	SEG ₅₃	SEG ₈	-2740	1090

PAD No.	PAD Name		X=(um)	Y=(um)
	Mode A	Mode B		
135	SEG ₅₄	SEG ₇	-2820	1090
136	SEG ₅₅	SEG ₆	-2900	1090
137	SEG ₅₆	SEG ₅	-2980	1090
138	SEG ₅₇	SEG ₄	-3060	1090
139	SEG ₅₈	SEG ₃	-3140	1090
140	SEG ₅₉	SEG ₂	-3220	1090
141	SEG ₆₀	SEG ₁	-3300	1090
142	SEGM ₂	SEGM ₁	-3380	1090
143	COM ₂₄	COM ₂₄	-3460	1090
144	COM ₂₃	COM ₂₃	-3540	1090
145	COM ₂₂	COM ₂₂	-3620	1090
146	COM ₂₁	COM ₂₁	-3700	1090
147	COM ₂₀	COM ₂₀	-3780	1090
148	COM ₁₉	COM ₁₉	-3860	1090
149	COM ₁₈	COM ₁₈	-3940	1090
150	COM ₁₇	COM ₁₇	-4020	1090
151	COM ₈	COM ₈	-4100	1090
152	COM ₇	COM ₇	-4180	1090
153	COM ₆	COM ₆	-4260	1090
154	COM ₅	COM ₅	-4340	1090
155	COM ₄	COM ₄	-4420	1090
156	COM ₃	COM ₃	-4500	1090
157	COM ₂	COM ₂	-4580	1090
158	COM ₁	COM ₁	-4660	1090
159	COMM ₄	COMM ₄	-4740	1090
160	COMM ₃	COMM ₃	-4820	1090
161	COMM ₂	COMM ₂	-4900	1090
162	COMM ₁	COMM ₁	-4980	1090
163	COMS ₁	COMS ₁	-5085	1090
164	NC	NC	-5285	1090
165	NC	NC	-5485	1090
167	NC	NC	-5885	1090
168	NC	NC	-6085	1090
169	ALI-B2	ALI-B2	-6240	1090

■ BLOCK DIAGRAM

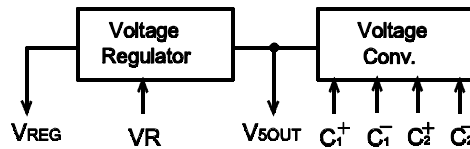
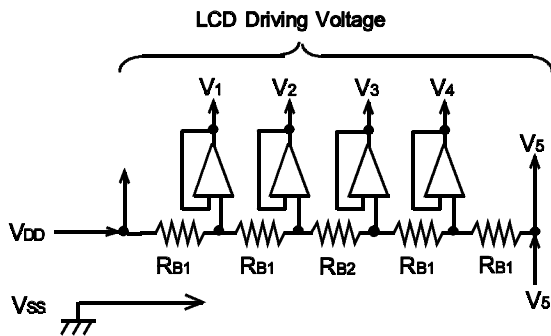
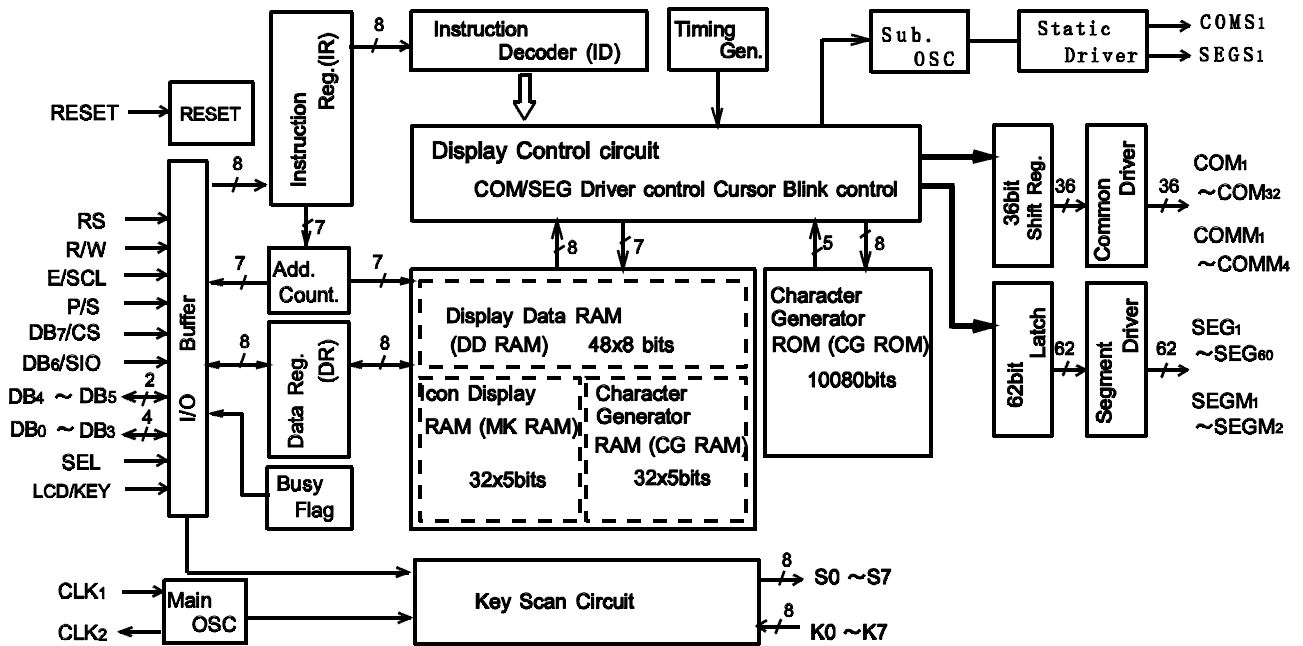

NJU6475B

■ TERMINAL DESCRIPTION

PAD No.	Symbol	I/O	F u n c t i o n
11,5	V_{DD}, V_{SS}	-	Power Source : $V_{DD}=+3V$ GND : $V_{SS}=0V$
4	V_5	-	LCD driving voltage
2,3	OSC ₁ , OSC ₂	I/O	System clock terminal Oscillation C and R are incorporated. (Normally Open) For external clock operation, the clock should be input on OSC ₁ .
17	P/S	I	Serial input select terminal (fixed to "L")
18	RS	I	Register selection signal input terminal "0" instruction register. (Writing) "1" Data register. (Writing, Reading)
19	R/W	I	Read(R) / Write(W) selection signal input terminal
20	E/SCL	I	Serial clock input terminal
23	DB ₇ /CS	I	Chip select signal
24	DB ₆ /SIO	I/O	Data input terminal (3-state data bus.)
25 - 30	DB ₀ - DB ₅	I	I/O port output terminal
22	REQ	O	This terminal normally output "L". When confirm a key action, REQ terminal output puls.
21	LCD/KEY	I	Fix to "H" Level
35 - 42	S ₀ - S ₇	O	Key scan signal data output terminal Open Drain Output
31 - 34	K ₀ - K ₃	I	Key scan data input terminal In case of non use, fix to "H".
158 - 151 65 - 72 150 - 143 73 - 80	COM ₁ - COM ₃₂	O	Common signal output terminal
162 - 159	COMM ₁ - COMM ₄	O	Icon common display signal output terminal
163	COMS ₁	O	Static driving common signal output terminal When power down mode V_{DD} or V_{SS} levels are output.
82 - 141	SEG ₁ - SEG ₆₀	O	Segment signal output terminal
81,142	SEGM ₁ ,SEGM ₂	O	Icon segment driving signal output terminal

PAD No.	Symbol	I/O	F u n c t i o n
57	SEGS _i	O	Static driving segment signal output terminal When power down mode V _{DD} or V _{SS} level are output.
10,9 8,7	C1 ⁺ , C1 ⁻ C2 ⁺ , C2 ⁻	I/O	Step up voltage capacitor connecting terminal
6	V _{SOUT}	O	Step up voltage output terminal
13	V _{REG}	O	Voltage regulator output terminal Connect the resistor between this terminal and VR terminal.
12	VR	I	Reference voltage for voltage regulator input terminal Connect the resistor between this reference voltage and V _{DD} terminal.
16	<u>RESET</u>	I	Reset terminal When the "L" level input over than 1.2ms to this terminal, the system is reset (at f _{osc} =180KHz).
15	SEL	I	Common and Segment driver location order select terminal. "0" Mode A location (See ■ PAD COORDINATES) "1" Mode B location (See ■ PAD COORDINATES)
14	TEST	I	Maker test terminal This terminal should be connected to V _{SS} (or open.)
43 - 47 50 - 63 164 - 168	NC	-	Non connection terminal These terminals are electrically open.
169 49 1 48	ALI-A1 ALI-A2 ALI-B1 ALI-B2	-	Alignment mark These terminals are electrically open.

NJU6475B

■ FUNCTIONAL DESCRIPTION

(1) Description for each blocks

(1-1) Register

The NJU6475B incorporates three 8-bit registers, an instruction register (IR), and a Data Register (DR), Key Register (KR). The register (IR) stores an instruction code such as "clear display" and "cursor shift" or address data for Display Data RAM (DD RAM), Character Generator RAM (CG RAM) and Icon Display RAM (MK RAM). The MPU can write the instruction code and address data to the register (IR), but it cannot read out from register (IR). The Register (DR) is a temporary register, the data stored in the Register (DR) is written into DD RAM, MK RAM. A register from these two registers is selected by the register select signal (RS). Register (KR) is an only temporary register for key scan data. This Register (KR) can read out the contents when selected Key signal at "H" signal. And non relationship with signal of register select (RS).

The Relation ship with RS, R/W register as shown below.

<Table-1> Register selection

RS	R/W	O p e r a t i o n
0	0	IR write & internal register operation mode (Clear Display etc...)
0	1	Read out (KR)
1	0	Write (DR) & internal register operation mode (DR→ DD RAM/CG RAM/MK RAM)
1	1	Read out (KR)

(1-2) Address Counter (AC)

The address counter (AC) addresses the DD RAM, CG RAM or MK RAM. When the address setting instruction is written into register (IR), the address information is transferred from register (IR) to the address counter (AC). The selection of DD RAM, CG RAM or MK RAM is also determined by this instruction.

After writing (or reading) the display data to (or from) the DD RAM, CG RAM or MK RAM, the address counter (AC) increments (or decrements) automatically.

(1-3) Display Data RAM (DD RAM)

The display data RAM (DD RAM) consisting of 48 x 8 bits stores up to 48-character display data represented in 8-bit code.

The DD RAM address data set in the address counter (AC) is represented in Hexadecimal code.

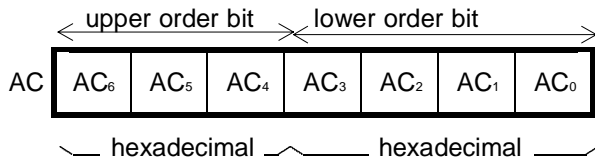

(Example) DD RAM Address "08"

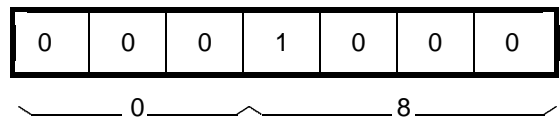

(1-3-1) The relation between DD RAM address and display position on the LCD

-12-Characters 4-Line Display

	1	2	3	4	5	6	7	8	9	10	11	12	← Display Position
1st Line	00	01	02	03	04	05	06	07	08	09	0A	0B	← DD RAM Address (Hexadecimal)
2nd Line	10	11	12	13	14	15	16	17	18	19	1A	1B	
3rd Line	20	21	22	23	24	25	26	27	28	29	2A	2B	
4th Line	30	31	32	33	34	35	36	37	38	39	3A	3B	

When the display shift is performed, the DD RAM address changes as follows:

[Left shift display]

(00) ←	01	02	03	04	05	06	07	08	09	0A	0B	00
(10) ←	11	12	13	14	15	16	17	18	19	1A	1B	10
(20) ←	21	22	23	24	25	26	27	28	29	2A	2B	20
(30) ←	31	32	33	34	35	36	37	38	39	3A	3B	30

[Right shift display]

0B	00	01	02	03	04	05	06	07	08	09	0A	→ (0B)
1B	10	11	12	13	14	15	16	17	18	19	1A	→ (1B)
2B	20	21	22	23	24	25	26	27	28	29	2A	→ (2B)
3B	30	31	32	33	34	35	36	37	38	39	3A	→ (3B)

(1-4) Character Generator ROM (CG ROM)

The Character Generator ROM (CG ROM) stores 5 x 8 dots character pattern represented in 8-bit character code. The capacity is up to 252 kinds of 5 x 8 dots character pattern.

The correspondence between character code and standard character pattern of NJU6475B is shown in table 2.

User defined character patterns (Custom Font) are also available by mask option. (in this case, the address (20)_H are using for "Space Pattern".)

<Table-2> The Correspondence Between Character Code
and Standard Character Pattern (ROM Version -02)

		Upper 4 bit (Hexadecimal)															
		0	1	2	3	4	5	6	7	8	9	A	B	C	D	E	F
Lower 4 bit (Hexadecimal)	0 CG RAM (01)	Ⓐ		⓪	Ⓜ	Ⓟ	Ⓠ	Ⓡ	Ⓢ	Ⓣ	Ⓤ	Ⓥ	Ⓦ	Ⓧ	Ⓨ	Ⓩ	ⓐ
	1 (02)	ⓑ	!	1	Ⓐ	Ⓡ	Ⓢ	Ⓣ	Ⓤ	Ⓥ	Ⓦ	Ⓧ	Ⓨ	Ⓩ	ⓐ	ⓑ	Ⓒ
	2 (03)	Ⓐ	"	2	Ⓐ	Ⓡ	Ⓢ	Ⓣ	Ⓤ	Ⓥ	Ⓦ	Ⓧ	Ⓨ	Ⓩ	ⓐ	ⓑ	Ⓒ
	3 (04)	1	#	3	Ⓐ	Ⓡ	Ⓢ	Ⓣ	Ⓤ	Ⓥ	Ⓦ	Ⓧ	Ⓨ	Ⓩ	ⓐ	ⓑ	Ⓒ
	4	ó	\$	4	Ⓐ	Ⓡ	Ⓢ	Ⓣ	Ⓤ	Ⓥ	Ⓦ	Ⓧ	Ⓨ	Ⓩ	ⓐ	ⓑ	Ⓒ
	5	ó	%	5	Ⓐ	Ⓡ	Ⓢ	Ⓣ	Ⓤ	Ⓥ	Ⓦ	Ⓧ	Ⓨ	Ⓩ	ⓐ	ⓑ	Ⓒ
	6	Ⓐ	&	6	Ⓐ	Ⓡ	Ⓢ	Ⓣ	Ⓤ	Ⓥ	Ⓦ	Ⓧ	Ⓨ	Ⓩ	ⓐ	ⓑ	Ⓒ
	7	Ⓐ	'	7	Ⓐ	Ⓡ	Ⓢ	Ⓣ	Ⓤ	Ⓥ	Ⓦ	Ⓧ	Ⓨ	Ⓩ	ⓐ	ⓑ	Ⓒ
	8	Ⓐ	<	8	Ⓐ	Ⓡ	Ⓢ	Ⓣ	Ⓤ	Ⓥ	Ⓦ	Ⓧ	Ⓨ	Ⓩ	ⓐ	ⓑ	Ⓒ
	9	Ⓐ)	9	Ⓐ	Ⓡ	Ⓢ	Ⓣ	Ⓤ	Ⓥ	Ⓦ	Ⓧ	Ⓨ	Ⓩ	ⓐ	ⓑ	Ⓒ
	A	Ⓐ	*	:	Ⓐ	Ⓡ	Ⓢ	Ⓣ	Ⓤ	Ⓥ	Ⓦ	Ⓧ	Ⓨ	Ⓩ	ⓐ	ⓑ	Ⓒ
	B	Ⓐ	+	:	Ⓐ	Ⓡ	Ⓢ	Ⓣ	Ⓤ	Ⓥ	Ⓦ	Ⓧ	Ⓨ	Ⓩ	ⓐ	ⓑ	Ⓒ
	C	Ⓐ	,	<	Ⓐ	Ⓡ	Ⓢ	Ⓣ	Ⓤ	Ⓥ	Ⓦ	Ⓧ	Ⓨ	Ⓩ	ⓐ	ⓑ	Ⓒ
	D	Ⓐ	-	=	Ⓐ	Ⓡ	Ⓢ	Ⓣ	Ⓤ	Ⓥ	Ⓦ	Ⓧ	Ⓨ	Ⓩ	ⓐ	ⓑ	Ⓒ
	E	Ⓐ	.	>	Ⓐ	Ⓡ	Ⓢ	Ⓣ	Ⓤ	Ⓥ	Ⓦ	Ⓧ	Ⓨ	Ⓩ	ⓐ	ⓑ	Ⓒ
	F	Ⓐ	/	?	Ⓐ	Ⓡ	Ⓢ	Ⓣ	Ⓤ	Ⓥ	Ⓦ	Ⓧ	Ⓨ	Ⓩ	ⓐ	ⓑ	Ⓒ

(1-5) Character Generator RAM (CG RAM)

The Character Generator RAM stores any kinds of character pattern in 5 x 8 dots written by the user program to display user's original character pattern. The CG RAM can store 4 kinds of character in 5 x 8 dots mode.

To display user's original character pattern stored in the CG RAM, the address data (00)_H-(03)_H should be written to the DD RAM as shown in Table-3.

<Table-3> Correspondence of CG RAM address, DD RAM character code and CG RAM character pattern (5 x 8 dots)

Character Code (DD RAM Data)	CG RAM Address		Character Pattern (CG RAM Data)	
7 6 5 4 3 2 1 0 ← Upper Bits Lower Bits →	7 6 5 4 3 2 1 0 ← Upper Lower →	4 3 2 1 0 ← Upper Lower →		
0 0 0 0 0 0 0 0	0 1 0 0 0	0 0 0 0 0 1 0 1 0 0 1 1 1 0 0 1 0 1 1 1 0 1 1 1	1 1 1 1 0 1 0 0 0 1 1 0 0 0 1 1 1 1 1 0 1 0 1 0 0 1 0 0 1 0 1 0 0 0 1 0 0 0 0 0	Character Pattern Example (1) ← Cursor Position
0 0 0 0 0 0 0 1	0 1 0 0 1	0 0 0 0 0 1 0 1 0 0 1 1 1 0 0 1 0 1 1 1 0 1 1 1	1 0 0 0 1 0 1 0 1 0 1 1 1 1 1 0 0 1 0 0 1 1 1 1 1 0 0 1 0 0 0 0 1 0 0 0 0 0 0 0	Character Pattern Example (2) ← Cursor Position
		0 0 0 0 0 1		
0 0 0 0 0 0 1 1	0 1 0 1 1	1 0 0 1 0 1 1 1 0 1 1 1		

- Notes :
1. Character code bit 0,1 correspond to the CG RAM address bit 3,4 (2bits ; 4patterns).
 2. CG RAM address 0 to 2 designate character pattern line position. The 8th line should be "0".
If there is "1" in the 8th line, but bit "1" is always displayed on the cursor position regardless of cursor existence.
 3. Row position character pattern correspond to CG RAM data bits 0 to 4 are shown above.
 4. CG RAM character patterns are selected when character code bits 2 to 7 are all "0" and these are addressed by character code bits "0" and "1".
 5. "1" for CG RAM data corresponds to display on and "0" to display off.

NJU6475B

(1-6) Icon display RAM (MK RAM)

The NJU6475B can display maximum 128 Icons.

The Icon display can be controlled by writing the data into MK RAM corresponding to the Icons.

The relation between MK RAM address and Icon display position is shown in Table-4.

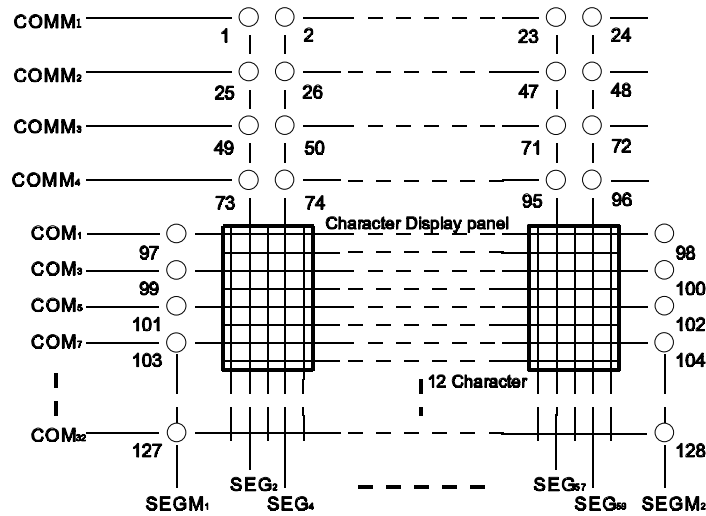

<Table-4> Correspondence among Icon Position, MK RAM Address and Data

MK RAM Address (60 _H - 7F _H)	Bits for Icon Position MK RAM Address and Data								
	D ₇	D ₆	D ₅	D ₄	D ₃	D ₂	D ₁	D ₀	
0110 0000	60 _H	*	*	*	1	2	3	4	97
0110 0001	61 _H	*	*	*	5	6	7	8	98
⋮	⋮								
0110 0101	65 _H	*	*	*	21	22	23	24	102
0110 0110	66 _H	*	*	*	*	*	*	*	103
0110 0111	67 _H	*	*	*	*	*	*	*	104
0110 1000	68 _H	*	*	*	25	26	27	28	105
0110 1001	69 _H	*	*	*	29	30	31	32	106
⋮	⋮								
0110 1101	6D _H	*	*	*	45	46	47	48	110
0110 1110	6E _H	*	*	*	*	*	*	*	111
0110 1111	6F _H	*	*	*	*	*	*	*	112
0111 0000	70 _H	*	*	*	49	50	51	52	113
0111 0001	71 _H	*	*	*	53	54	55	56	114
⋮	⋮								
0111 0101	75 _H	*	*	*	69	70	71	72	118
0111 0110	76 _H	*	*	*	*	*	*	*	119
0111 0111	77 _H	*	*	*	*	*	*	*	120
0111 1000	78 _H	*	*	*	73	74	75	76	121
0111 1001	79 _H	*	*	*	77	78	79	80	122
⋮	⋮								
0111 1101	7D _H	*	*	*	93	94	95	96	126
0111 1110	7E _H	*	*	*	*	*	*	*	127
0111 1111	7F _H	*	*	*	*	*	*	*	128

} COMM₁ Line and
 Both besides of 1st Line
 (COM₁, COM₃, COM₅, COM₇)

 } COMM₂ Line and
 Both besides of 2nd Line
 (COM₉, COM₁₁, COM₁₃, COM₁₅)

 } COMM₃ Line and
 Both besides of 3rd Line
 (COM₁₇, COM₁₉, COM₂₁, COM₂₃)

 } COMM₄ Line and
 Both besides of 4th Line
 (COM₂₅, COM₂₇, COM₂₉, COM₃₁)

- Notes :
1. When the Icon display function using, the system should be initialized by the software initialization. Because the MK RAM is not initialized by the power on reset and hardware.
 2. The cross-points between segments (SEGM₁ and SEGM₂) and commons (COMM₁ to COMM₄ and COM₂ to COM₃₂) are always set "OFF" level.
 3. In the table 4, * mark are invalid, therefore both of "0" or "1" can be written but these are no meaning.

(1-7) Timing generator

The timing generator generates a timing signals for the DD RAM, CG RAM and MK RAM and other internal circuits. RAM and timing for the display and internal operation timing for MPU access are separately generated, so that may not interfere with each other.

Therefore, when the data write to the DD RAM for example, there will be undesirable influence, such as flickering, in areas other than display area.

(1-8) LCD Driver

LCD Driver consists of 37-common driver and 63-segment driver. The character pattern data are latched to the addressed segment-register respectively.

This latched data controls display driver to output LCD driving waveform.

(1-9) Cursor Blinking control circuit

This circuit controls cursor On / Off and cursor position character blinking. The cursor or blinking appear in the digit locating at the DD RAM address set in the address counter (AC). When the address counter is (08)_H, a cursor position is shown as bellow.

	AC ₆	AC ₅	AC ₄	AC ₃	AC ₂	AC ₁	AC ₀
AC	0	0	0	1	0	0	0

4-Line Display

	1	2	3	4	5	6	7	8	9	10	11	12	← Display position
1st Line	00	01	02	03	04	05	06	07	<u>08</u>	09	0A	0B	← DD RAM Address (Hexadecimal)
2nd Line	10	11	12	13	14	15	16	17	18	19	1A	1B	
3rd Line	20	21	22	23	24	25	26	27	28	29	2A	2B	
4th Line	30	31	32	33	34	35	36	37	38	39	3A	3B	

↖
Cursor position

Note : The cursor or blinking also appear when the address counter (AC) selects the CG RAM or the MK RAM. But the displayed cursor and blinking are meaningless.

If the AC stores the CG or MK RAM address data, the cursor and blinking are displayed in the meaningless position.

NJU6475B

(2) Power on Initialization by internal circuits

(2-1) Internal Reset circuits Initialization

The NJU6475B is automatically initialized by internal power on initialization circuits when the power is turned on. In the internal power on initialization, following instructions are executed.

During the Internal power on initialization, the busy flag (BF) is "1" and this status is kept during 6ms ($f_{osc}=180\text{KHz}$) after V_{DD} rose to 2.4V.

Initialization sequence

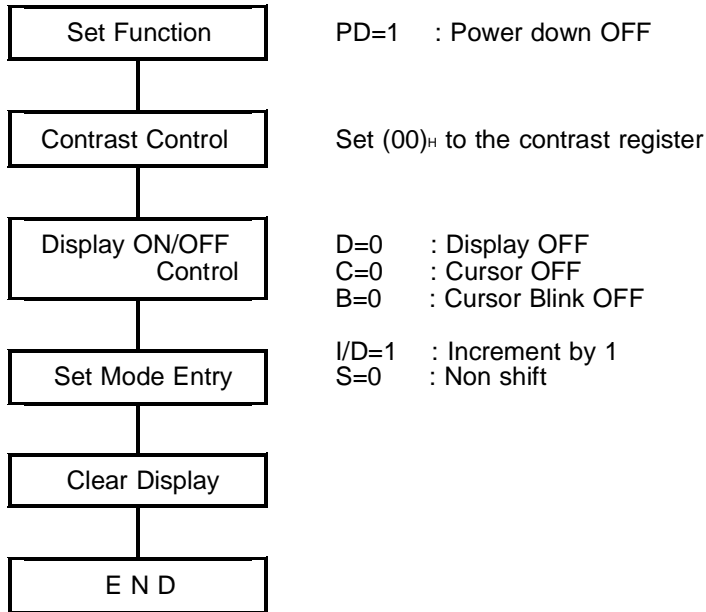

Note : If the condition of power supply rise time described in the Electrical Characteristics is not satisfied, the internal Power On Initialization will not performed. In this case, the software initialization by MPU is required.

(2-2) Hardware Initialization

The NJU6475B prepares RESET terminal to initialize the all system.

When the "L" level is input over 1.2ms to the RESET terminal, reset sequence is executed. In this time, the busy signal is output during 6ms ($f_{osc}=180\text{KHz}$) after RESET terminal went to "H".

-Timing Chart

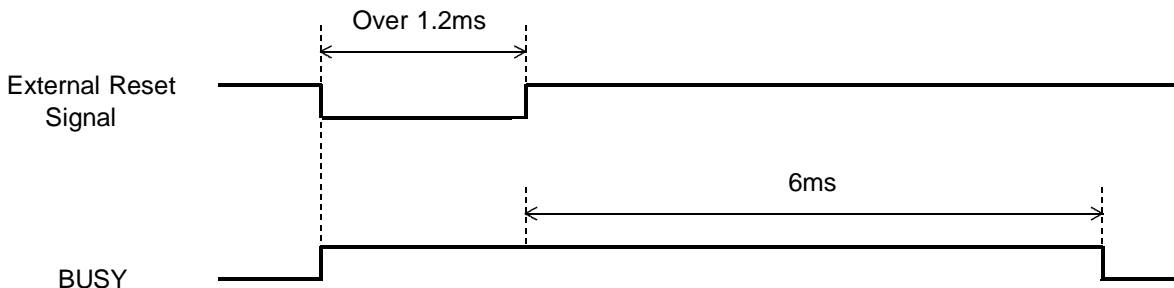

(3) Instruction

The NJU6475B incorporates two registers, an Instruction Register (IR) and a Data Register (DR). These two registers store control information temporarily to allow interface between NJU6475B and MPU or peripheral IC operating different cycles. The operation of NJU6475B is determined by this control signal from MPU.

The control information includes register selection signals (RS), Read / Write signals (R/W) and data signal (SIO).

<Table-5> shows each instruction and its operating time

Instruction	C o d e										Description	Execute Time (f _{CP} or f _{OSC} (MAX) =180kHz)
	RS	R/W	DB ₇	DB ₆	DB ₅	DB ₄	DB ₃	DB ₂	DB ₁	DB ₀		
Maker Test	0	0	0	0	0	0	0	0	0	0	All "0" code is using for maker testing.	-
Clear Display	0	0	0	0	0	0	0	0	0	1	Clears Display and sets RAM address (00) _H in AC.	5.42ms
Return Home	0	0	0	0	0	0	0	0	1	*	Sets RAM address (00) _H in AC and returns shifted display to original position. RAM contents are not changed	83.4us
Entry Mode Set	0	0	0	0	0	0	0	1	I/D	S	sets cursor move direction and display shift operation which are performed at data read/write.	0us
Display ON/OFF Control	0	0	0	0	0	0	1	D	C	B	Set Display Control On /Off (D), cursor On /Off (C) and character blinking (B) at cursor position.	0us
Cursor or Display Shift	0	0	0	0	0	1	S/C	R/L	*	*	moves cursor and shifts display without changing RAM(DR) contents.	Cursor : 83.4us Display : 0us
Function Set	0	0	0	0	1	*	*	*	*	PD	Sets Interface data length (DL) and power down mode (PD).	0us
Electronic Volume Register Set	0	0	0	1	*	*	Electronic volume			Sets Vreg data to EVR control register.	0us	
RAM Address Set	0	0	1	Address							Sets RAM Address. After this instruction, the data is transferred to/from RAM.	83.4us
Key Data Read	0	1	Read Data (KEY DATA)							When LCD/Key= "1", reads key data out.	0us	
Data Write to CG or DD or MK RAM	1	0	Write Data (DD RAM)							Writes data into DD or CG or MK RAM.	83.4us	
			*	*	*	(CG RAM)						
			(MK RAM)									
* : Don't care	I/D=1:Increment, I/D=0:Decrement, S=1:Include Display Shift, S/C=1:Shift Display, S/C=0:Cursor shift, R/L=1:Shift to Right, R/L=1:Shift left, PD=0:Power Down Mode PD=1:Cancel Power Down Mode										DD RAM : Display data RAM CG RAM : Character generator RAM MK RAM : Icon display RAM AC : Address counter use for DD, CG and MK RAM	When FRQ is changed, the execute time is also changed.

Note : If the oscillation frequency is changed, the execution time is also changed.

NJU6475B

(3-1) Description of each instructions

(a) Maker Test

	RS	R/W	DB ₇	DB ₆	DB ₅	DB ₄	DB ₃	DB ₂	DB ₁	DB ₀
Code	0	0	0	0	0	0	0	0	0	0

(b) Clear Display

	RS	R/W	DB ₇	DB ₆	DB ₅	DB ₄	DB ₃	DB ₂	DB ₁	DB ₀
Code	0	0	0	0	0	0	0	0	0	1

Clear Display Instruction is executed when the code "1" is written into DB₀.

When this instruction is executed, the space code (20)_H is written into every DD RAM address, then the DD RAM (00)_H is set into address counter and I/D of entry mode is set as increment mode. If the cursor or blink are displayed, they are returned to the left end of the 1st line on the LCD panel.

In addition, S of entry mode is not changes and contents of MK RAM and CG RAM are also not changed.

Note : The character code (20)_H must be blank code in the user defined character pattern (Custom font).

(c) Return Home

	RS	R/W	DB ₇	DB ₆	DB ₅	DB ₄	DB ₃	DB ₂	DB ₁	DB ₀	
Code	0	0	0	0	0	0	0	0	1	*	*= Don't Care

Return Home instruction is executed when the code "1" is written into DB₁.

When this instruction is executed, the DD RAM address (00)_H is set into the address counter. Display is returned to its original position if shifted, the cursor or blink are returned to the left end of the 1st line on the LCD if the cursor or blink are operating. The DD RAM contents do not change.

(d) Entry Mode Set

	RS	R/W	DB ₇	DB ₆	DB ₅	DB ₄	DB ₃	DB ₂	DB ₁	DB ₀
Code	0	0	0	0	0	0	0	1	I/D	S

Entry Mode Set instruction which sets the cursor moving direction and display shift On/Off, is executed when the code "1" is written into DB₂ and codes of (I/D) and (S) are written into DB₁ (I/D) and DB₀ (S). (I/D) sets the address increment or decrement, and the (S) sets the entire display shift at the DD RAM writing.

I/D	F u n c t i o n
1	Address increment : The address of the DD RAM or CG RAM increment (+1) when the read/write operation, and the cursor or blink moves to the right.
0	Address decrement : The address of the DD RAM or CG RAM decrement (-1) when the read/write operation, and the cursor or blink moves to the left.
S	F u n c t i o n
1	Entire display shift. The shift direction is determined by I/D. : shift to left at I/D=1 and shift to the right at the I/D=0. The shift is operated only for the character, so that it looks as if the cursor stands still and display moves. The display does not shift when reading from DD RAM and writing/reading into/from CG RAM.
0	The display does not shift.

(e) Display ON/OFF Control

	RS	R/W	DB ₇	DB ₆	DB ₅	DB ₄	DB ₃	DB ₂	DB ₁	DB ₀
Code	0	0	0	0	0	0	1	D	C	B

Display ON/OFF control instruction which controls the whole display ON/OFF, the cursor ON/OFF and the cursor position character blink, is executed when the code "1" is written into DB₃ and codes of (D), (C) and (B) are written into DB₂ (D), DB₁ (C) and DB₀ (B), as shown below.

D	F u n c t i o n
1	Display On
0	Display Off. In this mode, the display data remains in the DD RAM so that it is retrieved immediately on the display when the D changes to 1.

C	F u n c t i o n
1	Cursor On. The cursor is displayed by 5 dots on the 8th line.
0	Cursor Off. Even if the display data write, the I/D etc does not change.

B	F u n c t i o n
1	The cursor position character is blinking. Blinking rate is 480ms at f _{osc} =180KHz. The cursor and the blink can be displayed simultaneously.
0	The character does not blink.

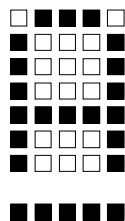

Character Font 5x7 Dots
(1) Cursor Display Example

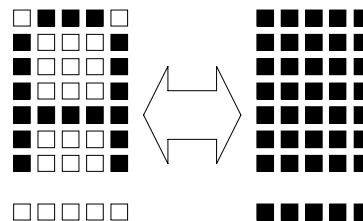

Alternating Display
(2) Brink Display Example

(f) Cursor Display Shift

	RS	R/W	DB ₇	DB ₆	DB ₅	DB ₄	DB ₃	DB ₂	DB ₁	DB ₀
Code	0	0	0	0	0	1	S/C	R/L	*	*

* = Don't Care

The cursor /display shift instruction shifts the cursor display to the right or left without writing or reading display data. This function is used to correct or search the display. The cursor moves to the 2nd line after the 12nd digit of the 1st line. Notice that 1st to 3rd line displays shift at the same time. When the displayed data are shifted repeatedly, each display moves in only same line. The 2nd and 3rd line display do not shift into the 1st and 2nd line.

The contents of address counter (AC) does not change by operation of only the display shift.

This instruction is executed when the code "1" is written into DB₄ and the codes of (S/C) and (R/L) are written into DB₃ (S/C) and DB₂ (R/L), as shown below.

S/C	R/L	F u n c t i o n
0	0	Shift the cursor position to the left ((AC) is decremented by 1).
0	1	Shift the cursor position to the right ((AC) is incremented by 1).
1	0	Shifts the entire display to the left and the cursor follows it.
1	1	shifts the entire display to the right and the cursor follows it.

NJU6475B

(g) Function Set

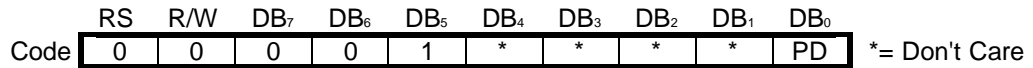

Function set instruction which sets the interface data length and power down is executed, when the code "1" is written into DB₅ and (PD) is written into DB₀, as shown below.

When the power down mode is set, the display turns off automatically. Afterward, when the power down mode is reset, the display is off continuously.

The display appears by the display on instruction.

PD	F u n c t i o n
1	Power down mode off (Normal operation)
0	Power down mode on (the display goes to off automatically.)

(h) Set Electronic Volume Register

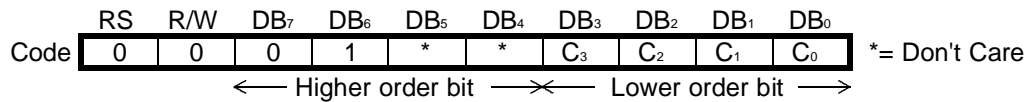

Contrast Control instruction which adjusts the contrast of LCD, is executed when the code "1" is written into DB₆ and the codes of C₀ to C₃ are written into DB₀ to DB₃ as shown below.

The contrast of LCD can be adjusted one of 16 voltage stage by setting 4 bit register.

Set the binary code "0000" when contrast control unused.

C ₃	C ₂	C ₁	C ₀		V _{LCD}
0	0	0	0		low
		⋮			
		⋮			
1	1	1	1		high

$V_{LCD} = V_{DD} - V_5$

(i) Set RAM Address

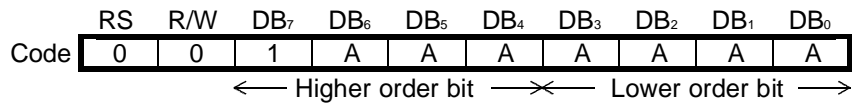

The RAM address set instruction is executed when the code "1" is written into DB₇ and the address is written into DB₆ to DB₀ as shown above.

The address data (DB₆ to DB₀) is written into the address counter (AC) by this instruction.

After this instruction execution, the data writing/reading is performed into/from the addressed RAM.

The RAM includes DD RAM, CG RAM and MK RAM and these RAMs are shared by addressed as shown below.

		RAM Address
DD RAM	1st Line	: (00) _H to (0B) _H
DD RAM	2nd Line	: (10) _H to (1B) _H
DD RAM	3rd Line	: (20) _H to (2B) _H
DD RAM	4th Line	: (30) _H to (3B) _H
CG RAM	4 Characters	: (40) _H to (5F) _H
MK RAM	128 Icons	: (60) _H to (7F) _H

(j) Write Data to CG, DD or MK RAM

-Write Data to DD RAM

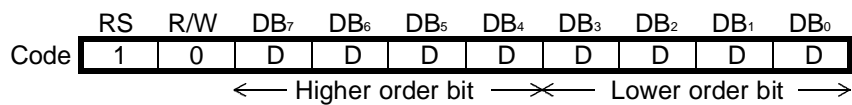

-Write Data to CG or MK RAM

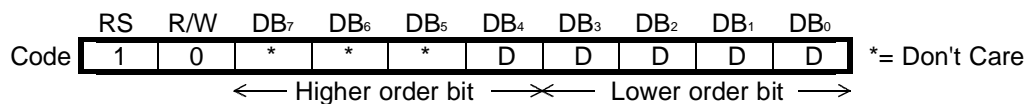

Write Data to RAM instruction is executed when the code "1" is written into (RS) and code "0" is written into (R/W).

By the execution of this instruction, the data is written into RAM. The selection of RAM is determined by the previous instruction.

After this instruction execution, the address increment (+1) or decrement (-1) is performed automatically according to the entry mode set.

NJU6475B

(3-2) Initialization using the internal reset circuit

When internal reset operates for initialization, the function set, Display ON/OFF Control and Entry Set instruction must be executed before the data input as shown below.

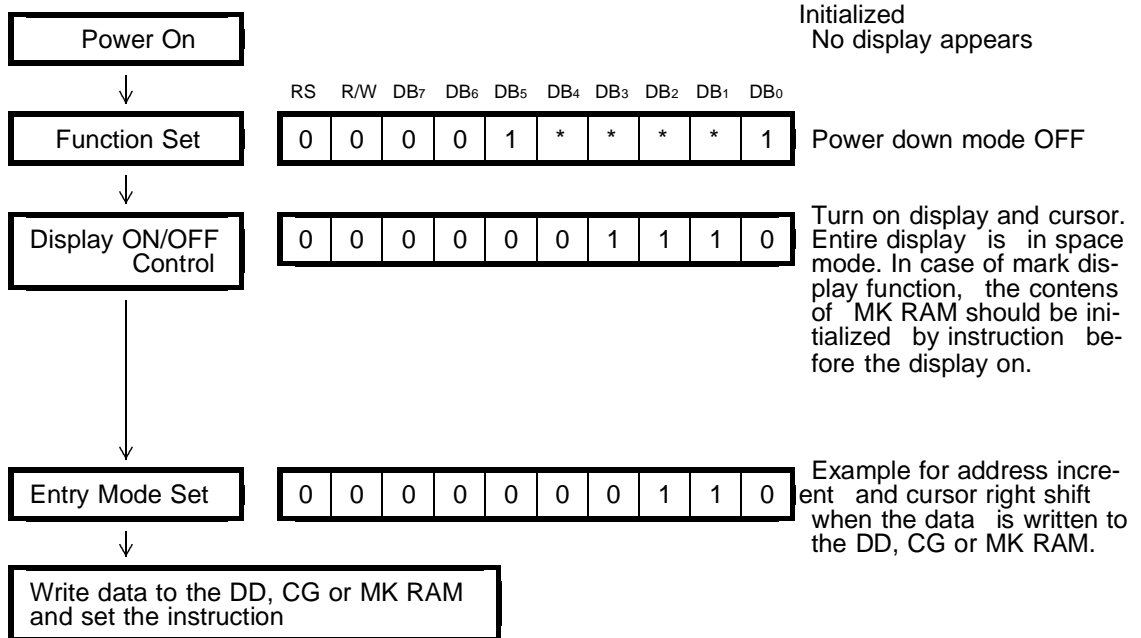

(3-3) Initialization by instruction

If the power supply conditions for the correct operation of the internal reset circuits are not met, the NJU6475B must be initialized by instruction.

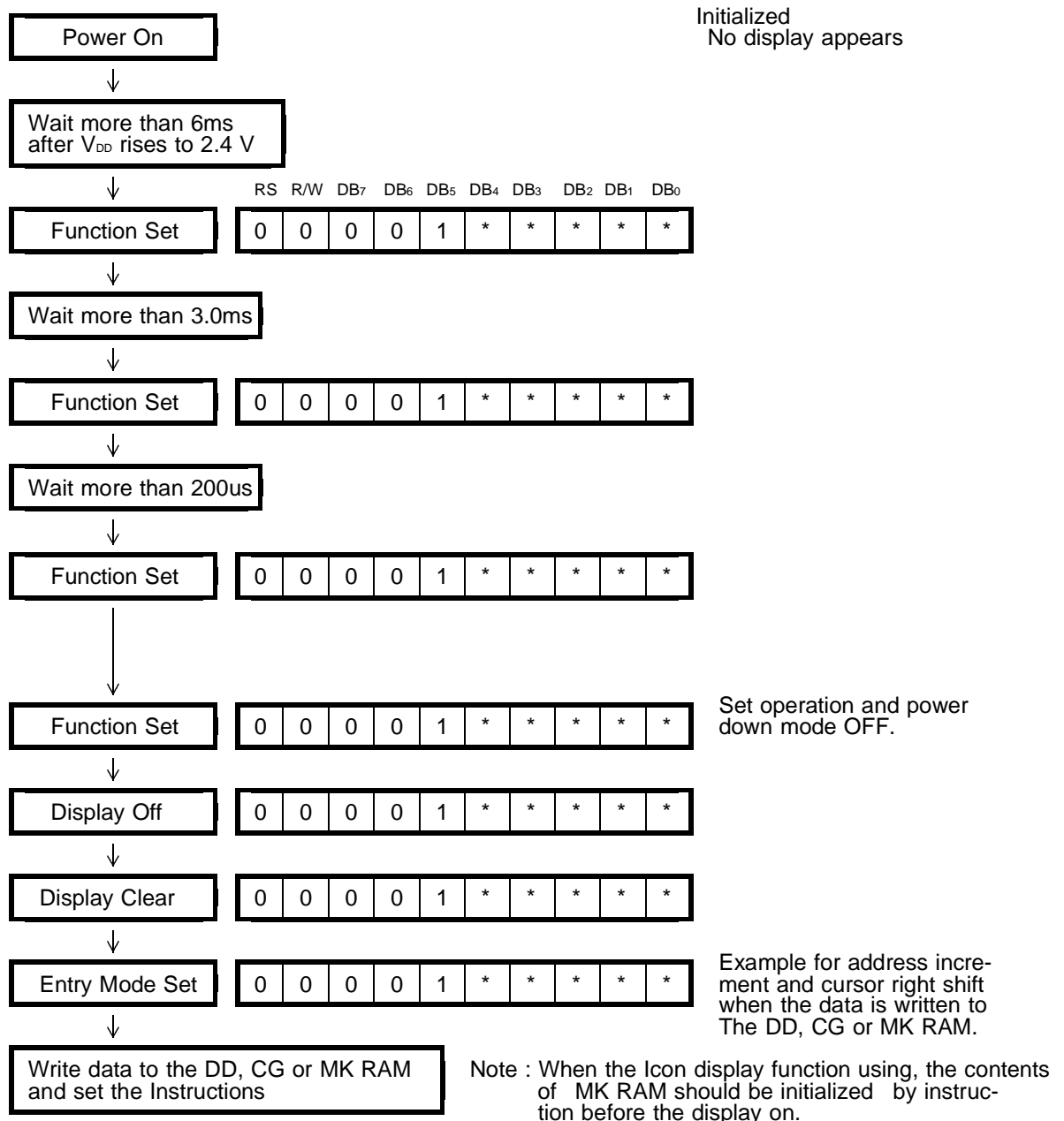

NJU6475B

(4) Power down Function

NJU6475B incorporates the power down mode to reduce the operating current.

The power down mode is set/reset by the function set instruction.

In the power down mode, all the character display and Icon display turn off and only static display operation is available.

The status of internal circuits at the power down mode is shown below.

-Main oscillator stops and sub oscillator for the static display starts the operation.

-Voltage converter, Key Scan, Voltage Regulator, Voltage follower (OP-AMP) are stopped.

-The contents of DD, CG, MK RAM are kept.

(5) LCD Display

(5-1) Power Supply for LCD Driving

NJU6475B incorporates voltage converter to generate the LCD driving voltage which is adjusted by the voltage regulator and the EVR.

(a) Voltage Converter

-Voltage Tripler

By connecting capacitor between $C1^+$ and $C1^-$, $C2^+$ and $C2^-$, V_{SS} and V_{SOUT} respectively, two times negative voltage of $V_{DD}-V_{SS}$ output from V_{SOUT} .

-Voltage Doubler

By connecting capacitor between $C2^+$ and $C2^-$, V_{SS} and V_{SOUT} respectively, and connecting the $C1^+$ terminal to $C2^+$ terminal, and $C1^-$ terminal being open, negative voltage of $V_{DD}-V_{SS}$ output from V_{SOUT} .

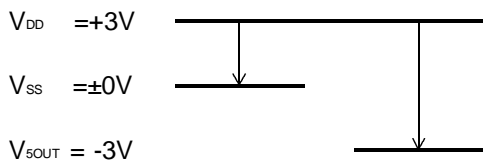

Voltage Doubler

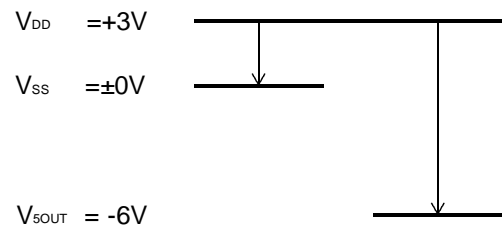

Voltage Tripler

(b) Voltage Regulator

Voltage Regulator incorporates a OP-AMP which is supplied V_{DD} and V_{SOUT} , and a reference voltage source (V_{REF}).

By setting the VR level by connecting R_a and R_b , the regulator which amplifies V_{REF} , outputs the LCD driving voltage to the V_{REG} terminal.

Therefore the LCD driving voltage can be output between V_{DD} and V_{REG} by setting.

$$V_{REG} = (1 + R_b / R_a) V_{REF} \text{ in condition, } V_{DD} = 0V, |V_{REG}| < |V_{SOUT}|$$

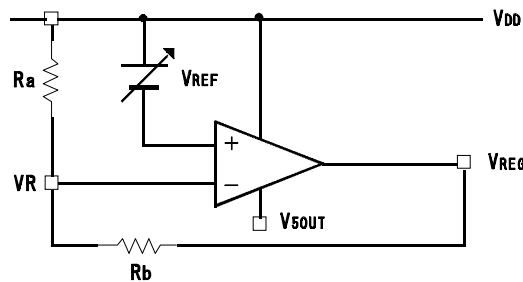

The EVR functions V_{REF} value adjustment from 1st step to 16th by a step when the 4 bit data write into the EVR register by the instruction.

Set the EVR register to $(00)_H$ when the EVR function is unused. Use variable resistances to external to the external resistances R_a , R_b and thermistor if need due to the voltage reference V_{REF} is changed by the lot and operating temperature.

Take care the noise input on the VR terminal because of it is designed with high impedance. Short wiring should be required to avoid the noise input, if necessary.

[The Voltage Reference V_{REF} Characteristics]

Supply Voltage : $V_{DD} = 0V, V_{SS} = -3V$

Temperature : 25 °C

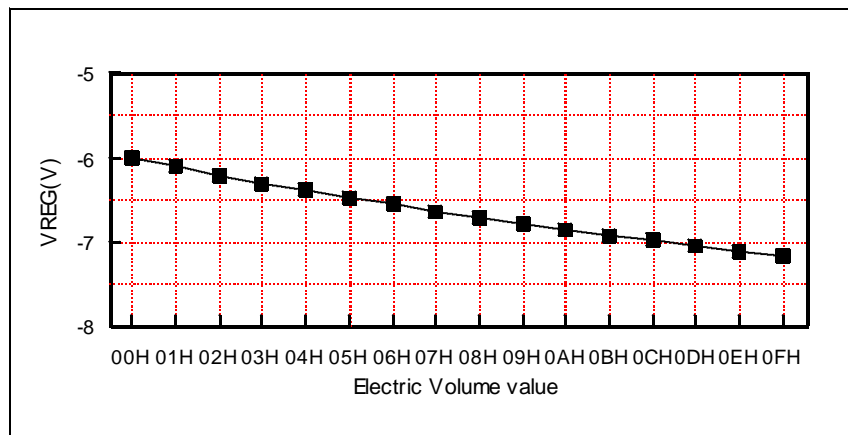

[The LCD Operating Voltage V_{REG} Characteristics]

Supply Voltage : $V_{DD} = 0V, V_{SS} = -3V,$
 External Resistances : $R_a = 180K\Omega, R_b = 820K\Omega$

Voltage Tripler Output : $V_{SOUT} = -9V$
 Temperature : 25 °C

Used Formulation : $V_{REG(XX)H} = (1 + 820k\Omega/180k\Omega) V_{REF(XX)H}$

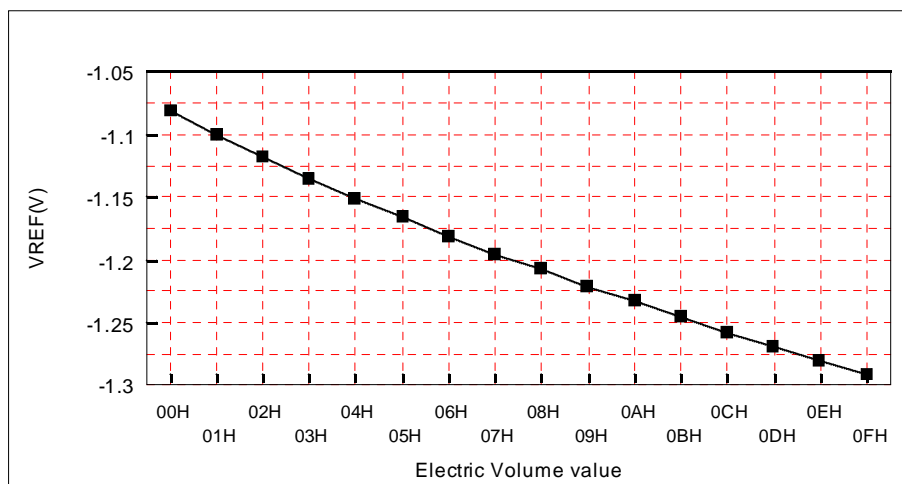

NJU6475B

(c) Bleeder Resistance

Each LCD driving voltage (V_1, V_2, V_3, V_4, V_5) is generated by the high impedance bleeder resistance buffered by voltage follower OP-AMP to get a enough display characteristics with low operating current. The bleeder resistance is set 1/7 bias suitable for 1/36 duty by $5M\Omega$ resistance in total.

The capacitor connected between V_5 and V_{DD} is needed for stabilizing V_5 . The determination of the each capacitance of C_1, C_2 and C_3 generating for LCD operating voltage is required to operate with the LCD panel actually.

The capacitance for the typical application is shown below:

LCD Driving Voltage vs Duty

Power	Duty Ratio	1/36
Supply	Bias	1/7
V_{LCD}		$V_{DD} - V_5$

V_{LCD} is the maximum amplitude for LCD driving voltage.

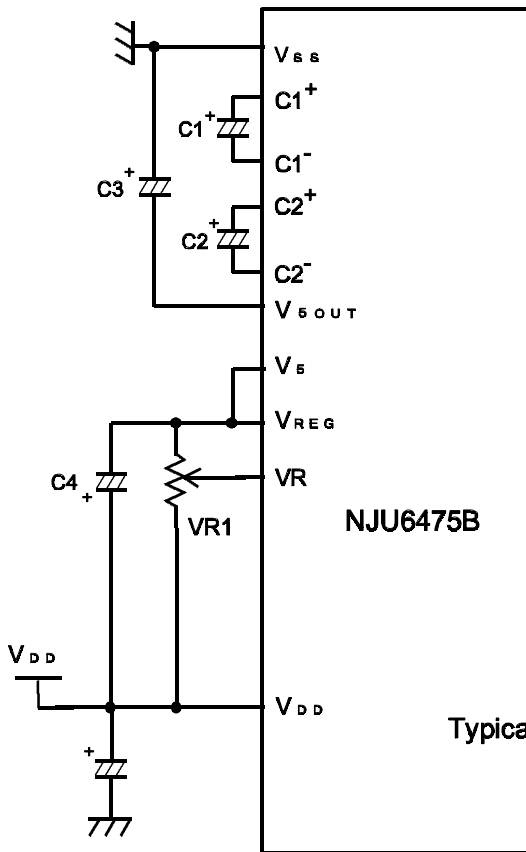

Typical capacitance :

$C_1, C_2, C_3, C_4 = 1.0 \sim 10 \mu F$

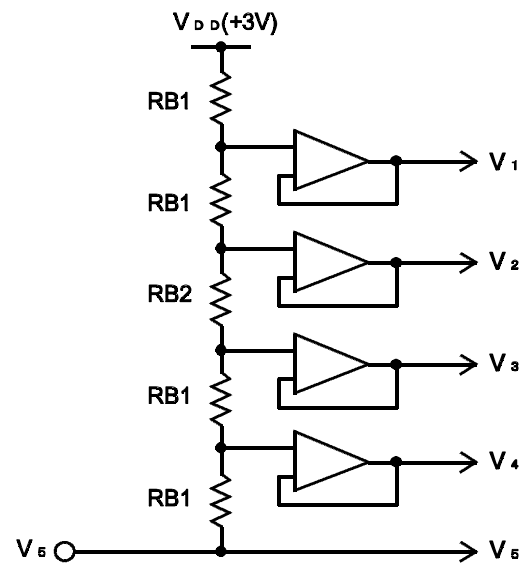

NJU6475B Bleeder Resistance

and Buffer Amplifire

RB1=714K Ω typ

RB2=2.14M Ω typ

RB=5.0M Ω typ

Typical application for LCD operating voltage generation

Note : Take care the noise into the VR terminal as designed with high impedance.
Short wiring or sealed wiring are required to avoid the noise, if necessary.

(5-2) Relation between oscillation frequency and LCD frame frequency

As the NJU6475B incorporates oscillation capacitor and resistor for CR oscillation, 180KHz oscillation is available without any external components. (1 Clock = 5.56us)

1/36 Duty

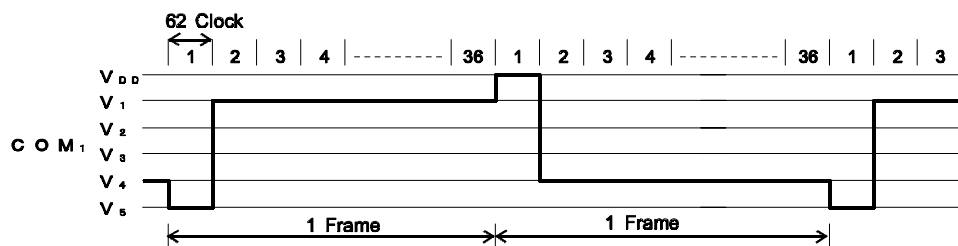

$$1 \text{ frame} = 5.56 \text{ (us)} \times 62 \times 36 = 12.4 \text{ (ms)}$$

$$\text{Frame frequency} = 1 / 12.4 \text{ (ms)} = 80.6 \text{ (Hz)}$$

NJU6475B

(6) Key Scan Circuit

(6-1) Key scan timing chart

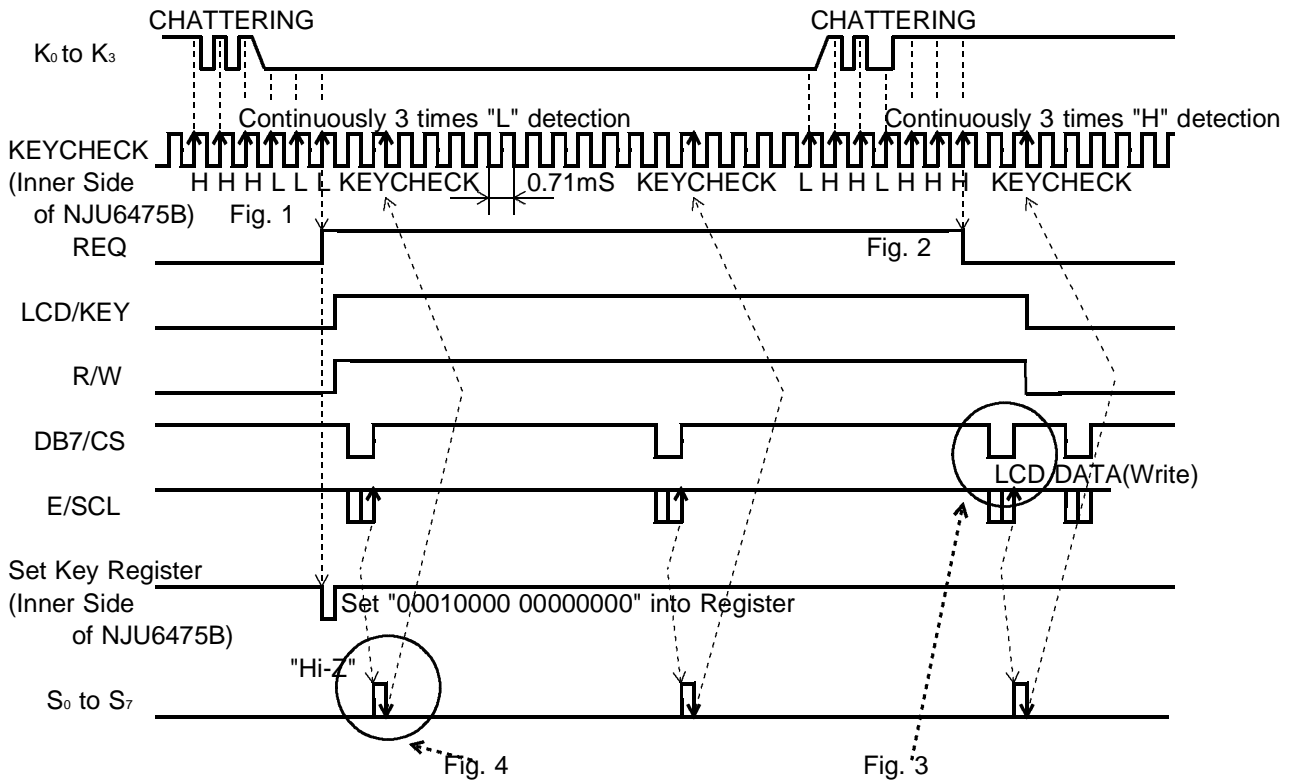

(6-2) Key Scan

1. KEYCHECK signal always operates to check the status of keys excepting for power down mode.
2. When Key signal (K₀ to K₃) 3 times detected continuously at rise up edge of KEYCHECK (inner side NJU6475), key Scan circuit performs output request signal (REQ terminal) rise to "H" and simultaneously key input information transmit to CPU. Its useful for anti-chattering. At the same time of REQ signal output, the key register status is "00010000 00000000" (Non Key Input) automatically. Key input terminal (K₀ to K₃) are "H" in normal, then turn to "L" when Key input.

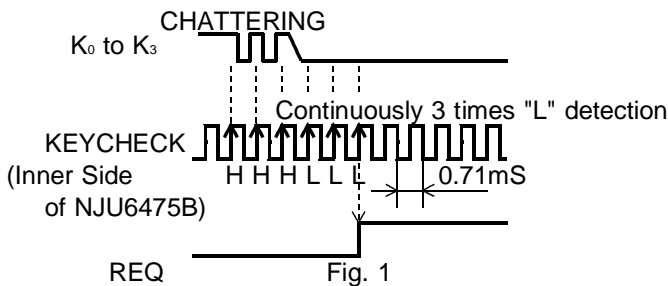

In case of request signal "H", When detects 3 times continuously key released status, request signal will be "L".

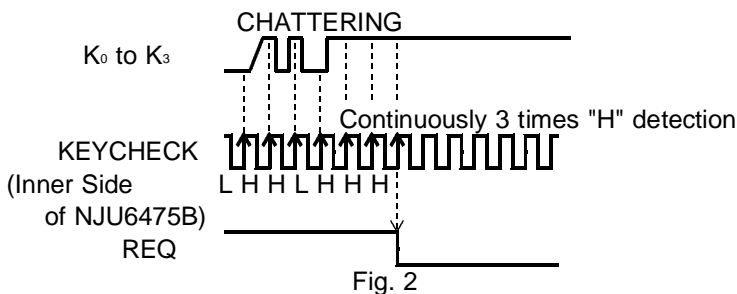

3. When the request signal is detected, CPU should LCD / KEY to "H" and read out key data by instruction. 16-bit key data synchronizing to "SCL" (SCL terminal) is read out to CPU.
 (1st time output key data was fixed as "00010000 00000000")
 keyscan operation start from the next rising edge of SCL after the end of key data read out operation.

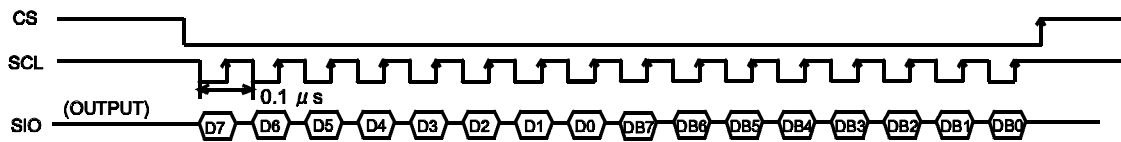
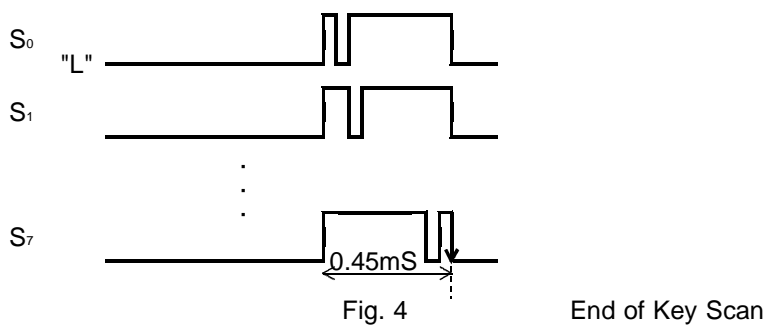

Fig. 3

4. The key data are gotten from 4 terminals (K_0 to K_3) at each timing of key scan signals (S_0 to S_7).
 The detected data are up dating anytime and stores to key register.



- Key scan timing : 0.45ms (fosc = 180KHz, MAX =0.64ms)
- Pulth width : 45us (fosc = 180KHz, MAX =64us)

NJU6475B

(6-3) Key scanning timing

Key status is gotten at 3/4 port timing of t_{kp} during "L" period of S_0 to S_7 .

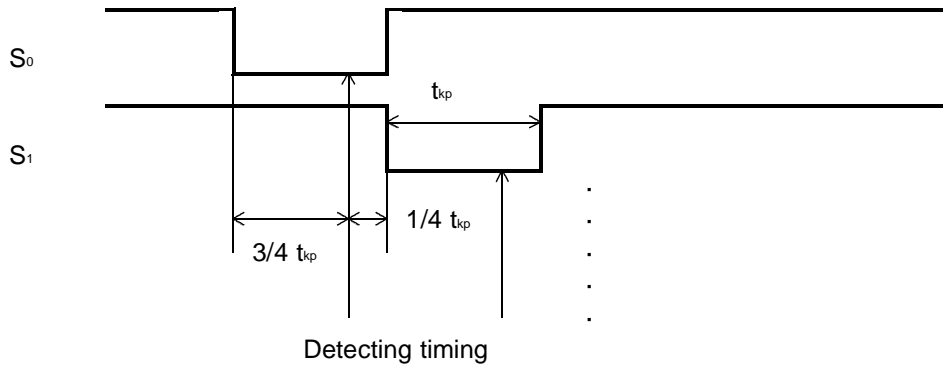

(6-4) The format of detection

1st Byte

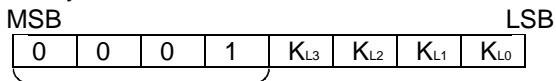

Fix

K_{L3} to K_{L0} : Corresponds to K_3 to K_0

2nd Byte

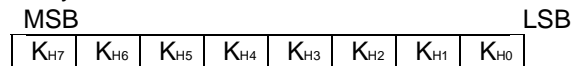

K_{H7} to K_{H0} : Corresponds to S_7 to S_0

(For Example)

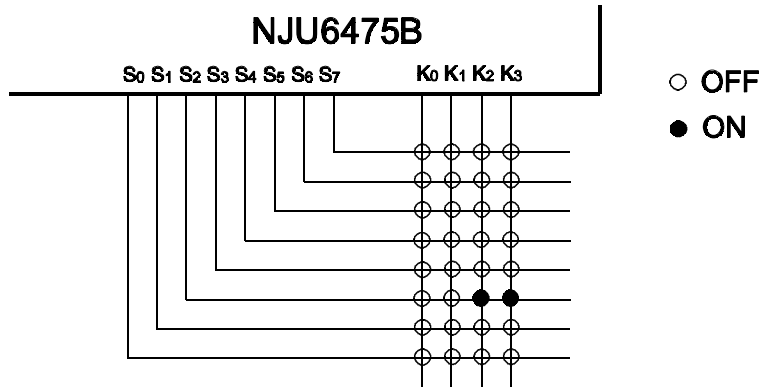

1st Byte

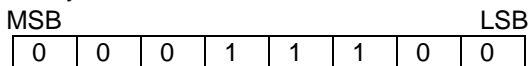

2nd Byte

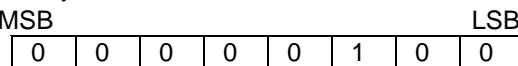

(6-5) Key roll over input

NJU6475B can be accepted the key roll over input.
In case of key roll over input, the output results are shown below;

-Connecting same S_x signal line at multiple key push.

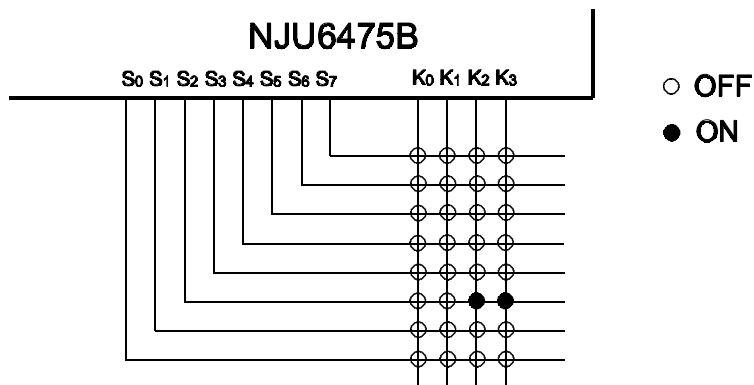

When key-in shown above case, the data contents are "00011100" "00000100".

-The case of connecting different S_x signal line at multiple key push (1)

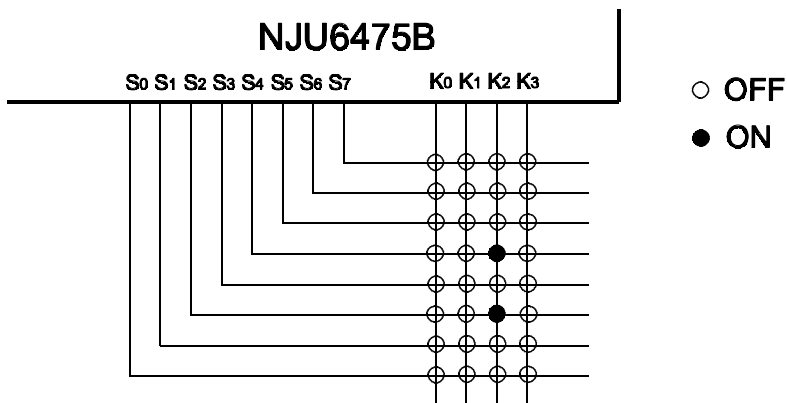

When key-in shown above case, the data contents are "00010100" "00010100".

NJU6475B

-The case of connecting different S_x signal line at multiple key push (2)

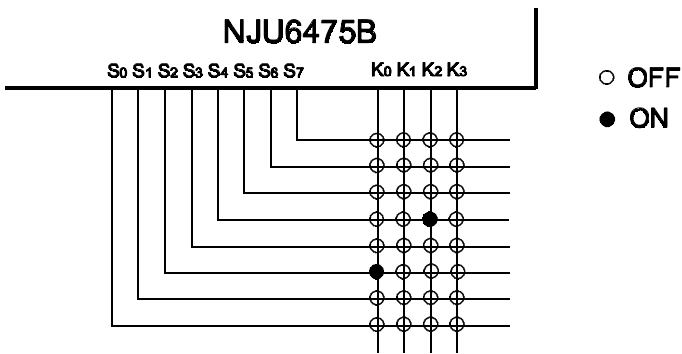

When key-in like as shown above, the data contents are "00010101" "00010100".
In this case, the result will be same, at each key-in shown below.

[Case 1]

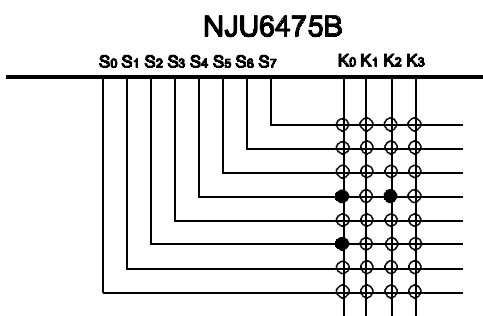

[Case 2]

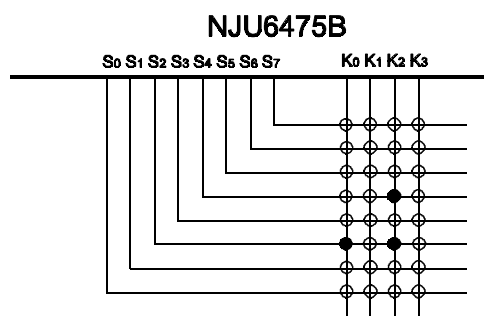

[Case 3]

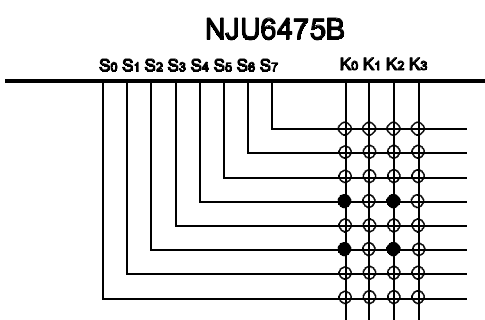

[Case 4]

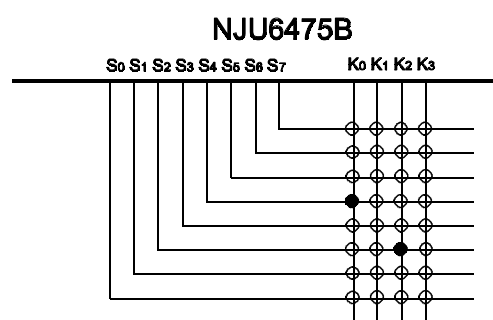

[Case 5]

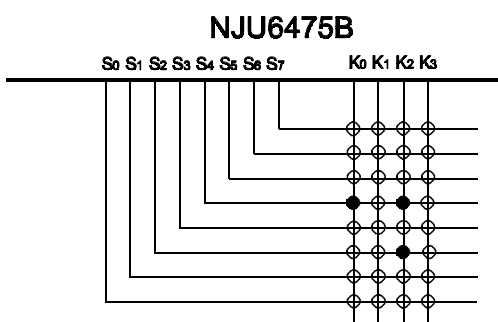

[Case 6]

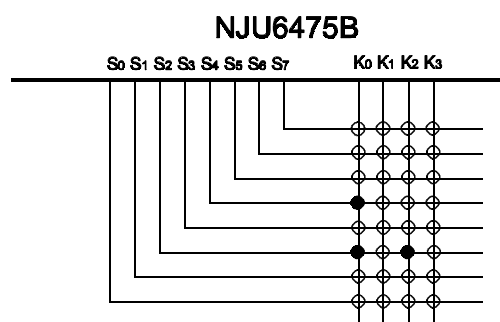

(6-6) The inner composition of Key Scan circuit

The inner composition of key scan circuit shown below :

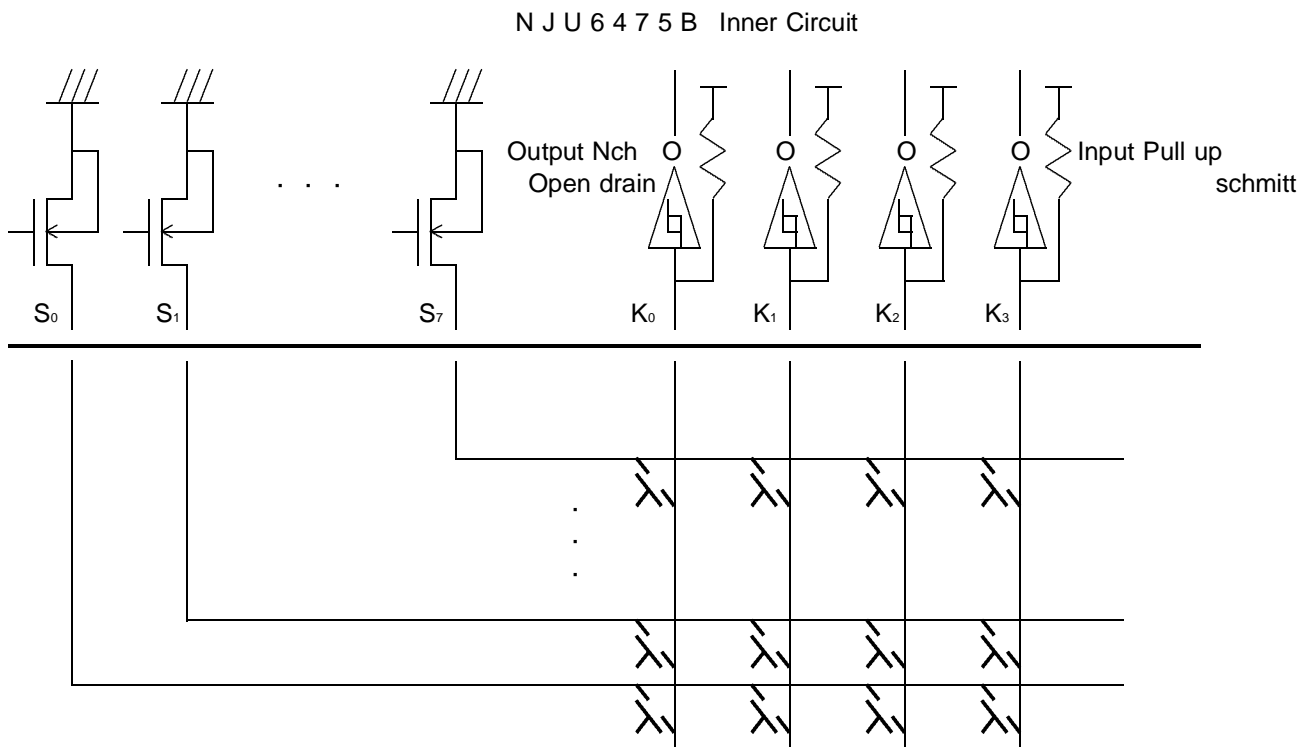

-In case of non input the key each terminal status shown below:

S₀ to S₇ : The status of Nch FET output side is ON, output result is "L".

K₀ to K₃ : The status is "H" by pull-up resistance.

-When any key key-in, K_x of key-in side turn to "L" and it can confirms.

-Input terminal (K₀ to K₃) are composed by schmitt inverter input method.

NJU6475B

(7) Interface with MPU

Interface circuit of NJU6475B can be connected to serial by turn to "L" P/S terminal on shown below serial data timing. And DB₀ to DB₅ can be use to output port.

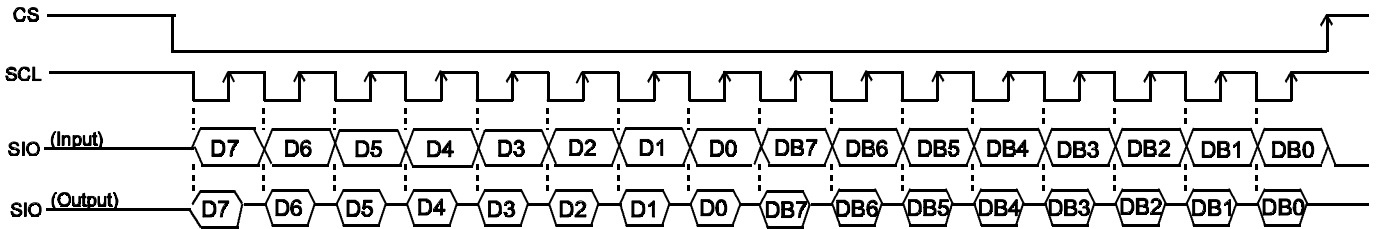

Notes : RS, R/W, LCD/KEY requires setting before CS fall down.
RS is unrelated to read out of key data and writing of port data.

Serial interface circuit is in operation at CS is "L".
When SCL rises, input data was lead, and rises CS case loading input data.
When the input data was less than 16 bits, input data will be invalid at rises CS. And so on equal or over than 16 bits case, rear side total 16 bits are effectiveness. The input data should be total 16 bits.
The data of read/write are composed MSB first.

-Data format

The data formatted by 2 byte form at read/write.

When writing data consists LCD data and port data.

The using data in write mode means one of key data.

In write mode of data format, 1st byte means recognition data of LCD data and Port data.

In "0110 0000" (fixed) selects LCD data, in "0110 0001" (fixed) selects Port data.

The data of 2nd byte consists each data contents.

When the 1st byte of MSB 4 bit data are not "0110", in this case the input data will be invalid.

				*	D ₇	D ₆	D ₅	D ₄	D ₃	D ₂	D ₁	D ₀	DB ₇	DB ₆	DB ₅	DB ₄	DB ₃	DB ₂	DB ₁	DB ₀	*	
	LCD/ KEY	RS	R/W		1st Byte								2nd Byte									
LCD Data	0	0	0		Higher Selected Bit (0110)				Lower Selected Bit (0000)				LCD Data (Instruction)								Instruction Execution Time	
LCD Data	0	1	0		Higher Selected Bit (0110)				Lower Selected Bit (0000)				LCD Data (RAM Data)								Instruction Execution Time	
PORT Data	0	*	0		Higher Selected Bit (0110)				Lower Selected Bit (0001)				Output Port (Set "L"=0,"H"=1)								Instruction Execution Time	
													*	*	DB ₅	DB ₄	DB ₃	DB ₂	DB ₁	DB ₀		
KEY Data	1	*	1		Selected Bit (0001)				Key Data 1				Key Data 2									
					X	X	X	X	X	X	X	X	X	X	X	X	X	X	X	X	X	
					L	L	L	L	L	L	L	L	H	H	H	H	H	H	H	H	H	
					3	2	1	0	7	6	5	4	3	2	1	0						

* : Invalid Data

Notes : The instruction requires execution time after transmit 16 bit data. After transmit data can not transmit continuously

NJU6475B

■ MAXIMUM ABSOLUTE RATINGS

PARAMETER	SYMBOL	RATINGS	UNIT	NOTE
Supply Voltage (1)	V_{DD}	- 0.3 ~ + 7.0	V	
Input Voltage	V_i	- 0.3 ~ $V_{DD} + 0.3$	V	
Operating Temperature	T_{opr}	- 30 ~ + 80	°C	
Storage Temperature	T_{stg}	- 55 ~ + 125	°C	

Note-1 : If the LSI are used on condition above the absolute maximum ratings, the LSI may be destroyed. Using the LSI within electrical characteristics is strongly recommended for normal operation. Use beyond the electric characteristics conditions will cause malfunction and poor reliability.

Note-2 : Decoupling capacitor should be connected between V_{DD} and V_{SS} due to the stabilized operation for the voltage converter.

Note-3 : All voltage value are specified as $V_{SS} = 0V$.

The relation : $V_{DD} > V_{SS}$, $V_{DD} > V_{SS} \geq V_{5out}$, $V_{SS} = 0V$ must be maintained.

■ ELECTRICAL CHARACTERISTICS (V_{DD} = 2.4 ~ 3.6V, Ta = -20 ~ +75 °C)

P A R A M E T E R		SYMBOL	C O N D I T I O N S		MIN.	TYP.	MAX.	UNIT	NOTE
Input Voltage 1		V _{IH1}	(OSC1, Except terminals K ₀ ~ K ₃)		0.8V _{DD}	-	V _{DD}	V	4
		V _{IL1}	(OSC1, Except terminals K ₀ ~ K ₃)		V _{SS}	-	0.2V _{DD}	V	4
Input Voltage 2		V _{IH2}	(Application to terminals K ₀ ~ K ₃)		0.8V _{DD}	-	V _{DD}	V	4
		V _{IL2}	(Application to terminals K ₀ ~ K ₃)		V _{SS}	-	0.2V _{DD}	V	4
Input Voltage 3		V _{IH3}	(Applicate to terminal OSC1)		V _{DD} -0.5	-	V _{DD}	V	4
		V _{IL3}	(Applicate to terminal OSC1)		V _{SS}	-	0.5	V	4
Output Voltage 1		V _{OH1}	-I _{OH} = 0.205mA, V _{DD} = 3.0V		2.0	-	-	V	5
		V _{OL1}	I _{OL} = 1.6mA, V _{DD} = 3.0V		-	-	0.5	V	5
Output Voltage (S ₀ ~ S ₇)		V _{OL2}	I _{OL} = 300uA		-	-	0.6	V	
Driver ON-resist (COM)		R _{COM1}	±I _d = 1uA (All COM Terminal) V _O = V _{DD} , V ₅		-	-	20	kΩ	8
Driver ON-resist (SEG)		R _{SEG1}	±I _d = 1uA (All SEG Terminal) V _O = V _{DD} , V ₅		-	-	30	kΩ	8
Driver Output-resist (COM)		R _{COM2}	±I _d = 1uA (All COM Terminal) V _O = V ₁ , V ₄		-	-	40	kΩ	8
Driver Output-resist (SEG)		R _{SEG2}	±I _d = 1uA (All SEG Terminal) V _O = V ₂ , V ₃		-	-	50	kΩ	8
Driver current		IV ₁	V ₁ Sink Current		-	-	-12.3	uA	
		IV ₄	V ₄ Source Current		16.8	-	-	uA	
Input Leak Current		ILI	V _{in} = 0 ~ V _{DD}		-1	-	1	uA	6
Pull-up MOS Current		-I _p	V _{DD} = 3V (ALL DB, K ₀ ~ K ₃ terminal)		10	25	50	uA	
Operating Current		I _{DD1}	f _{OSC} = Internal OSC on Display V _{DD} = 3V, On display, V ₅ = -5V			320	380	uA	7
		I _{DD2}	f _{OSC} = Internal OSC on Display V _{DD} = 3V, On access, t _{CYCE} = 5uS			-	640	uA	7
voltage converter Part	Output Voltage	V _{SOUT}	V _{DD} = 3V Ta = 25°C	I _{OUT} 3 Times = 100uA	-4.6	-4.8		V	
	Voltage Efficiency	V _{ef}	R _L = ∞	3 Times	90.0	95.0		%	
LCD Drive Voltage		V ₁	Ta = 25°C		2.44	2.57	2.70	V	
		V ₂	V _{DD} = 3V		2.01	2.14	2.27		
		V ₃	V ₅ = 0V		0.73	0.86	0.99		
		V ₄	Measured at COM/SEG terminal		0.30	0.43	0.56		
Bleeder Resistance R _B (V _{DD} - V ₅)/I _B I _B :Bleeder Resistance Cur. R _B : 5 Bleeder Resist		R _B	V _{DD} - V ₅ = 3V			5.0		MΩ	
reg.	Output Voltage	V _{REG}	R _L = ∞, R _{RV} =1MΩ, V _{SOUT} = -10.8V		V _{DD} -10.8	-	V _{DD} -1.8	V	
	Operating voltage	V _{SOUT}	V _{DD} Reference		V _{DD} -11	-	V _{DD} -3.6		
	Reference Voltage	V _{REF}	V _{DD} Reference, Ta=25°C		V _{DD} -0.75	V _{DD} -1.05	V _{DD} -1.35		
Clock Oscillation Freq.		f _{OSC}	V _{DD} = 3V, Ta=25°C		125	180	235	kHz	
LCD Driving Voltage		V _{LCD}	V _{SOUT} Terminal, V _{DD} = 3V		V _{DD} -3	-	V _{DD} -13.5	V	9

NJU6475B

Note-4 : Input/Output structure except LCD display are as shown below.

-Input terminal structure

(without pull-up MOS)
 Applicated terminals : E/SCL, RS,
 R/W, P/S, SEL, RESET, LCD/KEY

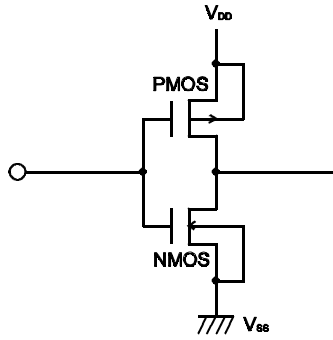

(Pull-up with MOS, schmitt)
 K₀ ~ K₃

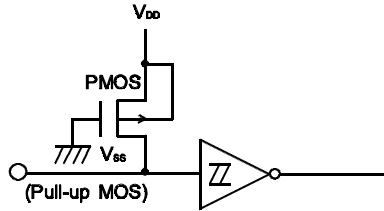

(Pull down MOS)
 TEST

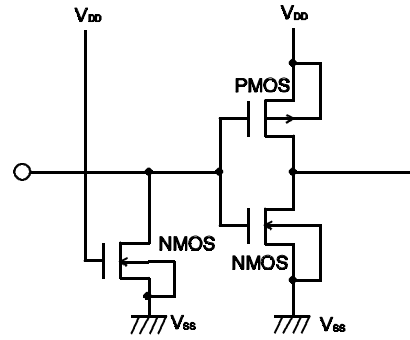

-Input terminals structure

Applicated terminal : OSC1

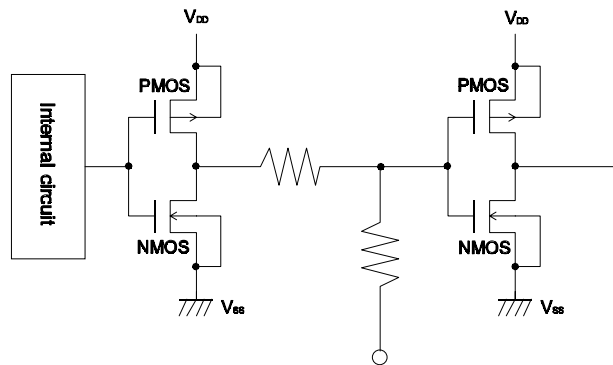

-Common terminals

Input/Output structure.

Applicated terminal
 : DB₇ to DB₀

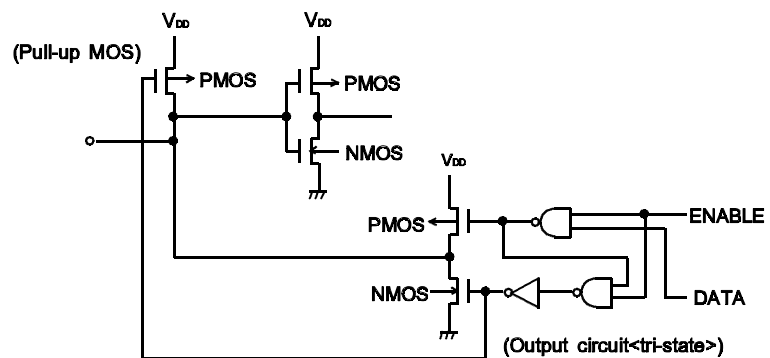

Note-5 : Apply to the output and Input/Output Terminals.

Note-6 : Except current of pull-up MOS and output drive MOS.

Note-7 : Except Input/Output part current but including the current on bleeder resistance.

If the input level is medium, current consumption will increase due to penetration current. therefore, the input level must be fixed to "H" or "L".

-Operating Current Measurement Circuit

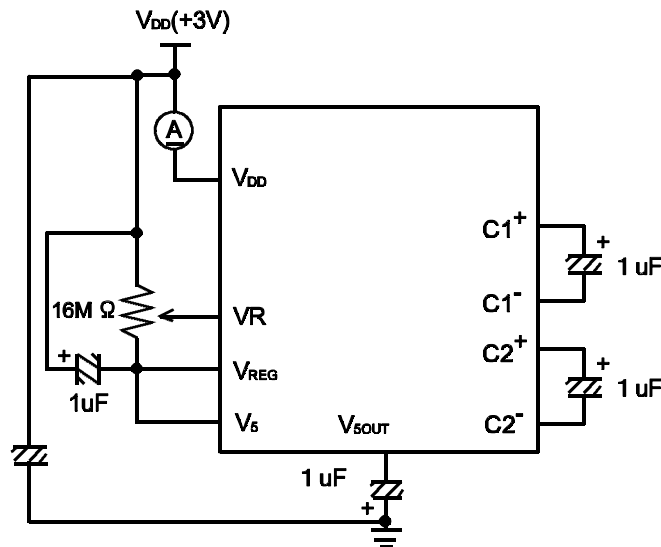

Note-8 : R_{com} and R_{seg} are the resistance values between power supply terminals (V_{DD}, V_{5OUT}) and each common terminal (Com₁ to Com₃₂ / COMM₁ to COMM₄) and Supply voltage (V_{DD}, V_{5OUT}) and each segment terminal (SEG₆₀ / SEGM₁ to SEGM₂) respectively, and measured when the current I_d is flown on every common and segment terminals at same time.

Note-9 : Apply to the voltage from each COM and SEG are less than ±0.15V against the LCD driving contrast voltage (V_{DD}, V_{5OUT}) at no load condition.

Voltage converter characteristics

measurement circuit

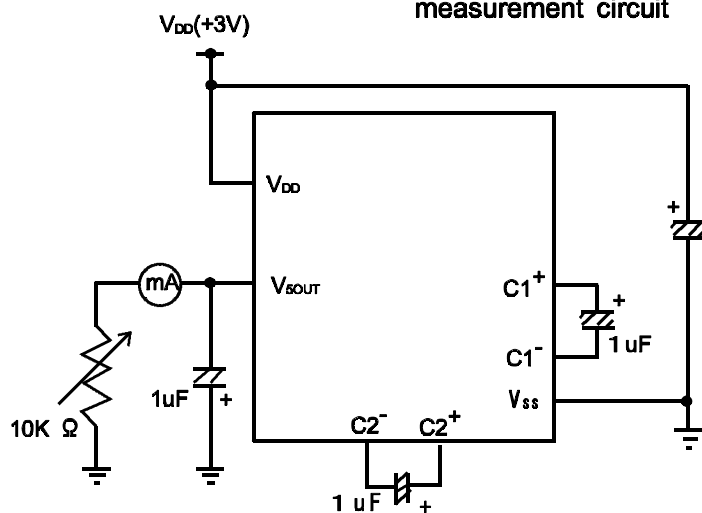

Voltage converting clock frequency = 1.1 KHz (TYP)

Internal bleeder resistance

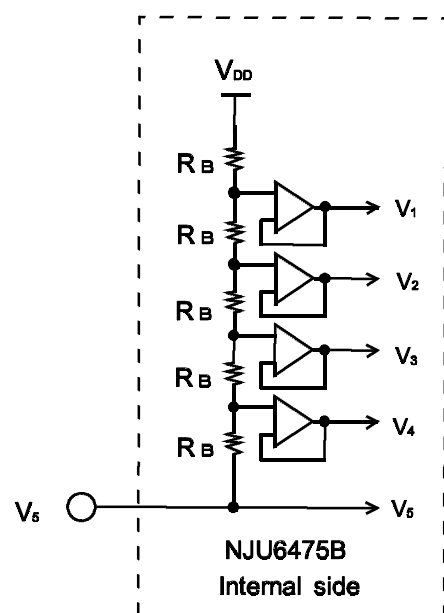

NJU6475B

■ BUS TIMING CHARACTERISTICS

-Serial Interface sequence

($V_{DD} = 2.4 \sim 3.6V$, $V_{SS} = 0V$, $T_a = -20 \sim +75^\circ C$)

PARAMETER		SYMBOL	MIN.	MAX.	CONDITION	UNIT
Serial clock cycle time		t_{CYCE}	1	-	Fig. 1	μS
Serial clock width	"High" level	t_{SCH}	300	-	Fig. 1	nS
	"Low" level	t_{SCL}	700	-	Fig. 1	nS
Serial clock rise and fall down time		t_{scr} , t_{scf}	-	20	Fig. 1	nS
Chip select pulse width		PW_{CS}	500	-	Fig. 1	nS
Chip select set up time		t_{CSU}	200	-	Fig. 1	nS
Chip select hold time		t_{CH}	300	-	Fig. 1	nS
Chip select rise and fall time		t_{csr} , t_{csf}	-	20	Fig. 1	nS
Set up time	RS, R/W, LCD/KEY-CS	t_{AS}	200	-	Fig. 1	nS
Address hold time		t_{AH}	200	-	Fig. 1	nS
Serial input data set up time		t_{SISU}	200	-	Fig. 1	nS
Serial input data hold time		t_{SIH}	200	-	Fig. 1	nS
Serial output data delay time		t_{SOD}	-	700	Fig. 1	nS
Serial output data hold time		t_{SOH}	200	-	Fig. 1	nS

Serial Interface

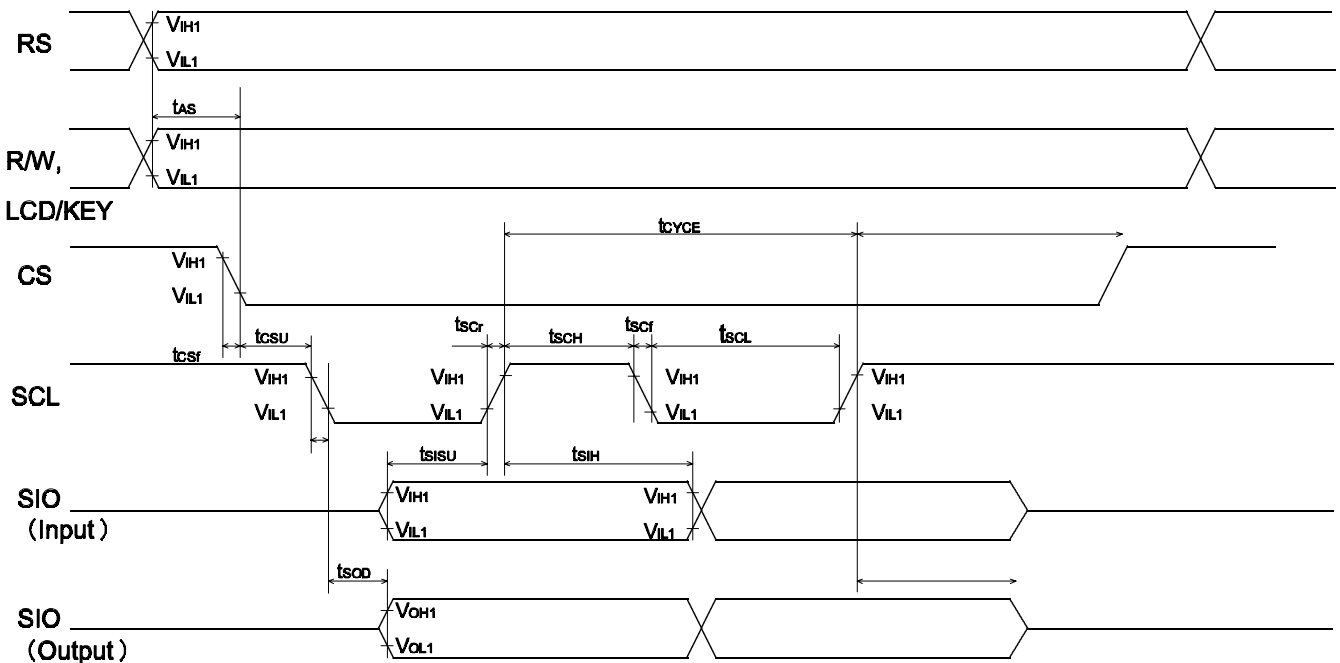

Fig. 3 Serial Interface Sequence Characteristics

-I/O Part sequence

PARAMETER	SYMBOL	MIN.	MAX.	CONDITON	UNIT
Port set time	t_{PS}	-	500	Fig. 2	μS

-The load of DB_0 to DB_7 is $CL = 100 \text{ pF}$

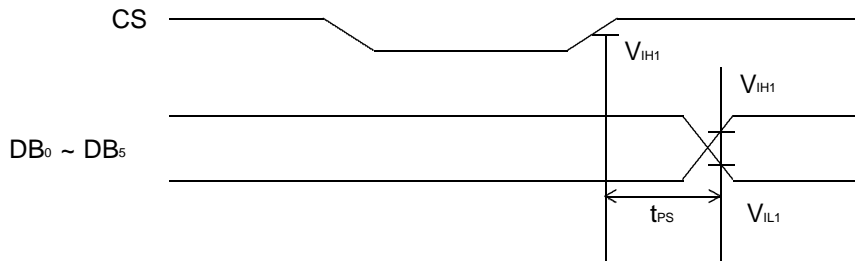
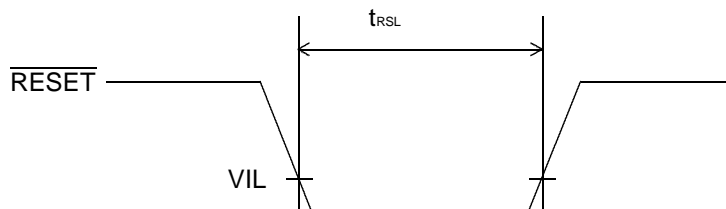

Fig. 2 I/O Port Sequence (Serial Interface)

-The input conditions of using hardware reset circuit.

Input Timing



PARAMETER	SYMBOL	CONDITION	MIN.	TYP.	MAX.	UNIT
Reset Input RAW level width	t_{RSL}	-	1.2	-	-	ms

-The power supply conditions of using power on reset circuit.

($T_a = -20 \sim +75^\circ C$)

PARAMETER	SYMBOL	CONDITION	MIN.	TYP.	MAX.	UNIT
The power supply rise time	t_{rDD}	-	0.1	-	5	ms
The power OFF time	t_{OFF}	-	1	-	-	ms

Since the internal initialization circuits will not operate normally unless the above conditions are met, in such a case of initialized by instruction. (Refer to initialization by the instruction)

t_{OFF} specifies the power off time in a short period off or cyclical on/off.

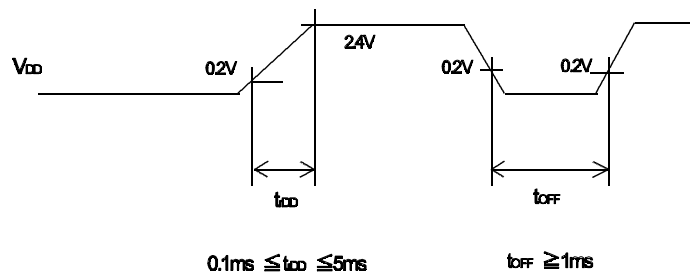

* t_{OFF} specifies the power off time in a short period off or cyclical ON/OFF.

NJU6475B

-Key Scan Sequence

PARAMETER	SYMBOL	MIN.	TYP.	MAX.	CONDITION	UNIT
E/SCL-S ₀ to S ₇ Delay time	t _{KDS}	-	66.7	300	Fig. 3	uS
Key scan pulse width "H","L" level	t _{KP}	-	44.4	48	Fig. 3	uS
Key scan time	t _{KS}	-	0.36	0.38	Fig. 3	mS
REQ output delay time	t _{KDR}	-	-	1.0	Fig. 3	uS
Key in check signal frequency	t _{KF}	0.98	1.41	1.84	Fig. 3	KHz

-The load of K₀ to K₃ is CL = 20 pF

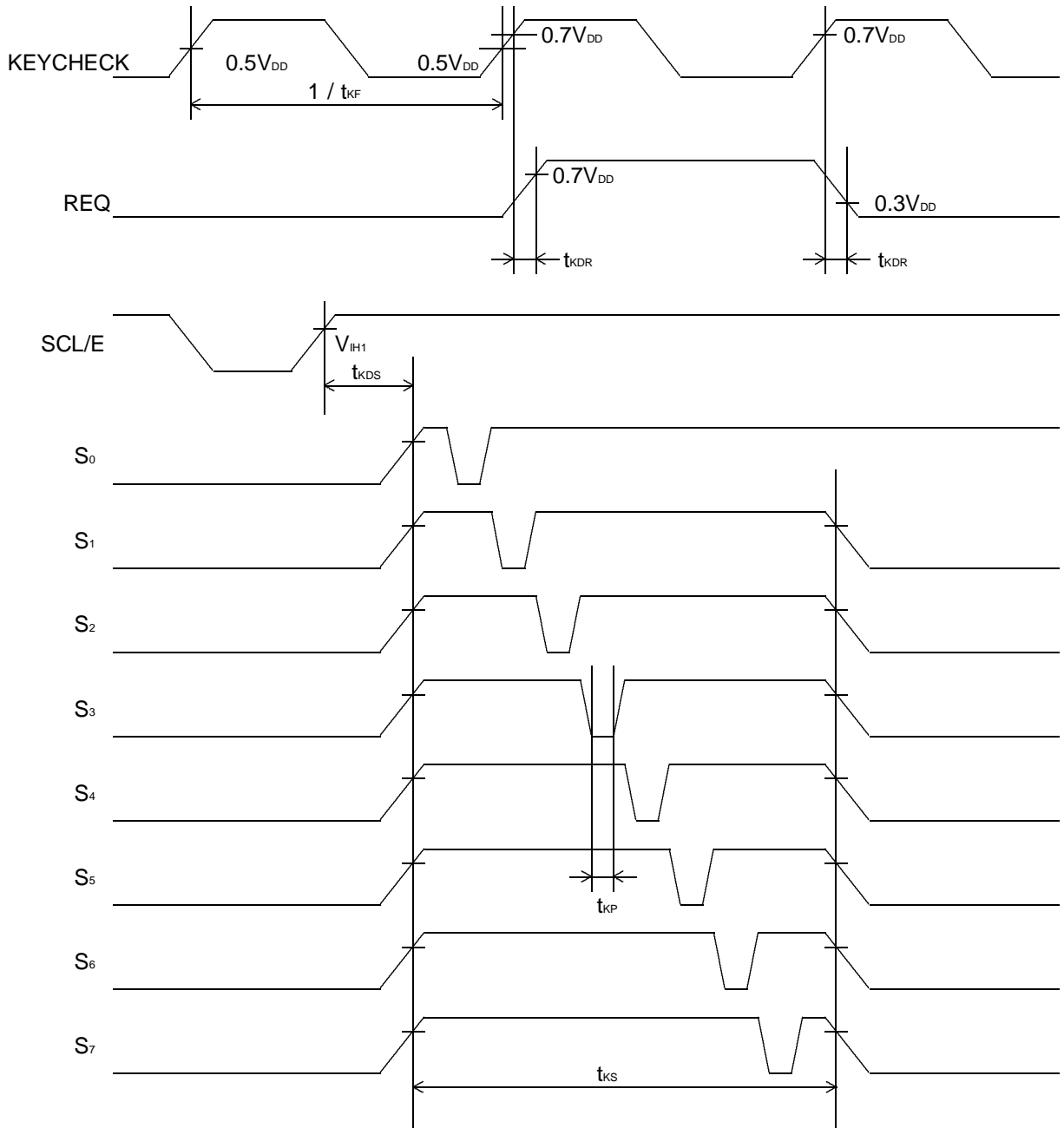

Fig. 3 Key scan sequence

-External clock input

P A R A M E T E R	SYMBOL	MIN.	MAX.	CONDITION	UNIT
External clock operating frequency	f_{CP}	125	235	Fig. 4	KHz
External clock duty	Duty	45	55	Fig. 4	%
External clock rise time	t_{CPr}	-	0.2	Fig. 4	uS
External clock fall time	t_{CPf}	-	0.2	Fig. 4	uS

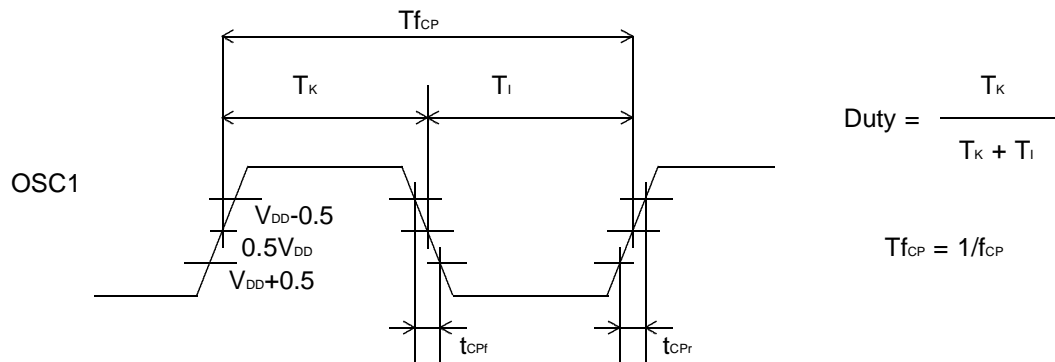
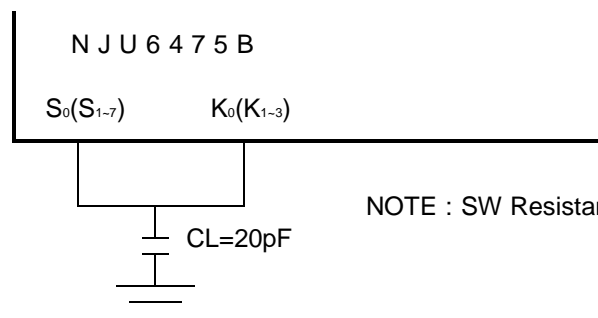

Fig.4 External clock input

-The key scan circuit timing characteristics measurement circuit



NOTE : SW Resistance is 0Ω
(measurement : only pattern wires)

NJU6475B

■ LCD DRIVING WAVE FORM

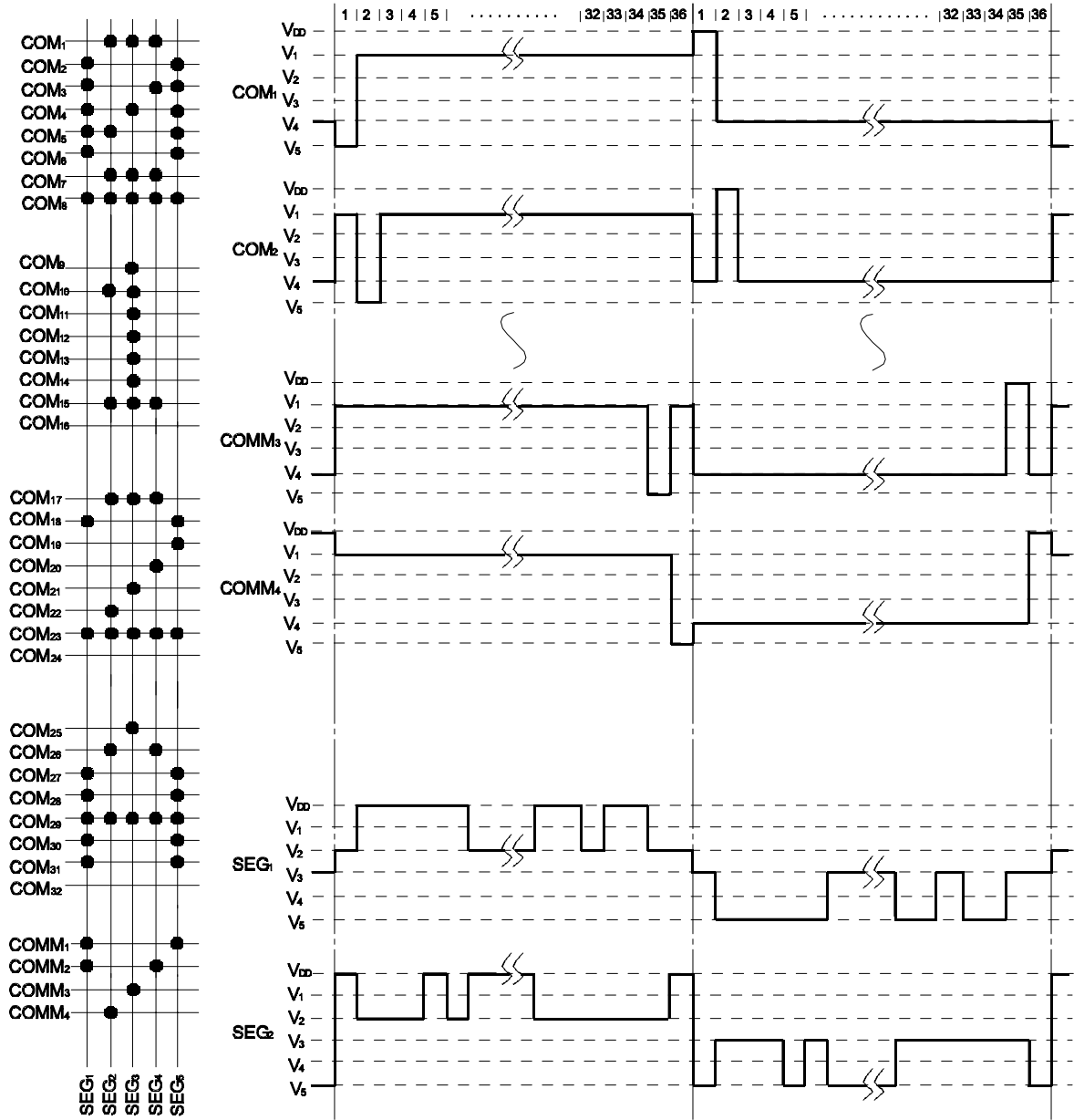

N J U 6 4 7 5 B
LCD Driving Wave Form 1/36 Duty

■ APPLICATION CIRCUIT (1)

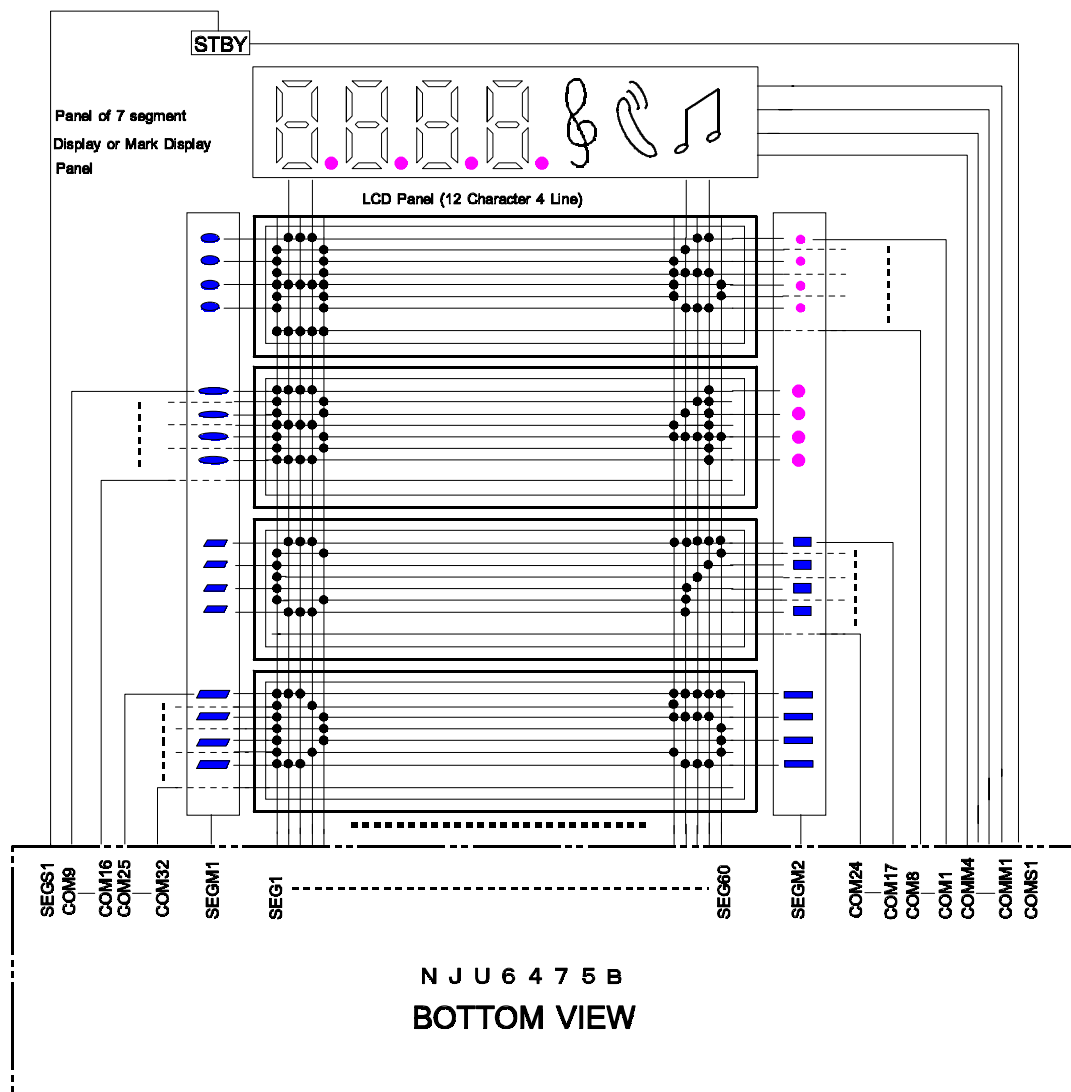

12-Character 4-Line
(Terminal description, Mode A)

NJU6475B

APPLICATION CIRCUIT (2)

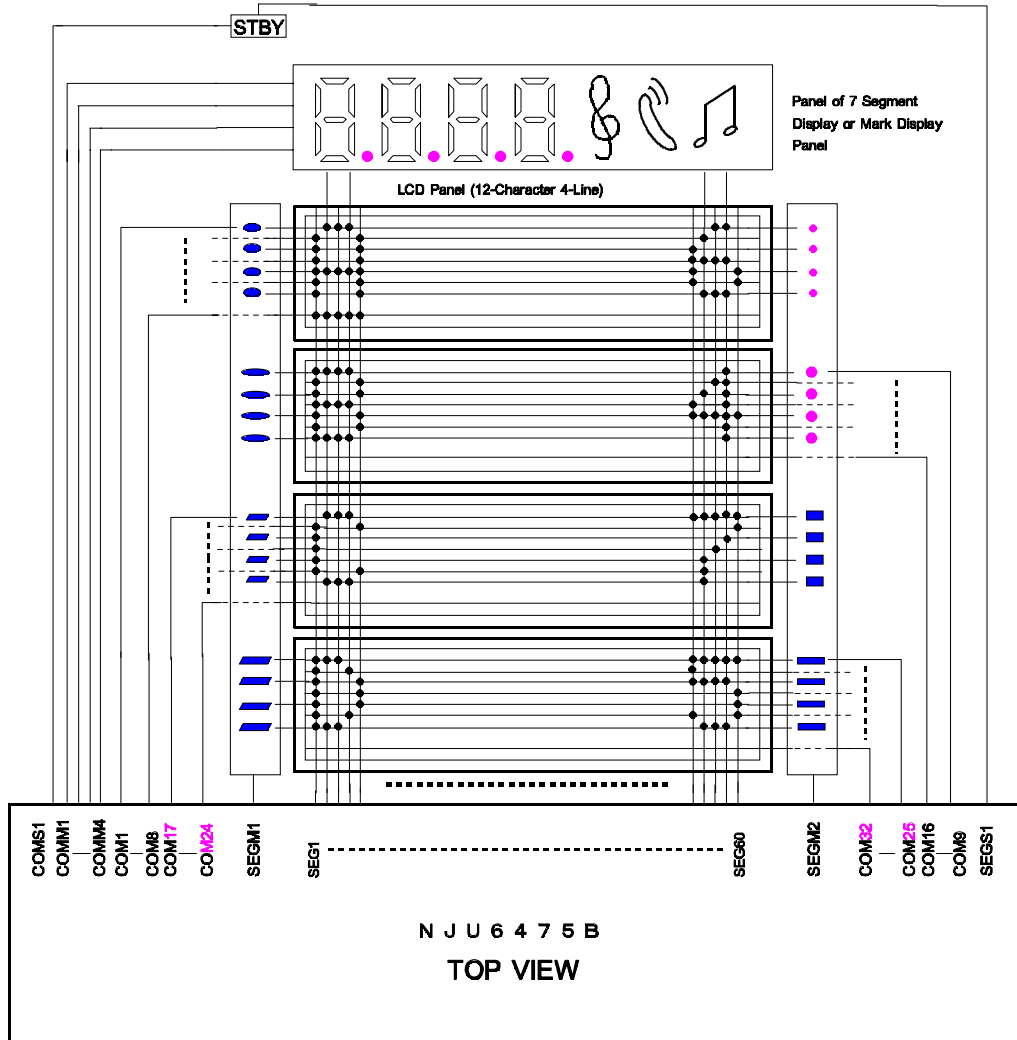

12-Character 4-Line
(Terminal description, Mode B)

MEMO

[CAUTION]

The specifications on this databook are only given for information, without any guarantee as regards either mistakes or omissions. The application circuits in this databook are described only to show representative usages of the product and not intended for the guarantee or permission of any right including the industrial rights.