

# MX621

Advance

July 1990

## Low-Power SPM Detector

### Features

- Meets 12kHz and 16kHz SPM Specifications
- Low-Power CMOS (3-5 Volt Operation)
- SPM Tone Follower and Packet Detection modes
- Programmable Threshold Detect Level

### Applications

- Smartphones
- PABX Systems
- Payphones

### Description

The MX621 is a single-chip, low-power CMOS tone detector designed for use in both PABX and general payphone applications for Subscriber Private Metering (SPM). An external 4.433619MHz crystal accurately defines the Decode and Not-Decode band edges

The MX621 is compatible with 12 and 16kHz SPM systems, and has two pin-selectable operation modes:

1) Tone Follower Mode: A logic "0" is output whenever a tone of the correct frequency and length is detected.

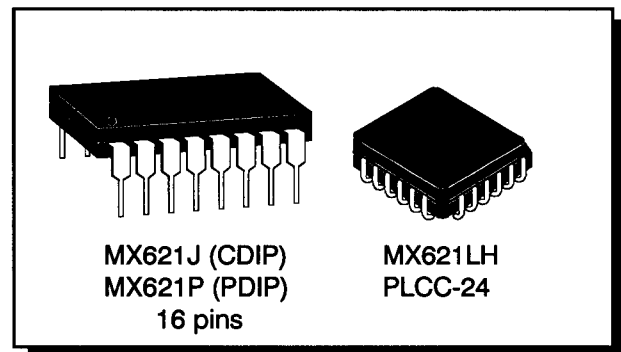

2) SPM Packet Mode: An output is obtained only when both the mark and space timing criteria of an input SPM pulse have been fulfilled.

Through external component selection, the MX621 can be tailored to meet various mark/space periods and detection level thresholds.

The MX621 requires only a 3V supply and has no on-chip filtering, resulting in very low power consumption. The MX621 provides an alternative to the MX611 for SPM applications requiring extremely low power dissipation in a low-noise environment.

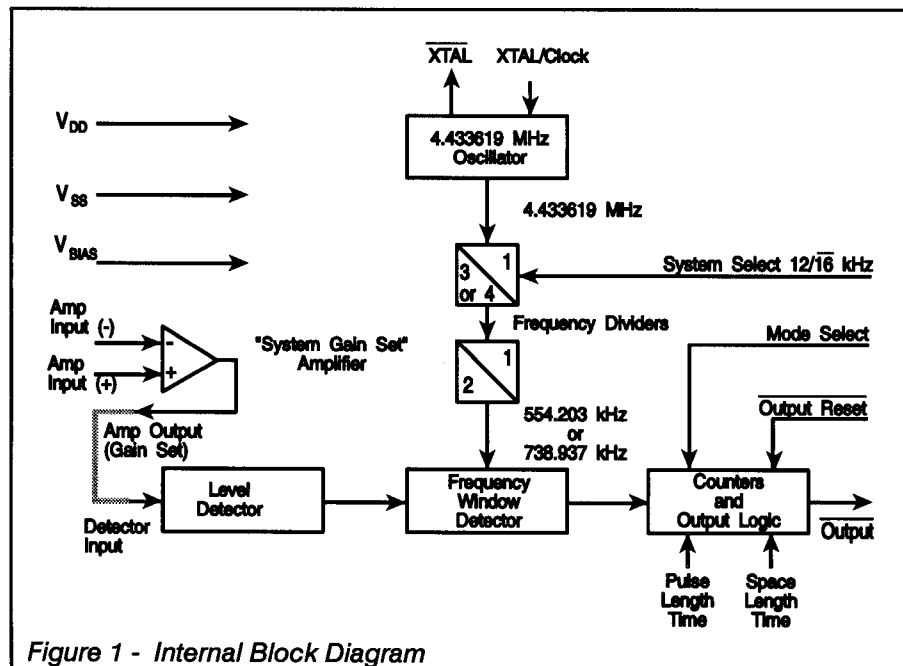

### SPM Background

Subscriber Pulse Metering (SPM) is a popular method of charge metering telephone calls at the PABX and subscriber level in Europe. Charge units are signified by transmitting 12kHz, 16kHz, or 50Hz tonebursts down the line.

Belgium, Finland, France, Germany, Spain, Switzerland, and Sweden are among the countries with SPM standards. Each specifies unique tone pulse repetition rates, pulse lengths, pulse pause lengths, pulse levels, and frequency "must" and "must not" decode bandwidths.

# Pin Function Chart

Pin		Function
J,P	LH	
1	1	Xtal/Clock: Input to the clock oscillator inverter. A single 4.433619MHz Xtal or external clock pulse input is required. See Figure 2.
2	2	V <sub>DD</sub> : The positive supply rail. A single supply in the range 3V to 5V is required.
3	5	Detector Input: "Schmitt Trigger" level detector circuitry whose input thresholds are set internally and dependent on the applied V <sub>DD</sub> . For use with low input signal level systems, this input should be preceded by the System Gain Set Amplifier. To use this input without the System Gain Set Amplifier, the components indicated in Figure 2 (inset) should be used with protection diodes D <sub>1</sub> - D <sub>4</sub> .
4	6	Amplifier Input (+): The positive and negative inputs to the System Gain Set Amplifier. With single or differential inputs this amplifier and its external circuitry can be used to provide the extra gain required to set the device to the user's National Level Specification. External diodes are used at both inputs (if in use) to provide protection when the line input level exceeds the supply rails (above the Absolute Maximum Rating). If this device is ever used without this amplifier, the protection circuitry should be employed at the Detector Input. See Figure 2.
5	7	Amplifier Input (-): The positive and negative inputs to the System Gain Set Amplifier. With single or differential inputs this amplifier and its external circuitry can be used to provide the extra gain required to set the device to the user's National Level Specification. External diodes are used at both inputs (if in use) to provide protection when the line input level exceeds the supply rails (above the Absolute Maximum Rating). If this device is ever used without this amplifier, the protection circuitry should be employed at the Detector Input. See Figure 2.
6	8	Amplifier Output: The output of the System Gain Set Amplifier. It is used with gain-setting components. See Figures 1 and 2.
8	12	V <sub>SS</sub> : The negative supply rail (GND).
9	13	V <sub>BIAS</sub> : The internal analog bias pin. This point is at V <sub>DD</sub> /2 and requires to be externally decoupled to V <sub>SS</sub> via capacitor C <sub>3</sub> .
10	14	Space Length Time: Active only in the SPM Packet Mode, this input, with an external RC network, sets the minimum valid No-Tone (Space) period for the incoming packet using the formula: t <sub>s</sub> = 0.7 (R <sub>6</sub> × C <sub>2</sub> ). If the SPM Packet Mode is not required, these timing components may be omitted and the input left as "No Connect." See page 4.
11	17	Pulse Length Time: Active only in the SPM Packet Mode, this input, with an external RC network, sets the minimum valid Tone period for the incoming packet using the formula: t <sub>m</sub> = 0.7 (R <sub>5</sub> × C <sub>4</sub> ). If the SPM Packet Mode is not required, these timing components may be omitted and the input left as "No Connect." See page 4.
12	18	Output Reset: This input is used only in the SPM Packet Mode. Once an SPM packet has been detected and an output generated (logic "0") from this device, the output remains as set until this input is strobed to a logic "0." This input has an internal 1M# pullup resistor.
13	19	Mode Select: A control pin to select either the Tone Follower Mode or the SPM Packet Mode. A logic "1" selects Tone Follower, and a logic "0" selects SPM Packet. This input has an internal 1M# pullup resistor (Tone Follower).
14	20	Output: The digital output of the SPM Detector. In the Tone Follower Mode, a valid tone gives a logic "0" and no-tone gives a logic "1." Tonebursts and tone dropouts of less than 16 cycles are ignored. In the SPM Packet Mode the output is set to a logic "0" when a valid packet is measured. The output remains as set until reset by a logic "0" at the Output Reset function (see Figure 3).
15	23	System Select: A control pin to set the device to work on either a 12kHz (logic "1") or 16kHz (logic "0") SPM system. This input has an internal 1M# pullup resistor (12kHz).
16	24	Xtal: The output of the clock oscillator inverter (see Figure 2).

*Pin 7 on the MX621J and P and Pins 3, 4, 9, 10, 11, 15, 16, 21, and 22 on the MX621LH have no internal connection—leave them open circuit.*

# Application Information

The information below and on the following pages will help you to calculate the external components required to operate the MX621 as an SPM Detector.

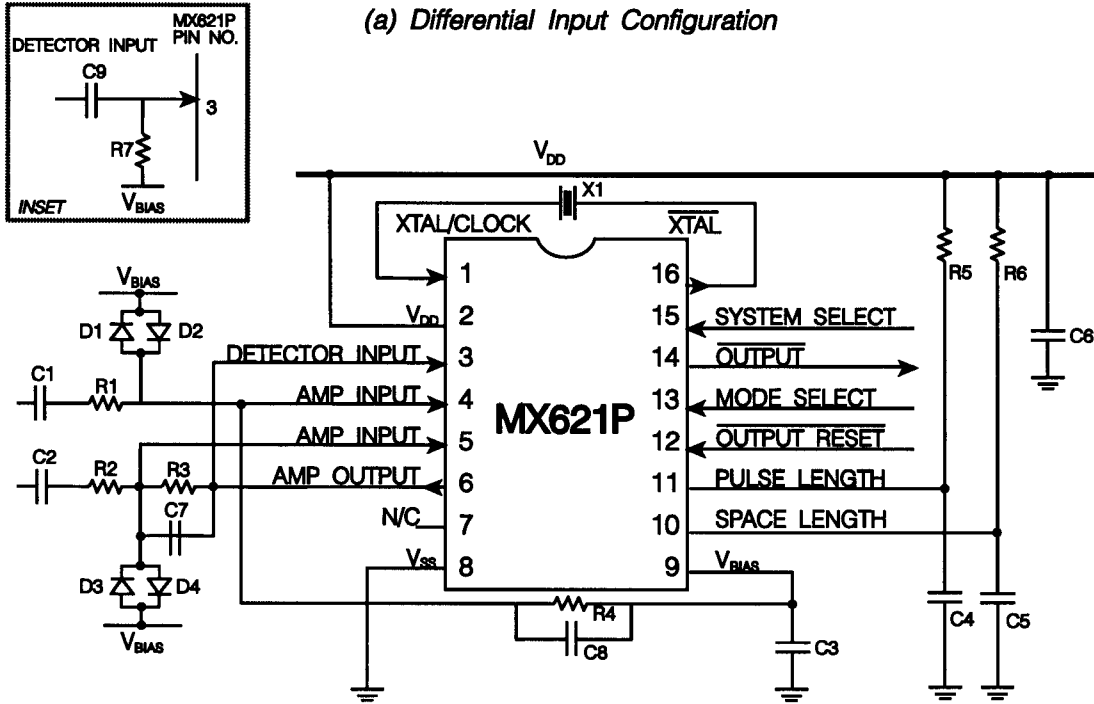

(b) Single Input Configuration

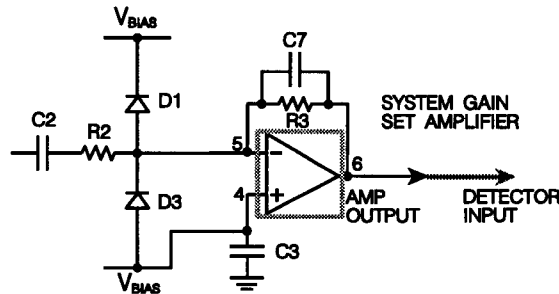

COMPONENT REFERENCES			
Component	Reference	Component	Reference
R <sub>1</sub>	Note 4	C <sub>1</sub>	Note 4
R <sub>2</sub>	Note 4	C <sub>2</sub>	Note 4
R <sub>3</sub>	390k# ± 1.0%	C <sub>3</sub>	1.0λF ± 20%
R <sub>4</sub>	390k# ± 1.0%	C <sub>4</sub>	Note 5
R <sub>5</sub>	Note 5	C <sub>5</sub>	Note 5
R <sub>6</sub>	Note 5	C <sub>6</sub>	1.0λF ± 20%
R <sub>7</sub>	1.0 M#	C <sub>7</sub>	12.0 pF ± 10.0%
D <sub>1</sub> to D <sub>4</sub>	1N4148 or equivalent (small signal type)	C <sub>8</sub>	12.0 pF ± 10.0%
X <sub>1</sub>	4.433619MHz	C <sub>9</sub>	0.1λF ± 10.0%

Figure 2 - Recommended External Components

# Gain Component Calculations

(1) Calculate the MX621 sensitivity.

Device Sensitivity at the Detector Input (Figure 1) is dependant upon the  $V_{DD}$  value and is calculated as:

$$\text{Device Sensitivity} = \frac{0.2 \times V_{DD}}{2 \times \sqrt{2}} \quad (V_{rms})$$

(2) Ascertain the required National (Minimum Will-Decode) and (Maximum Will-Not Decode) Levels.

(3) Calculate the acceptable range of required Gain/Attenuation for the levels in Note 2, using the "System Gain Set" Amplifier.

The gain requirement is calculated as:

$$\text{Max/Min Gain} = \frac{\text{Device Sensitivity}}{\text{Minimum Will-Decode Level}}$$

(or)  $\frac{\text{Maximum Will-Not Decode Level}}$

Choose a gain figure that meets both requirements.

(4) Calculate the gain/attenuation components for the chosen gain.

Gain Components — for a differential input:

$$\begin{aligned} R_1 &= R_2 & C_8 &= C_7 \\ R_3 &= R_4 & C_1 &= C_2 \end{aligned}$$

$$\text{Gain} = \frac{Z_{\text{feedback}} (R_4 / X(C_8))}{Z_{\text{input}} (R_1 + X(C_1))}$$

This calculation approximates as:

$$R_1 = \frac{R_4}{1.2 \times (\text{selected gain})}$$

and  $C_1 = \frac{1}{2\pi \times R_1 \times 6.0\text{kHz}}$

-using the nearest preferred value components.

The values of  $R_1$  and  $C_1$  have been calculated to give a high-pass cut-off between the audio and SPM tone frequencies (approximately 6kHz).  $C_7$  and  $C_8$  are anti-alias components and are calculated for an approximate cut-off frequency of 32kHz.

(5) Timing Components

In the "SPM Packet Mode"  $R_5$  and  $C_4$  set the minimum "Tone" period ( $t_M$ ), and  $R_6$  and  $C_5$  set the minimum "Space" period ( $t_S$ ). They are calculated as follows:

$$t_M = 0.7(R_5 \times C_4) \quad t_S = 0.7(R_6 \times C_5)$$

When calculating Tone and Space times the following points should be taken into consideration:

- (a) Response and De-response times  $t_R$  and  $t_D$ .
- (b) Component tolerances can alter the calculation.
- (c) The MINIMUM expected pulse/space length must be catered for.

(6) Protection Diodes

Since most telephone systems operate at voltages in excess of the Absolute Maximum Limits for damage, diodes  $D_1 - D_4$  are essential for device protection.

(7) Component Tolerances

The tolerances of external components used with this device are dependent upon the required accuracy of the gain and pulse period timings.

# Timing Information

Figure 3 shows the MX621 output timing. Timing value limits are given in Specifications. Note: there is no reaction to pulses or drop-outs of less than the valid Response or De-response time.

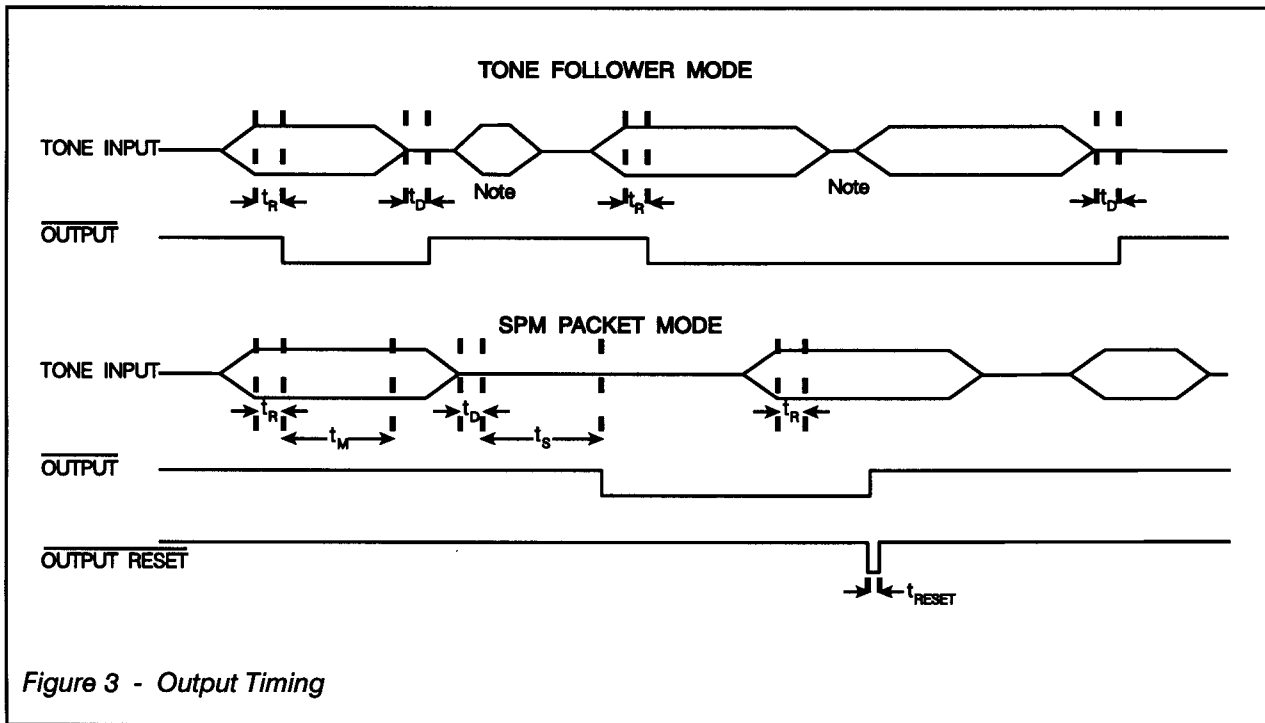

Figure 3 - Output Timing

Example Values — for the MX621 to operate with the West German (16kHz) 'FTZ' Specification

- (a) Min. 'Will Decode' Level = 71.3 mV rms
- (b) Max. 'Will Decode' Level = 10.0 V rms
- (c) Max. 'Will-Not Decode' Level = 34.6 mV rms
- (d) Device Sensitivity @ 3.0 V  $V_{DD}$  ? 212.0 mVrms

Min. Gain Required (d % a) ? 3.0

Max. Gain Allowed (d % c) ? 6.1

Chosen Gain Figure ? 4.0

For a chosen gain figure of 4.0, a minimum Tone length of 80ms, a minimum Space length of 135 ms, and a  $V_{DD}$  of 3.0 V, the required component values are as follows:

$R_1$	82 k#	$C_1$	330 pF
$R_2$	82 k#	$C_2$	330 pF
$R_3$	390 k#	$C_3$	1.0 $\lambda$ F
$R_4$	390 k#	$C_4$	1.0 $\lambda$ F
$R_5$	130 k#	$C_5$	1.0 $\lambda$ F
$R_6$	220 k#	$C_6$	1.0 $\lambda$ F
X1	4.433619MHz	$C_7$	12 pF
		$C_8$	12 pF

Tolerances: Resistors =  $\pm 1\%$ . Capacitors =  $\pm 10\%$ .

# Specifications

## Absolute Maximum Ratings

Exceeding the maximum rating can result in device damage. Operation of the device outside the operating limits is not suggested.

Supply Voltage	-2.8 to 5.0V
Input Voltage at any pin (ref $V_{SS} = 0V$ )	-0.3V to ( $V_{DD} + 0.3V$ )
Sink/source current (supply pins)	$\pm 30$ mA
(other pins)	$\pm 20$ mA
Total device dissipation @ $T_{AMB} 25^{\circ}C$	800 mW max.
Derating	10 mW/ $^{\circ}C$
Operating Temperature	-40 $^{\circ}C$ to +85 $^{\circ}C$
Storage Temperature	-55 $^{\circ}C$ to +125 $^{\circ}C$

## Operating Limits

All devices were measured under the following conditions unless otherwise noted.

$$V_{DD} = 3.0V$$

$$T_{AMB} = 25^{\circ}C$$

$$Xtal/Clock f_c = 4.433619MHz$$

$$Audio\ level\ 0dB\ ref.\ =\ 775mV\ rms.$$

Characteristics	System	Note	Min.	Typ.	Max.	Unit
<b>Static Values</b>						
Supply Voltage ( $V_{DD}$ )			2.8	3.0	5.0	V
Supply Current ( $I_{DD}$ )				1.0		mA
Input Logic "1"		2	2.1			V
Input Logic "0"		2			0.9	V
Output Logic "1"		2	2.4			V
Input Logic "0"		2			0.6	V
<b>Impedances</b>						
"Gain Set" Amplifier Input			1.0			M#
"Gain Set" Amplifier Output					10.0	k#
Analog Detector Input			1.0			M#
Digital Inputs				1.0		M#
Digital Output					10	k#
<b>Dynamic Values</b>						
Sensitivity	12/16kHz	1,2		212.0		mVrms
Required Signal to Noise Ratio		7		45		dB
Upper Detector Threshold		2	1.77	1.8	1.83	V
Lower Detector Threshold		2	1.17	1.2	1.23	V
Amplifier Input Offset				15.0		mV
Xtal Oscillator Frequency				4.433619		MHz
<b>Frequency Discrimination</b>						
'Will-Decode' Frequency Limits	12 kHz		11.82		12.18	kHz
	16 kHz		15.76		16.24	kHz
'Will-Not Decode' Frequency Limits	12 kHz		0		11.52	kHz
	12kHz		12.48			kHz
	16 kHz		0		15.36	kHz
	16 kHz		16.64		50.0	kHz
<b>Timing Information - Fig.3</b>						
Valid Tone Burst Length ( $t_M$ )	12/16kHz	3,4	16.0	-	-	cycles
Valid Space Length ( $t_S$ )	12/16kHz	4	5.0	-	-	ms
Tone Response Time ( $t_R$ )	12kHz	5,7	-	1.7	3.0	ms
	16kHz	5,7	-	1.2	2.0	ms
De-response Time ( $t_D$ )	12kHz	6,7	-	1.7	3.0	ms
	16kHz	6,7	-	1.2	2.0	ms
SPM Output Reset Time ( $t_{reset}$ )	12/16kHz	4	150.0	-	-	ns

## Notes

1. Device sensitivity at the Detector Input pin, or using the 'Gain Set' Amplifier at unity.
2. These values are quoted at 3-volt  $V_{DD}$ , any supply variation will alter thresholds accordingly.
3. Tone Follower mode.
4. SPM Packet mode—in this mode the minimum valid Pulse (Space) length is programmable by means of an RC network on the Pulse (Space) Length Time pin. If no RC network is used, the minimum valid tone length reverts to 16 cycles.
5. The time for the circuit to recognize a valid "Tone" in the Tone Follower Mode.
6. With no noise at the input.
7. The time for the circuit to recognize a valid "No Tone" in the Tone Follower Mode.

## Package Information

The MX621J CERDIP Package is shown in Figure 4. The MX621P is in Fig. 5, The LH package in Fig. 6. For identification purposes the MX621LH has an ident spot adjacent to pin 1 and a chamfered corner between pins 3 and 4.

### To Order:

MX621J: 16-pin Ceramic Dual In-line Package  
 MX621P: 16-pin Plastic Dual In-line Package  
 MX621LH: 24-lead Plastic Leaded Chip Carrier

## Handling Precautions

The MX621 is a CMOS LSI circuit which includes input protection. However, precautions should be taken to prevent static discharges which may cause damage.

Figure 5 - MX621P 16-pin PDIP

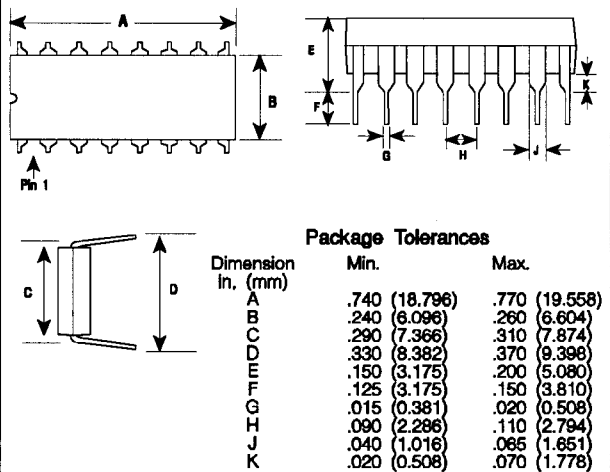

Figure 4 - MX621J 16-pin CERDIP

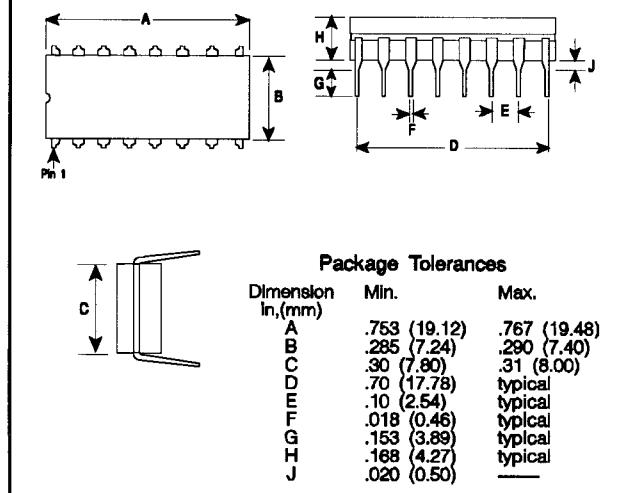
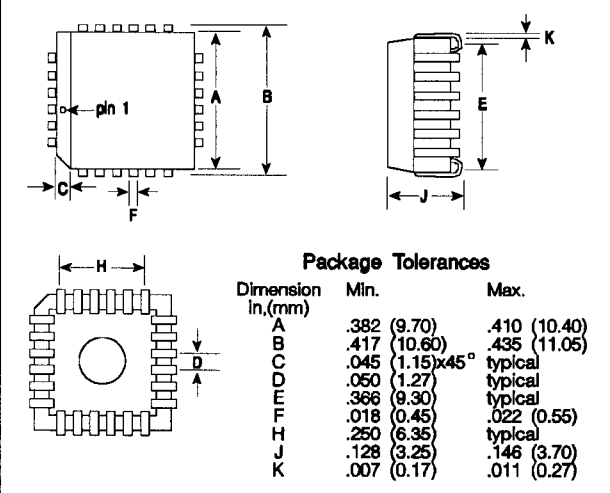

Figure 6 - MX621LH PLCC-24 Package



# MX-COM, INC. ICs are available throughout the free world:

■ in Europe,  
**CONSUMER MICROCIRCUITS, LTD.**  
(A member of CML Microsystems, Plc.)  
1 Wheaton Rd.  
Witham, Essex, England CM8 3TH

Phone: (0376) 513833  
Telex: 9932 CMICRO G  
Fax: (0376) 518247

■ in Hong Kong,  
**TEKCOMP ELECTRONICS, LTD.**  
514 Bank Centre,  
636 Nathan Rd.  
Kowloon, Hong Kong

Phone: (852) 3880629  
Telex: 38513 TEKHL HX  
Fax: (852) 7805871

■ in Japan,  
**TEKSEL CO., LTD.**  
Kanagawa Science Park  
R&D C-4F  
100-1, Sakado, Takatsu-ku  
Kawasaki 213, Japan

Phone: (044) 812-7430  
Telex: 3842196 TEKSEL  
Fax: (044) 812-7433

Osaka office  
Phone: (06) 391-8661  
Fax: (06) 391-8684

■ in Korea,  
**S-TEC INTERNATIONAL CO., LTD.**  
Yoido P.O. Box 577  
Room #1305, Yoido Department Store Bldg.  
36-2, Yoido Dong, Yeongdeungpo-Ku  
Seoul, 150-010, Korea

Phone: (02) 784-6800  
Telex: K23456 STECI  
Fax: (02) 784-8600

■ in Taiwan,  
**MITRONICS INTERNATIONAL CORP.**  
Hyatt Tower 7F,  
No. 696 Tung Hua South Road  
Taipei, Taiwan, R.O.C.

Phone: (02) 709-7626  
Telex: 12621 MITRONIC  
Fax: (02) 776-1394

in the Americas,

## **MX-COM, INC.**

4800 Bethania Station Rd.  
Winston-Salem, NC27105-1201

Phone: (919) 744-5050  
(800) 638-5577  
Fax: (919) 744-5054  
Intl. Telex: 5101012852



### **CAUTION**

MOS Device. May be damaged  
by static discharge. Observe  
handling precautions.





**CML Microcircuits**

COMMUNICATION SEMICONDUCTORS

## CML Product Data

In the process of creating a more global image, the three standard product semiconductor companies of CML Microsystems Plc (*Consumer Microcircuits Limited (UK)*, *MX-COM, Inc (USA)* and *CML Microcircuits (Singapore) Pte Ltd*) have undergone name changes and, whilst maintaining their separate new names (*CML Microcircuits (UK) Ltd*, *CML Microcircuits (USA) Inc* and *CML Microcircuits (Singapore) Pte Ltd*), now operate under the single title **CML Microcircuits**.

These companies are all 100% owned operating companies of the CML Microsystems Plc Group and these changes are purely changes of name and do not change any underlying legal entities and hence will have no effect on any agreements or contacts currently in force.

### CML Microcircuits Product Prefix Codes

Until the latter part of 1996, the differentiator between products manufactured and sold from MXCOM, Inc. and Consumer Microcircuits Limited were denoted by the prefixes MX and FX respectively. These products use the same silicon etc. and today still carry the same prefixes. In the latter part of 1996, both companies adopted the common prefix: CMX.

This notification is relevant product information to which it is attached.

### CML Microcircuits (USA) [formerly MX-COM, Inc.] Product Textual Marking

On CML Microcircuits (USA) products, the 'MX-COM' textual logo is being replaced by a 'CML' textual logo.

Company contact information is as below:



**CML Microcircuits  
(UK) Ltd**

COMMUNICATION SEMICONDUCTORS

Oval Park, Langford, Maldon,  
Essex, CM9 6WG, England  
Tel: +44 (0)1621 875500  
Fax: +44 (0)1621 875600  
uk.sales@cmlmicro.com  
www.cmlmicro.com



**CML Microcircuits  
(USA) Inc.**

COMMUNICATION SEMICONDUCTORS

4800 Bethania Station Road,  
Winston-Salem, NC 27105, USA  
Tel: +1 336 744 5050,  
0800 638 5577  
Fax: +1 336 744 5054  
us.sales@cmlmicro.com  
www.cmlmicro.com



**CML Microcircuits  
(Singapore) Pte Ltd**

COMMUNICATION SEMICONDUCTORS

No 2 Kallang Pudding Road, 09-05/  
06 Mactech Industrial Building,  
Singapore 349307  
Tel: +65 7450426  
Fax: +65 7452917  
sg.sales@cmlmicro.com  
www.cmlmicro.com