

# M54640P

STEPPER MOTOR DRIVER

## DESCRIPTION

The M54640P is a semiconductor IC to drive a stepper motor by the bipolar method.

## FEATURES

- Bipolar and constant-current drive
- Wide current control range (20 – 800mA)
- Wide supply voltage drive range (10 – 40V)
- Built in flywheel diodes
- Current level can be changed by steps or continuously.
- Built in a thermal shutdown circuit

## APPLICATION

Printer, FDD, HDD, Fax

## FUNCTION

The M54640P drives a stepper motor by the bipolar drive method to change the current direction of a single coil and controls the current direction with PHASE input pin. In order to obtain higher efficiency, the constant current drive system to control the coil current is introduced. The current value can be selected among four levels (0 to max.) by selecting the combination of three internal comparators by logic input. It also can be continuously changed by controlling the reference voltage. Conversion to voltage is conducted by the current value sensing resistor ( $R_s$ ) and the voltage is sensed with

## PIN CONFIGURATION (TOP VIEW)

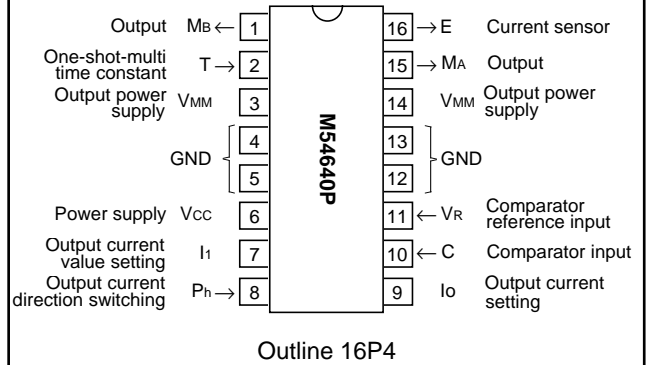

each comparator, and then each comparator output triggers monomulti and the current is cut for a certain time ( $t_{OFF}$ ) by utilizing the inductance of the coil.

Also, diodes needed for chopping and a thermal shutdown circuit as a countermeasure against overvoltage are built in this circuit.

## BLOCK DIAGRAM

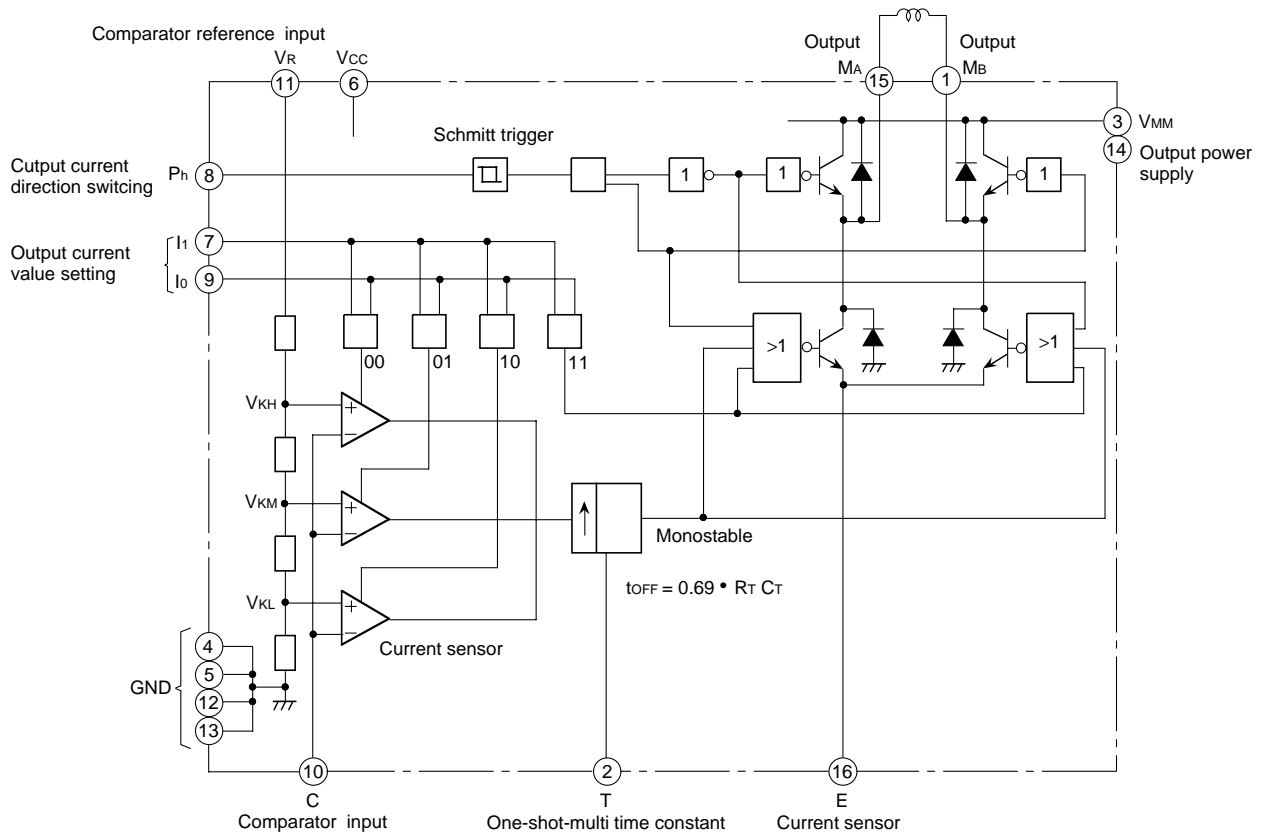

# M54640P

## STEPPER MOTOR DRIVER

### ABSOLUTE MAXIMUM RATINGS (Ta=25°C, unless otherwise noted)

Symbol	Parameter	Conditions	Ratings	Unit
V <sub>CC</sub>	Supply voltage		-0.3 – 7	V
V <sub>MM</sub>	Output supply voltage		-0.3 – 45	V
V <sub>L</sub>	Logic input voltage		-0.3 – 6	V
V <sub>C</sub>	Analog input voltage		-0.3 – V <sub>CC</sub>	V
V <sub>R</sub>	Comparative input voltage		-0.3 – 15	V
I <sub>L</sub>	Logic input current		-10	mA
I <sub>C</sub>	Analog input current		-10	mA
I <sub>MM</sub>	Output supply current		±1000	mA
P <sub>d</sub>	Power dissipation	Mounted on a board	1.92	W
T <sub>opr</sub>	Operating temperature		-20 – 75	°C
T <sub>stg</sub>	Storage temperature		-55 – 125	°C

Note. Every voltage value is measured when the voltage at GND pin is 0V. The maximum and the minimum of each voltage value are shown in absolute values.  
Regarding current directions, inflow current is shown in a positive value and outflow current is shown in a negative value. The maximum and the minimum of each current value are shown in absolute values.

### RECOMMENDED OPERATING CONDITIONS (Ta=25°C, unless otherwise noted)

Symbol	Parameter	Limits			Unit
		Min.	Typ.	Max.	
V <sub>CC</sub>	Supply voltage	4.75	5	5.25	V
V <sub>MM</sub>	Output supply voltage	10		40	V
I <sub>O</sub>	Output current	20		800	mA
t <sub>PLH</sub>	Logic input rise time			2	μs
t <sub>PHL</sub>	Logic input fall time			2	μs
T <sub>ON</sub>	Thermal shutdown temperature		175		°C

### ELECTRICAL CHARACTERISTICS (V<sub>CC</sub>=5V, Ta=25°C, unless otherwise noted)

Symbol	Parameter	Test conditions	Limits			Unit
			Min.	Typ.	Max.	
V <sub>IH</sub>	Logic input voltage	V <sub>CC</sub> =5V	2.0		V <sub>CC</sub>	V
V <sub>IL</sub>			0		0.8	
V <sub>CH</sub>	Comparator threshold	V <sub>R</sub> =5V, I <sub>0</sub> =I <sub>1</sub> =0	400	430	450	mV
V <sub>CM</sub>		V <sub>R</sub> =5V, I <sub>0</sub> =1, I <sub>1</sub> =0	240	260	280	
V <sub>CL</sub>		V <sub>R</sub> =5V, I <sub>0</sub> =0, I <sub>1</sub> =1	75	90	100	
I <sub>CO</sub>	Comparator input current		-20		20	μA
I <sub>OFF</sub>	Output cutoff current	I <sub>0</sub> =I <sub>1</sub> =1 (Ta=25°C)			100	μA
V <sub>sat</sub>	Saturation voltage	The voltage at the sensing resistor is not included. I <sub>0</sub> =500mA			4.0	V
t <sub>OFF</sub>	Cutoff time	V <sub>MM</sub> =10V, t <sub>ON</sub> ≥5μs	25	30	35	μs
t <sub>d</sub>	Turnoff delay	Ta=25°C, dV <sub>K</sub> /dt≥50mV/μs		1.6	2.0	μs
I <sub>CC</sub>	Supply current	V <sub>CC</sub> =5V			25	mA
I <sub>IH</sub>	Logic input current	"H"	V <sub>I</sub> =2.4V		20	μA
I <sub>IL</sub>		"L"	V <sub>I</sub> =0.4V		-0.4	mA

**SWITCHING CHARACTERISTICS**

**Test circuit**

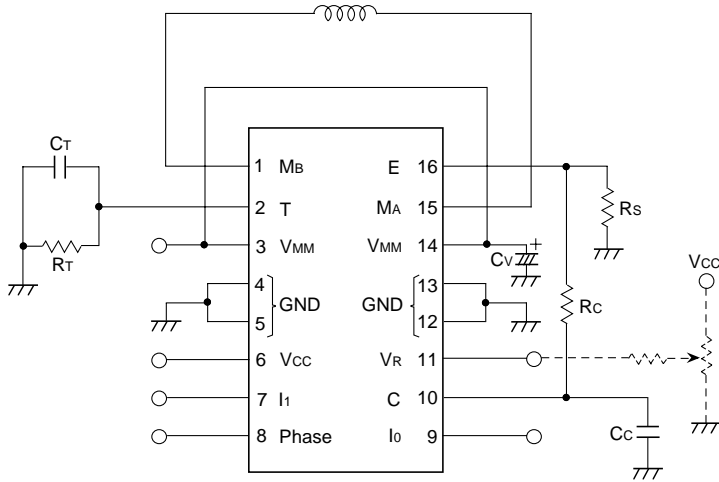

- Rs : 1Ω
- Rc : 1kΩ
- RT : 56kΩ
- Cc : 820pF
- Ct : 820pF
- Cv : 47μF

**Switching waveforms**

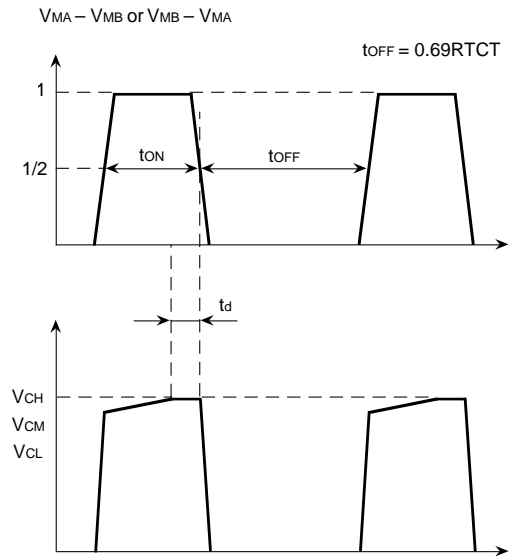

**APPLICATION DESCRIPTION**

- PHASE INPUT  
Phase input decides the output mode.

PHASE	MA	MB
H	H	L
L	L	H

- Io, I1  
Io and I1 fixed based on the comparison voltage Vr decide the output current level.  
The current level can be continuously changed by changing the voltage at Vr continuously.

Io	I1	Current level
H	H	0
L	H	Low
H	L	Average
L	L	High

- Current sensor  
When the voltage fall at the current sensing resistor and the selected current level becomes of the same level, the comparator triggers the monostable. Then, the output stage is cut off for a certain time (tOFF). During this cutoff time, the current volume decreases slightly and falls short of the comparison level. After the cutoff time (tOFF), the output stage is in ON state again. This operation is repeated.

- Single pulse generator  
At the comparator output rise edge, the monostable is triggered. The pulse width of the monostable at the external timing Rt and Ct is as follows.

$$t_{OFF} = 0.69 \times R_t C_t$$

Retrigger during tOFF is neglected.

- Analog control  
The output current level can be continuously changed by changing the voltage at Vr or the feedback voltage to the comparator.

**TIMING CHART**

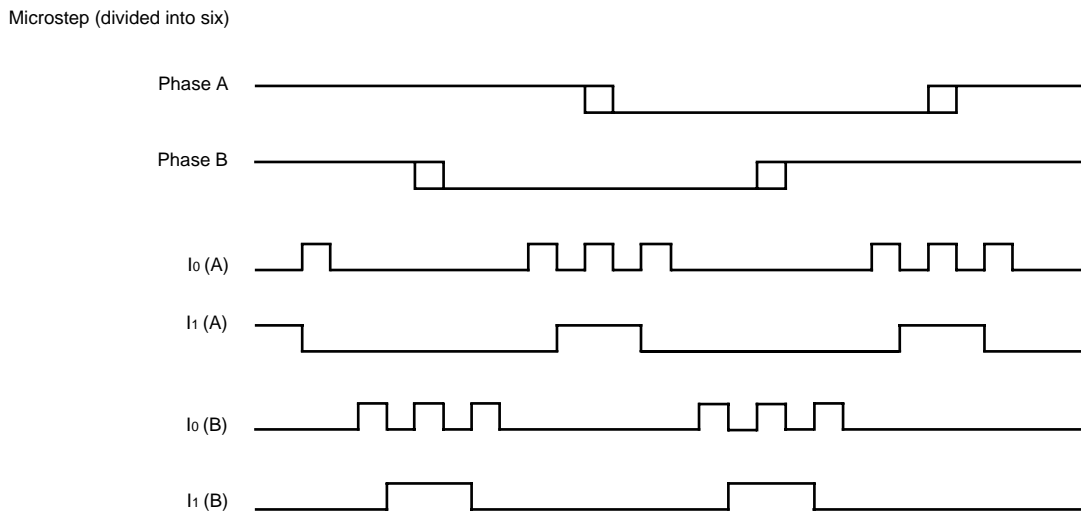
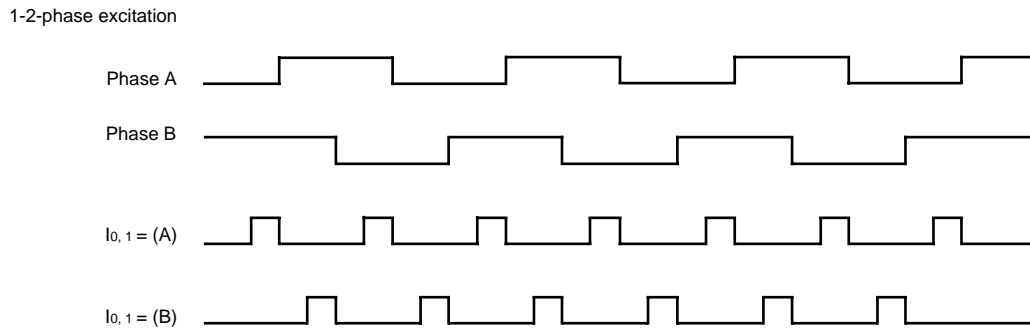
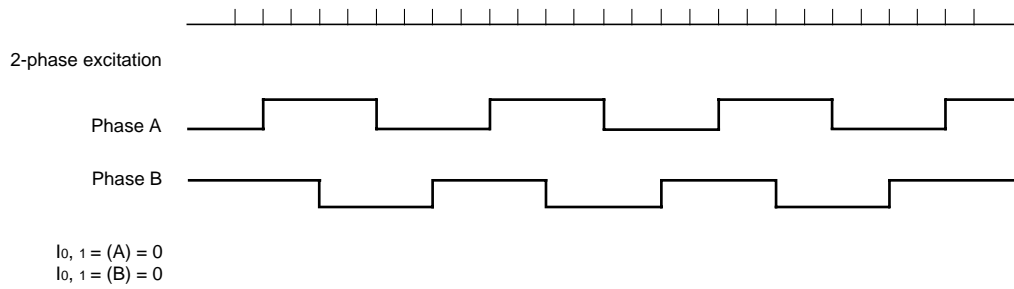

**TYPICAL CHARACTERISTICS (Absolute maximum ratings)**

Safety operating temperature

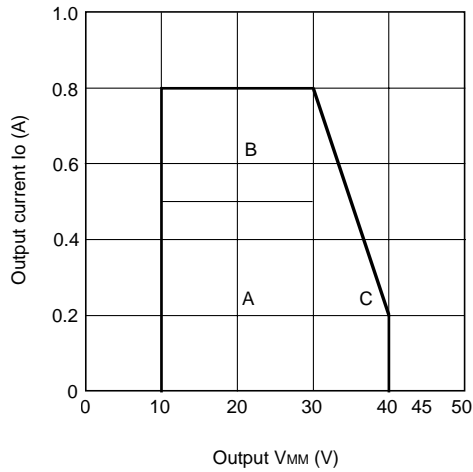

- A : Recommended
- B : Schottky diodes should be externally connected between output pins and power supply pins.
- C : Schottky diodes should be externally installed between output pins and power supply pins and between output pins and GND pin.

Thermal derating

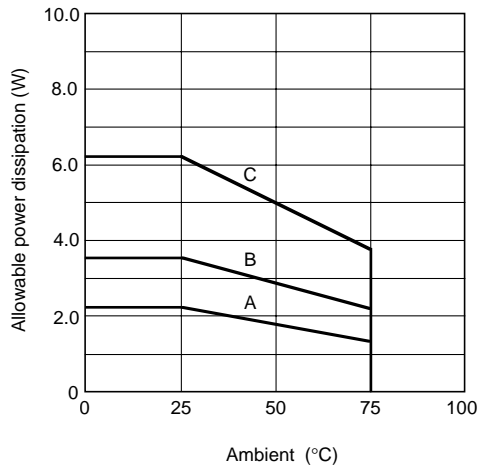

- $\theta_{j-c} = 10^{\circ}\text{C/W}$
- A : Mounted on a 25cm<sup>2</sup> glass epoxy board which is coated with copper on one side.  
 $\theta_{c-a} = 45^{\circ}\text{C/W}$
- B : 10cm<sup>2</sup> aluminum heat sink (1t) is used.  
 $\theta_{c-a} = 25^{\circ}\text{C/W}$
- C : 100cm<sup>2</sup> aluminum heat sink (1t) is used.  
 $\theta_{c-a} = 10^{\circ}\text{C/W}$   
 $T_{j(max)} = 150^{\circ}\text{C}$

**APPLICATION EXAMPLE**

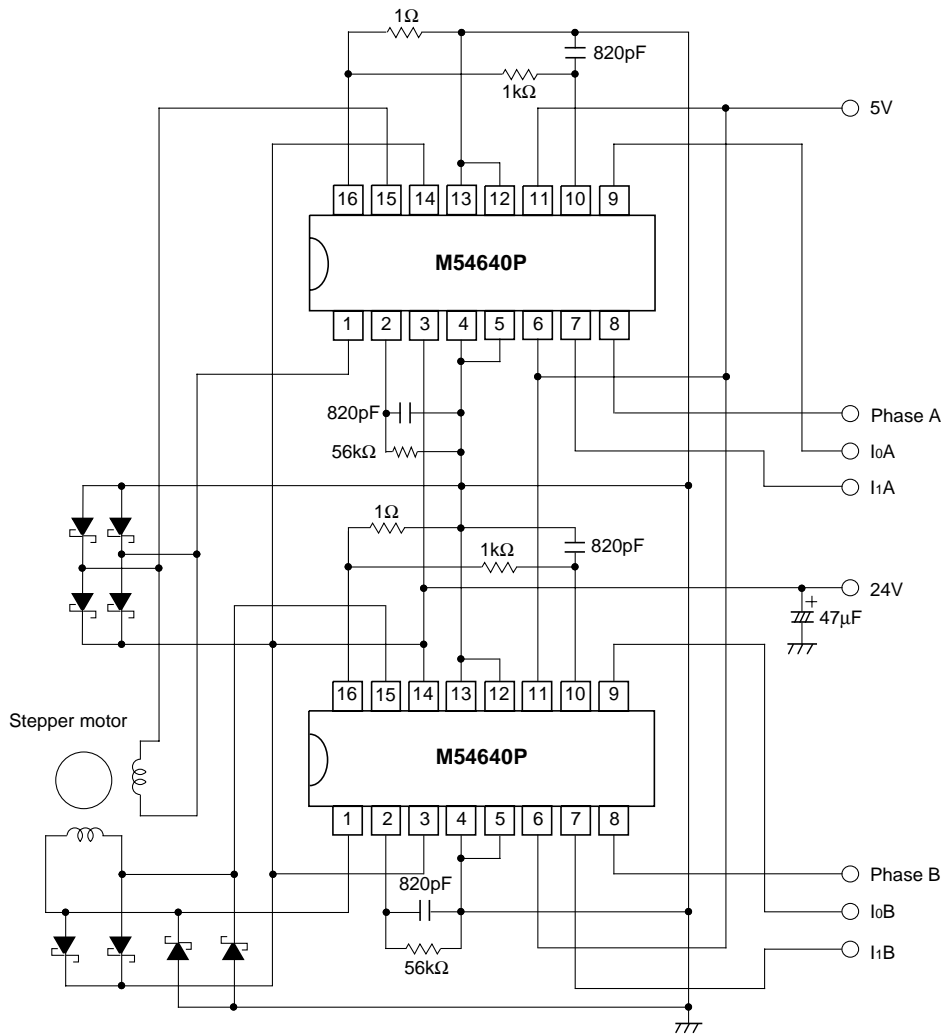

**PRECAUTIONS FOR USE**

- (1) When the whole output current changes by a large margin (for example, when overheat protection operation causes intermittent flow of output current), the supply voltage may undergo a change. Therefore, selection and wiring of power supply should be conducted cautiously to avoid such a situation that the supply voltage exceeds the absolute maximum ratings.
- (2) When the supply voltage changes by a large margin, the operation of this IC may become unstable. In this case, the change of supply voltage can be controlled by connecting a capacitor at the point near to IC pin between Vcc pin and GND pin. (See above application example.)

(3) Thermal shutdown function

- The state of thermal shutdown operation may differ according to the way of wiring within a board. Therefore, sufficient board evaluation should be conducted before use. When the board is changed, operation on the replacing board should be evaluated.
- The circuit board on which this IC is mounted is designed to realize low impedance between power supply and output pin. Therefore, it is desirable to take a safe measure such as fixing a fuse to avoid such a situation that the board is damaged by a fire when output pin is internally short-circuited by excessively applied surge voltage by accident.