

Design Idea DI-57

DPA-Switch™

60 W DC-DC Converter

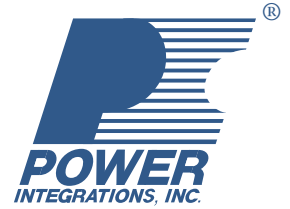

Application	Device	Power Output	Input Voltage	Output Voltage	Topology
Telecom	DPA426R	60 W	36-75 VDC	12 V	Flyback

Design Highlights

- Low cost 400 kHz flyback design
- Simple Zener referenced 12 V output
- Efficiency – 82% at 36 VDC and full load
- Low component count
- Accurate line OV and UV protection
- Thermal, short circuit and output overload protection
- No current sense components

Operation

DPA-Switch greatly simplifies the design compared to a discrete implementation. Resistor R1 programs the under/over voltages and linearly reduces the maximum duty cycle with input voltage to prevent core saturation during load transients. Resistor R3 programs the DPA-Switch current limit at 85% of nominal to

minimize fault and overload power. Drain voltage clamping is provided by diode D4 and Zener diode VR1 with optional components C4 and R2 to provide high frequency snubbing.

The output is rectified by diode D2 with optional high frequency damping from components C9, R15 and R16. The output capacitors are alternated to share the ripple current evenly between the Oscon capacitors (C10-14) and the ceramic capacitors (C15-C18). A final decoupling ceramic capacitor C19 is placed at the output pins of the power supply.

Output regulation is taken from the +12 V output. Zener diode VR2 is DC-biased by resistor R7 with the opto-diode of U2 providing feedback and resistor R6 programming the gain. Optional capacitor C8 implements a soft-finish network to slow the rise of the output voltage at start-up.

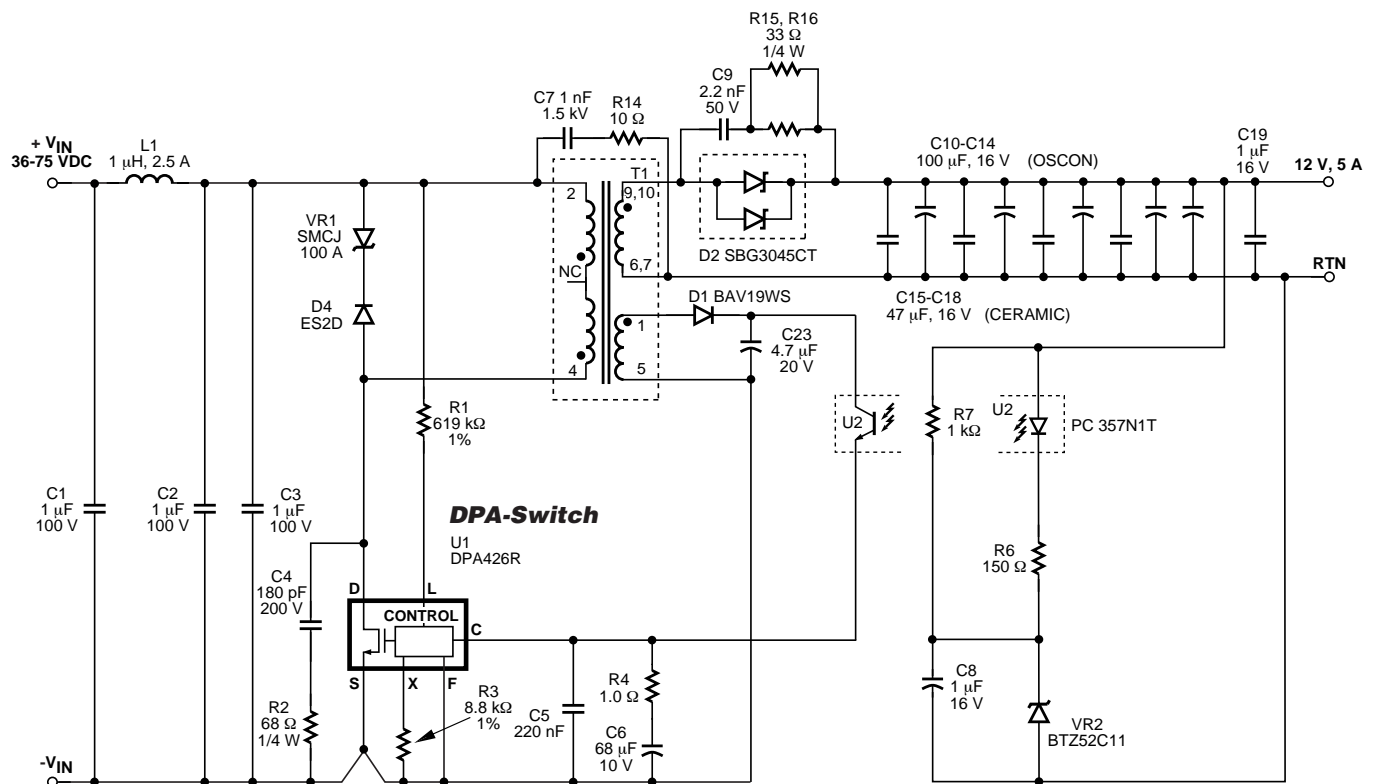

Figure 1. DPA426R - 60 W, 12 V, 5 A DC-DC Converter.

PI-3662-082603

The bias winding is rectified and filtered by D1 and C23 and provides operating power to the *DPA-Switch*. The regulation is fed back from the secondary through the opto-transistor of U2.

Key Design Points

- For the nominal under-voltage set point V_{UV} :

$$R1 = (V_{UV} - 2.35) / 50 \mu A$$

$$V_{OV} = (R1 \times 135 \mu A) + 2.5 V$$
- For highest efficiency designs: use continuous conduction mode operation, this design uses approximately 0.5 KRP; minimize turns in the transformer and at this (60 W) power level, keep AC flux density $BM < 1100$ Gauss; fully fill a single layer for each winding to minimize leakage inductance and maximize copper fill factor; if possible use a Schottky rectifier diode (D2) with a low-forward drop.
- The transformer primary is split in order to minimize leakage inductance to obtain better efficiency.
- Tighter output voltage tolerance is possible by using a TL431 (and associated components) in place of the Zener diode VR2.
- Follow good layout practices:
 - For length of the secondary current loop from transformer pins 9 & 10, diode D2 and capacitors C10 to C18 and back to pins 6 & 7 of the transformer: ensure identical path length for each of the capacitors C10 to C18 to ensure they equally share the ripple current.

TRANSFORMER PARAMETERS	
Core Material	Ferroxcubed P/N: EFD25 3F3
Bobbin	10-pin EFD25 surface mount bobbin
Winding Details	Primary 8T + 8T, 2 x 24 AWG Bias 5T, 1 x 34 AWG +12 V 5T, 4 x 27 AWG
Winding Order and Pin Numbers	Primary-1 (4-NC), Bias (1-5), + 12 V (9, 10-6, 7), Primary-2 (NC-2)
Primary Inductance	21 $\mu H \pm 25\%$ (at 400 kHz)
Primary Resonant Frequency	3.0 MHz (minimum)
Leakage Inductance	1 μH (maximum)

Table 1. Transformer Design Parameters.

For the latest updates, visit our Web site: www.powerint.com

Power Integrations reserves the right to make changes to its products at any time to improve reliability or manufacturability. Power Integrations does not assume any liability arising from the use of any device or circuit described herein, nor does it convey any license under its patent rights or the rights of others. The products and applications illustrated herein (including circuits external to the products and transformer construction) may be covered by one or more U.S. and foreign patents or potentially by pending U.S. and foreign patent applications assigned to Power Integrations. A complete list of Power Integrations' patents may be found at www.powerint.com.

The PI Logo, **TOPSwitch**, **TinySwitch**, **LinkSwitch** and **EcoSmart** are registered trademarks of Power Integrations, Inc. **PI Expert** and **DPA-Switch** are trademarks of Power Integrations, Inc. ©Copyright 2003, Power Integrations, Inc.

WORLD HEADQUARTERS

San Jose, CA USA.
Customer Service:
Phone: +1-408-414-9665
Fax: +1-408-414-9765
e-mail: usasales@powerint.com

AMERICAS

Buford, GA USA
Phone: +1-678-714-6033
Fax: +1-678-714-6012
e-mail: usasales@powerint.com

CHINA (SHANGHAI)

Shanghai, China
Phone: +86-21-6215-5548
Fax: +86-21-6215-2468
e-mail: chinasales@powerint.com

APPLICATIONS HOTLINE

World Wide +1-408-414-9660

CHINA (SHENZHEN)

Shenzhen Guangdong, China
Phone: +86-755-8367-5143
Fax: +86-755-8377-9610
e-mail: chinasales@powerint.com

GERMANY

Muenchen, Germany
Phone: +49-895-527-3910
Fax: +49-895-527-3920
e-mail: eurosales@powerint.com

INDIA (TECHNICAL SUPPORT)

Bangalore, India
Phone: +91-80-226-6023
Fax: +91-80-228-9727
e-mail: indiasales@powerint.com

APPLICATIONS FAX

World Wide +1-408-414-9760

ITALY

Milano, Italy
Phone: +39-028-928-6001
Fax: +39-028-928-6009
e-mail: eurosales@powerint.com

JAPAN

Kanagawa, Japan
Phone: +81-45-471-1021
Fax: +81-45-471-3717
e-mail: japansales@powerint.com

KOREA

Seoul, Korea
Phone: +82-2-782-2840
Fax: +82-2-782-4427
e-mail: koreasales@powerint.com

SINGAPORE (ASIA PACIFIC HEADQUARTERS)

Singapore
Phone: +65-6358-2160
Fax: +65-6358-2015
e-mail: singaporesales@powerint.com

TAIWAN

Taipei, Taiwan, R.O.C.
Phone: +886-2-2727-1221
Fax: +886-2-2727-1223
e-mail: taiwansales@powerint.com

UK (EUROPE & AFRICA HEADQUARTERS)

United Kingdom
Phone: +44-1344-462-300
Fax: +44-1344-311-732
e-mail: eurosales@powerint.com

