

5.8GHz Medium Power Amplifier

GaAs Monolithic Microwave IC

Description

The CHA5215a is a MMIC multifunction integrating a 3-stage medium power amplifier, a gain control and an output detector. A high saturated output power allows a linear operating point for multichannel communication applications. The output power can be controlled thanks to the combination of a detected output voltage and an important gain control dynamic range.

The circuit is manufactured with a standard 0.7 μ m implanted power MESFET, air bridges, via holes through the substrate and electron beam gate lithography process. It is supplied in chip form or in ceramic flat-pack package.

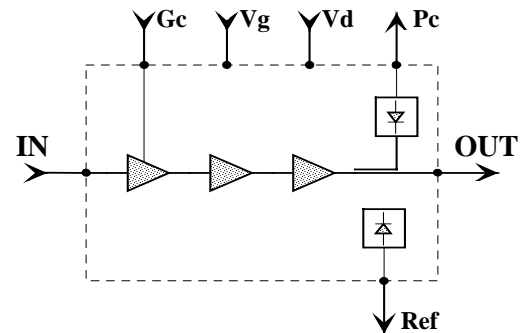

Block diagram

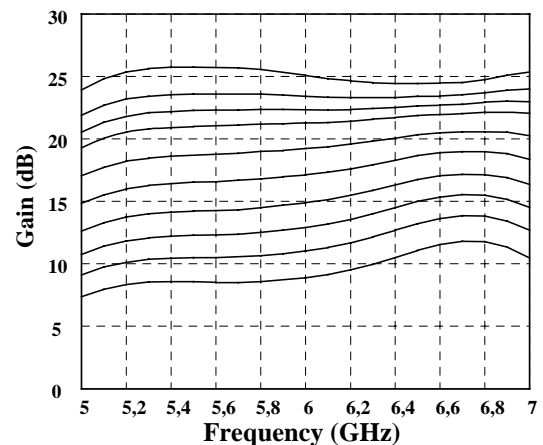

Main Features

- Wide operating frequency range
- High saturated output power
- High linearity
- High gain
- High dynamic gain control
- Output power monitor
- Chip dimensions : 2.47 x 1.27 x 0.10 mm

Main Characteristics

Tamb = +25°C

Symbol	Parameter	Min	Typ	Max	Unit
Fop	Operating frequency range	5	5.8	7	GHz
Gmax	Maximum gain		25		dB
Δ G	Gain control range	10	15		dB
Psat	Saturated output power		27		dBm

ESD Protections : Electrostatic discharge sensitive device observe handling precautions !

Electrical Characteristics

Tamb = +25°C

Symbol	Parameter	Test Conditions	Min.	Typ.	Max	Unit
Fop	Operating frequency range		5	5.8	7	GHz
Glin	Linear gain (Gc=-5V)			25		dB
Gdr	Gain control dynamic range		10	15		dB
Gc	Gain control voltage		-5		0	V
Pout	Saturated output power			27		dBm
Sdet	Output power monitor sensitivity			-5		mV/mW
Vref	Reference monitor voltage			550		mV
RLin	Input return loss (full band) (2)		7	12		dB
RLout	Output return loss (2)			6		dB
Vd	Positive supply voltage (1)			9		V
Id	Positive supply current			330	400	mA
Vg	Negative supply voltage			-1.4		V
Ig	Negative supply current				15	mA

(1) Depending on the application a trade-off can be obtained between linearity and power consumption by adjusting the positive supply voltage (from 6 to 9V).

(2) The return loss can be improved by using a simple matching network (available on request).

Absolute Maximum Ratings (1)

Tamb = +25°C

Symbol	Parameter	Values	Unit
Vd	Positive supply voltage	10	V
Vg	Negative supply voltage	-6 to 0 (3)	V
Gc	Gain control voltage	-6 to 0.6	
Pin	Maximum peak input power overdrive (2)	20	dBm
Top	Operating temperature range	-50 to +70	°C
Tstg	Storage temperature range	-55 to +155	°C

(1) Operation of this device above anyone of these parameters may cause permanent damage

(2) Duration < 1s

(3) Choose Vg in order to have Id ≤ 400mA when Vd is applied

Typical On Wafer Scattering Parameters

Bias Conditions : Vd = +5V Id=330mA (Vg = -1.4V) Gc = -5V

Freq. GHz	S11 dB	S11 /°	S12 dB	S12 /°	S21 dB	S21 /°	S22 dB	S22 /°
4	-9.23	5.6	-47.73	162.4	0.33	-78.2	-8.28	105.5
4.1	-9.05	0.4	-48.42	142.3	2.86	-78.2	-7.72	90.6
4.2	-8.84	-5	-48.78	129.4	5.44	-89.7	--7.46	77.4
4.3	-8.65	-10.8	-50.4	113.1	7.93	-89.7	-7.22	-64.7
4.4	-8.44	-16.8	-50.72	101.3	10.36	-110.2	-6.96	52.6
4.5	-8.25	-23.2	-51.79	88.3	12.76	-110.2	-6.69	52.6
4.6	-8.07	-30.1	-51.93	73.9	15.1	-136.9	-6.38	-27.5
4.7	-7.93	-37.5	-52.56	59.8	17.38	-122.7	-6.1	13.8
4.8	-7.89	-45.4	-52.92	41.2	19.49	-171.3	-5.94	-0.17
4.9	-7.99	-53.7	-53.56	22.4	21.31	-153.1	-6.03	-15.9
5	-8.27	-61.5	-54.49	-0.2	22.75	146.5	-6.46	-30.7
5.1	-8.64	-68.7	-55.71	-22.4	23.74	168.2	-7.27	-44
5.2	-9.03	-74.9	-57.22	-45.7	24.35	102.9	-8.33	-54.2
5.3	-9.39	-80.9	-58.74	-69.8	24.69	124.4	-9.44	-61
5.4	-9.73	-86.6	-60.04	-93.3	24.83	63.8	-10.35	-64.5
5.5	-10.1	-92.4	-60.95	-119.4	24.88	82.7	-10.93	-66
5.6	-10.52	-97.9	-61.36	-144.1	24.86	29.1	-11.21	-66.8
5.7	-11	-103.1	-61.75	-168	24.77	46.1	-11.25	-67.8
5.8	-11.56	-107.6	-61.42	170.3	24.65	-2.4	-11.13	-68.9
5.9	-12.09	-111.1	-60.99	150.8	24.49	13	-10.98	-70.7
6	-12.62	-113.2	-60.57	134.4	24.33	-31	-10.74	-72.5
6.1	-13.05	-114.5	-60.34	117.6	24.19	-17.1	-10.54	-74.4
6.2	-13.21	-114.3	-59.89	105.9	24.09	-57.5	-10.35	-76.4
6.3	-13.14	-114.1	-59.38	93.5	24.03	-44.5	-10.15	-78.1
6.4	-12.77	-114.4	-58.47	82.1	23.98	-82.9	-9.92	-79.2
6.5	-12.18	-115.7	-57.61	70.1	24.02	-70.3	-9.63	-80.5
6.6	-11.48	-117.9	-56.81	59.1	24.09	-108.1	-9.27	-81.7
6.7	-10.65	-121.7	-55.59	44.2	24.2	-95.4	-8.79	-83.3
6.8	-9.76	-126.9	-55.19	31.3	24.37	-134.9	-8.35	-85.5
6.9	-8.9	-133.7	-54.39	17.7	24.52	-121.1	-7.86	-88.3
7	-8.03	-141.9	-53.67	0.7	24.65	-165.1	-7.4	-92

Typical On Wafer Scattering Parameters

Bias Conditions : $V_d = +5V$ $I_d = 330mA$ ($V_g = -1.4V$) $G_c = 0V$

Freq. GHz	S11 dB	S11 °	S12 dB	S12 °	S21 dB	S21 °	S22 dB	S22 °
4	-22.97	169.9	-34.74	25.6	-6.22	-172.9	-9.34	98.1
4.1	-22.15	159	-36.83	7.2	-4.74	-179.4	-8.85	84.5
4.2	-21.67	149.3	-39.2	-7.2	-3.27	172	-8.7	72.1
4.3	-21.35	141.2	-41.02	-21.2	-1.91	162.4	-8.55	60.6
4.4	-21.16	133.9	-42.96	-32.2	-0.62	152	-8.42	49.6
4.5	-21.03	127.4	-44.55	-44.2	0.63	141.2	-8.26	38.7
4.6	-20.94	121.3	-46.11	-54.2	1.84	129.6	-8.04	27.7
4.7	-21	115.9	-47.53	-66.2	3.01	117.4	-7.8	16.4
4.8	-21.08	110.6	-48.79	-77.7	4.12	104.3	-7.56	4.8
4.9	-21.27	106.4	-50.14	-91.6	5.13	90.4	-7.39	-7.3
5	-21.5	102.4	-51.39	-105.3	5.99	75.7	-7.32	-19.6
5.1	-21.8	99.6	-52.81	-121.3	6.67	60.5	-7.43	-31.8
5.2	-22.06	97.1	-54.39	-139.6	7.14	45.1	-7.74	-43.2
5.3	-22.27	95.6	-55.86	-158.3	7.42	30.1	-8.24	-53.6
5.4	-22.47	94.1	-57.39	-177.5	7.55	15.9	-8.88	-62.2
5.5	-22.59	92.9	-58.53	161.5	7.58	2.6	-9.62	-69
5.6	-22.69	91.6	-59.33	140.9	7.57	-10	-10.38	-73.8
5.7	-22.8	90.4	-59.48	119.9	7.58	-21.7	-11.1	-76.7
5.8	-22.9	89	-59.27	101.7	7.62	-32.9	-11.7	-77.5
5.9	-23.14	88	58.76	84.8	7.72	-43.7	-12.14	-76.8
6	-23.38	86.6	-58.03	68.8	7.91	-54.2	-12.31	-74.7
6.1	-23.7	86.9	-57.17	53.3	8.19	-64.9	-12.23	-72.2
6.2	-24.15	87	-56.52	39.9	8.56	-75.9	-11.83	-69.4
6.3	-24.62	89.3	-55.51	27.7	9.02	-87.5	-11.16	-67.3
6.4	-25.03	94.1	-54.47	16	9.55	-100.1	-10.23	-66.4
6.5	-25.04	102.4	-53.41	1	10.1	-114.2	-9.15	-67.5
6.6	-24.31	110.2	-52.5	-14.7	10.6	-129.9	-8.02	-70.8
6.7	-22.84	115.5	-51.5	-30.3	10.89	-147.6	-7.02	-76.5
6.8	-21.18	115.4	-51.21	-50.7	10.83	-166.8	-6.33	-84.2
6.9	-19.83	111	-51.51	-68.5	10.31	173.9	-6.06	-92.3
7	-18.99	105.2	-51.88	-84.2	9.39	155.9	-6.14	-99.7

Typical on Wafer Measurements

Bias Conditions : $V_d = +5V$, $I_d = 330mA$ ($V_g = -1.4V$)

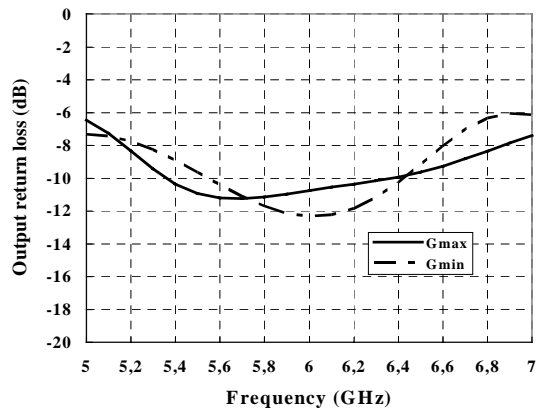
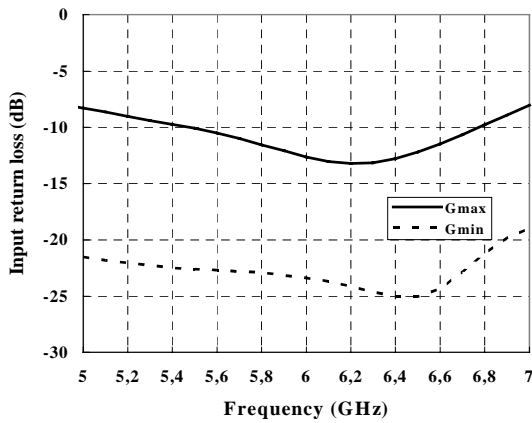
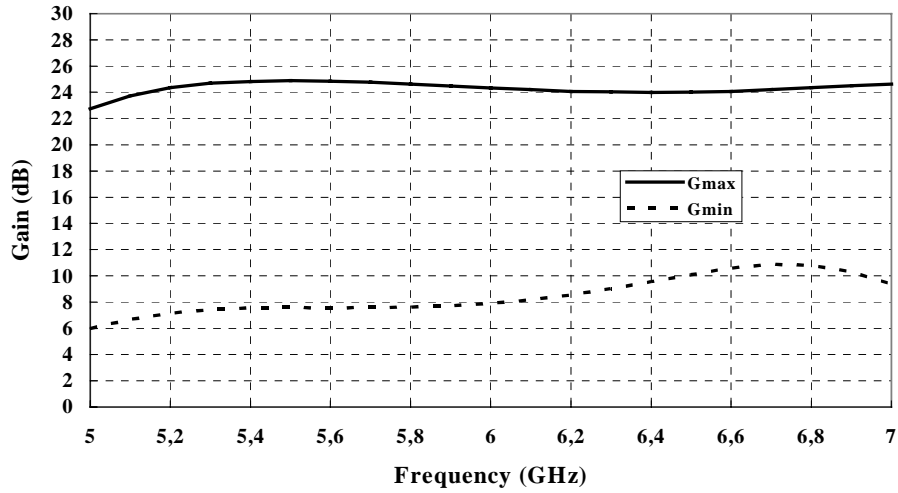

Typical Packaged Device Measurements

1. Output power monitor characteristic

Measurement conditions

Bias : $V_d = +9V$, $I_d = 330mA$ ($V_g = -1.4V$)

Input signal : non-modulated signal,

$F_{in} = 5.8GHz$, $P_{in} = -30dBm$

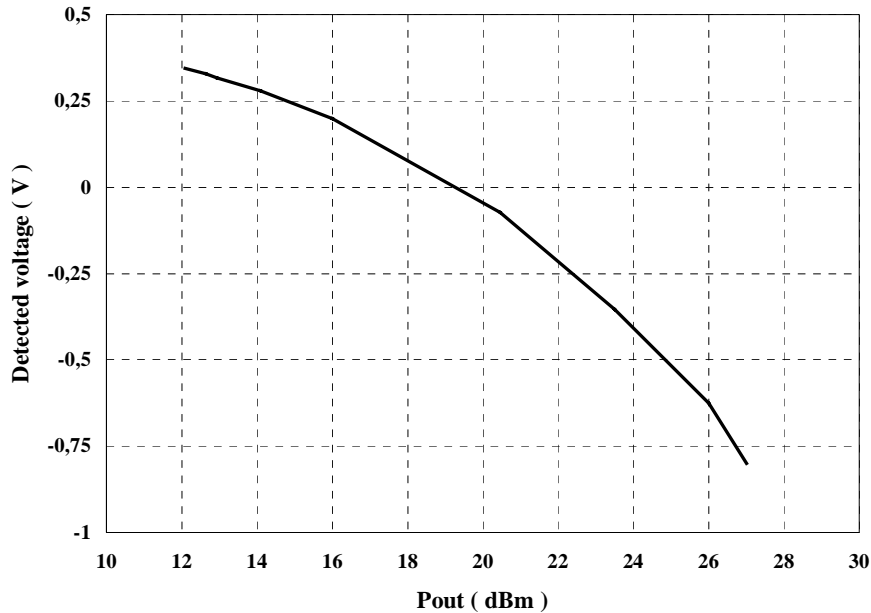

2. Gain control characteristic

Measurement conditions

Bias : $V_d = +9V$, $I_d = 330mA$ ($V_g = -1.4V$)

Input signal : non-modulated signal,

$F_{in} = 5.8GHz$, $P_{in} = -30dBm$

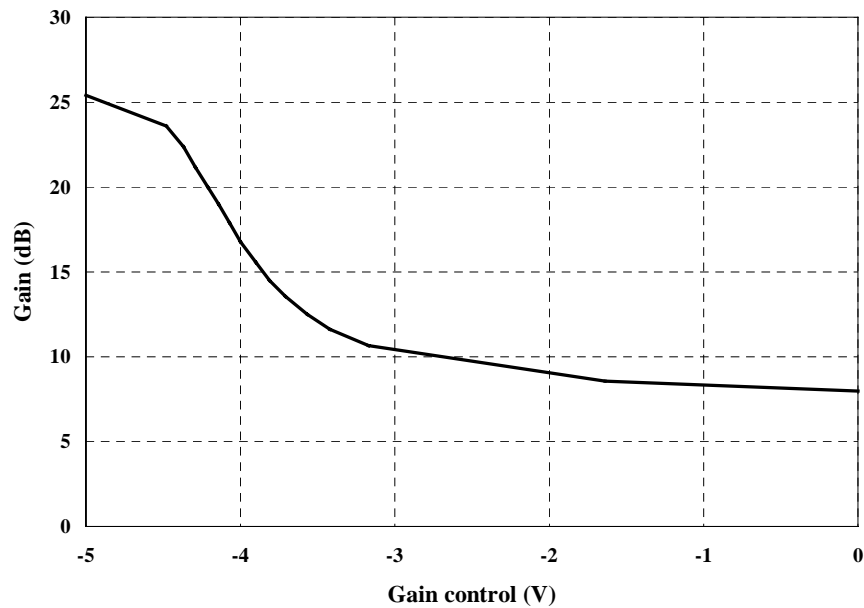

3. Linearity characteristic

Measurement conditions

Bias : $V_d = +9V$, $I_d = 330mA$ ($V_g = -1.4V$)

Input signal : amplitude modulated signal,

$F_{carrier} = F_o = 5.8GHz$, $P_{carrier} = 4.8dBm$

$F_m = 500kHz$, modulation index = 0.7

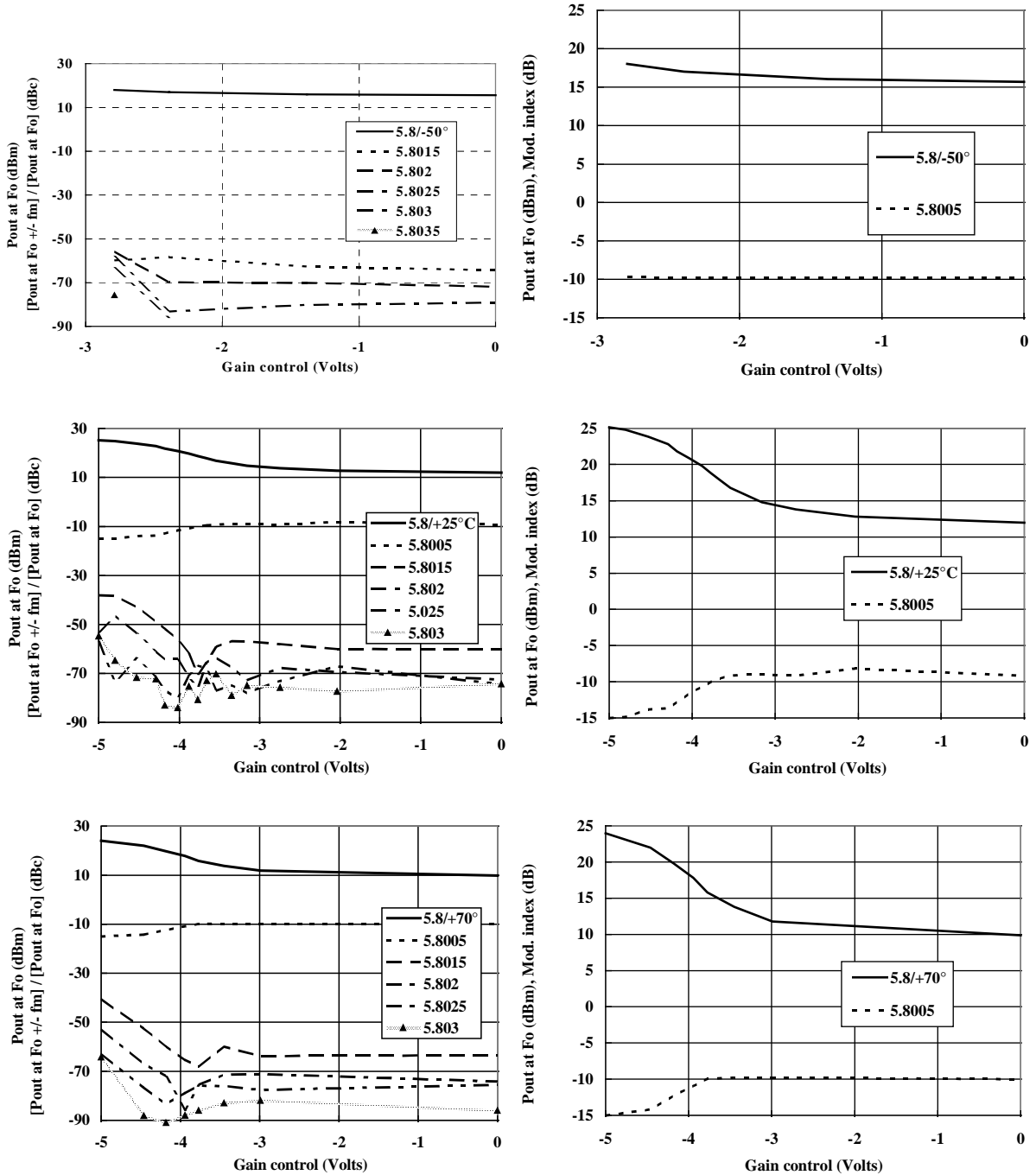

Chip Pad Allocation

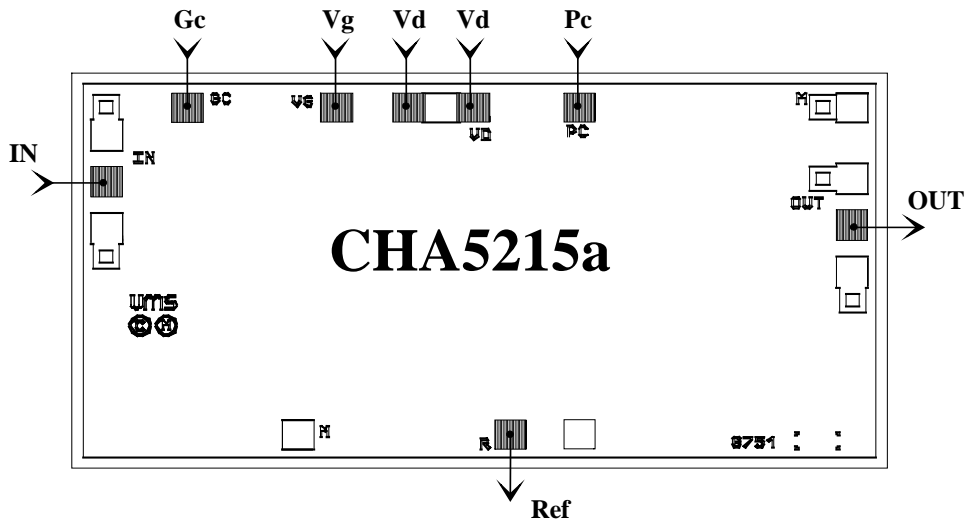

Input And Output Pin References

Pin	Description
IN	RF signal input
Gc	Gain control input
Vg	Negative supply voltage
Vd	Positive supply voltage
Pc	Power monitor output
OUT	RF signal output
Ref	Monitor reference output

Typical Bias Configuration

The typical bias voltage applied to the chip is $V_d = 9V$ and $I_d = 330mA$ ($V_g = -1.4V$)

**Choose V_g in order to have I_d around 330mA. Maximum I_d is 400mA.
Do not apply V_d without V_g .**

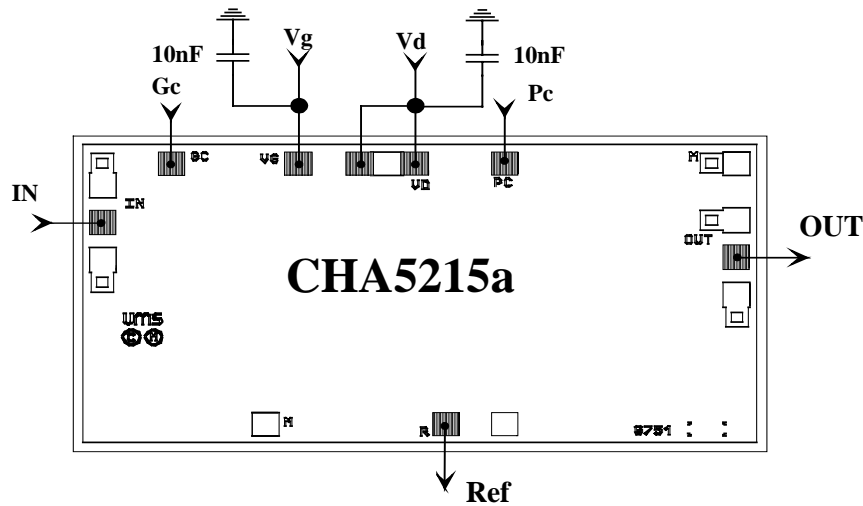

Chip Mechanical Data

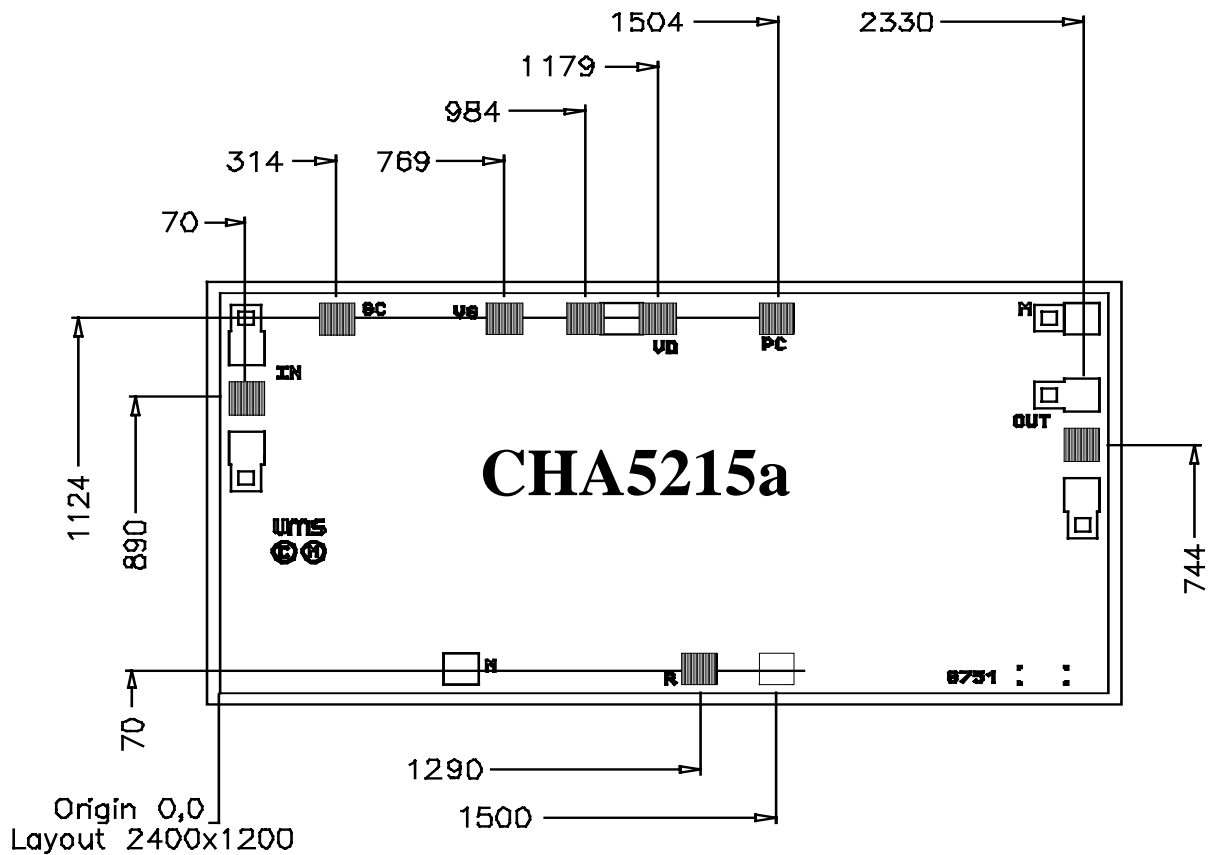

Chip size $2470 \mu m \pm 20 \mu m \times 1270 \mu m \pm 20 \mu m$
Thickness: $100 \mu m \pm 10 \mu m$

Package Mechanical Data (FK)

Unité : mm

Tolérance générale : 0,127

Unit : in

General tolerance : .005

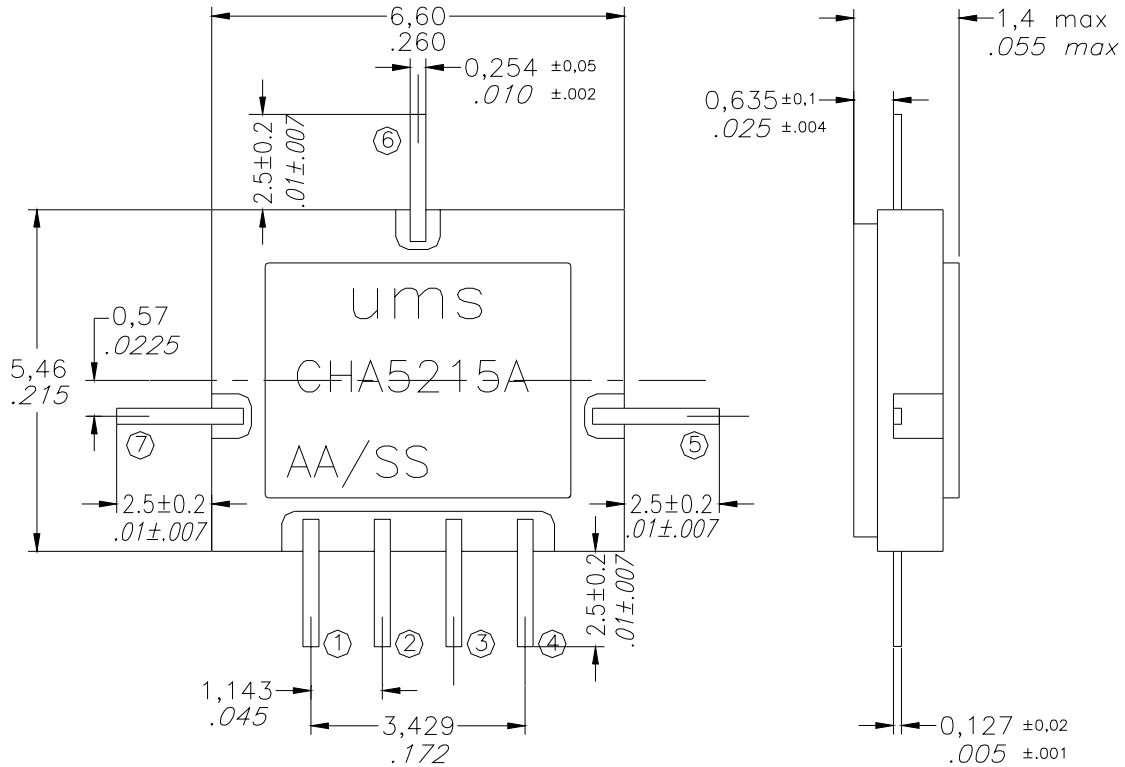

Package Pin Allocation (FK)

1	Pc	Power monitor output
2	Vd	Positive supply voltage
3	Vg	Negative supply voltage
4	Gc	Gain control input
5	IN	RF signal input
6	Ref	Monitor reference output
7	OUT	RF signal output

Ordering Information

Chip form : CHA5215a99F/00
Flatpack package : CHA5215aFKF/23

Information furnished is believed to be accurate and reliable. However **United Monolithic Semiconductors S.A.S.** assumes no responsibility for the consequences of use of such information nor for any infringement of patents or other rights of third parties which may result from its use. No license is granted by implication or otherwise under any patent or patent rights of **United Monolithic Semiconductors S.A.S.**. Specifications mentioned in this publication are subject to change without notice. This publication supersedes and replaces all information previously supplied. **United Monolithic Semiconductors S.A.S.** products are not authorised for use as critical components in life support devices or systems without express written approval from **United Monolithic Semiconductors S.A.S.**