

VICOR CONFIDENTIAL

THIS DOCUMENT AND THE DATA DISCLOSED  
HEREIN OR HEREWITH IS NOT TO BE REPRODUCED,  
USED, OR DISCLOSED IN WHOLE OR IN PART  
TO ANYONE WITHOUT PERMISSION OF VICOR CORP.

REV.	DESCRIPTION	DATE	APPROVED
01	RELSD- E010390	RCM 8/14/01	CFH

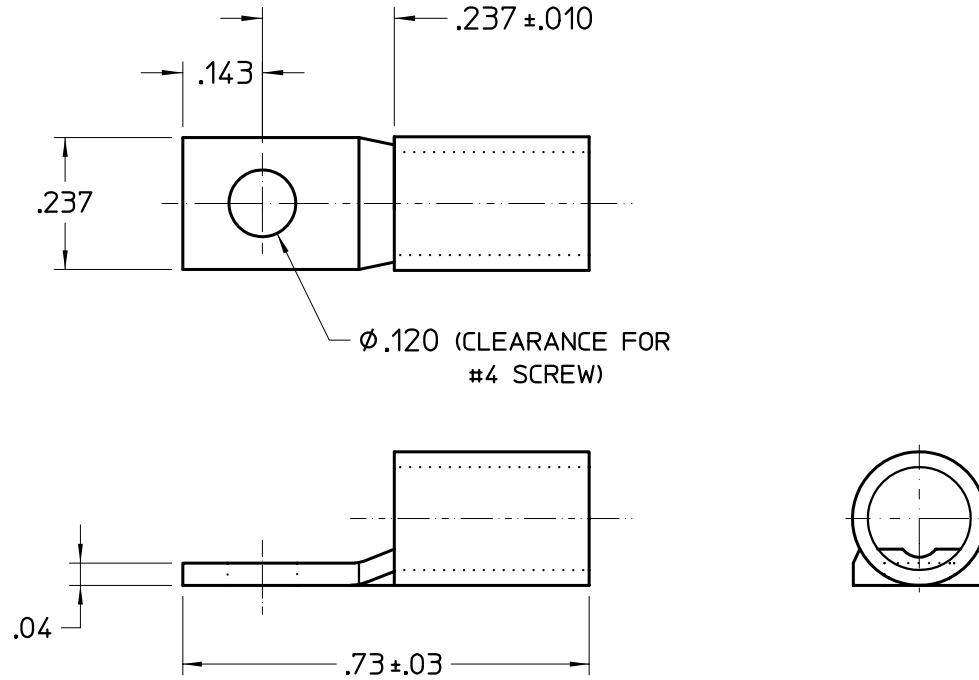

NOTES:

1. MATERIAL: COPPER, ELECTRO-PLATED TIN
2. WIRE RANGE: #12-10 AWG
3. STUD SIZE: FOR #4 SCREW
4. TONGUE MARKED WITH WIRE & STUD SIZE.
5. FOR ADDITIONAL SPECS & DIMENSIONS- CONTACT THE VENDOR & CHECK DATA SHEET.

DRAWN BY <i>P.E.IENI</i>		DATE 1/29/01			
<small>UNLESS OTHERWISE SPECIFIED DIMENSIONS ARE IN INCHES- TOLERANCES ARE: FRACTIONS DECIMALS ANGLES ±1/64 .XX ±.01 °1° .XXX ±.005</small>					
THIRD ANGLE PROJECTION 		SIZE <b>B</b>	FSCM NO. <b>67131</b>	DWG NO <b>23519</b>	REV <b>01</b>
DO NOT SCALE DRAWING		SCALE 4:1	SHEET 1 OF 1		