

FEATURES

- Fault Protected 16-Channel 12-Bit A/D Converter with Sample & Hold, Reference, Clock and 3-state Outputs
- Fast Conversion, less than 15 μ S
- Microprocessor Bus Interface
- 2's Complement Data Output
- Parallel or Serial Data Output Modes
- 65 ns Bus Access Time
- Remote Analog Ground Sensing
- Overvoltage Protected Input (± 50 V over the Supply Voltages)
- Precision Reference for Long Term Stability and Low Gain T.C.
- Guaranteed Linearity Over Temperature
- Guaranteed Performance at +12/-5 V, ± 12 & ± 15 V
- Low Power: 110 mW typ. (7 mW per Channel typ.)
- 32 Channel Version: MP3274

GENERAL DESCRIPTION

The MP3276 is a complete 16-channel, 12-bit Data Acquisition Subsystem with 3-state output buffers for direct interfacing to 16-bit microprocessor buses. Implemented using an advanced BiCMOS process, the converter combines a 16-channel passive overvoltage protected multiplexer instrumentation amp, a sample & hold, a SAR, a 12-bit decoded D/A, a comparator, a precision reference and the control logic to achieve an accurate repeated conversion in less than 15 μ s, and a mux/instrumentation amp settling period of less than 10 μ s.

A unique input design provides input overvoltage protection to ± 50 V over the supply voltages. The circuit design can allow

for an overvoltage condition on unselected channels without disrupting the measured channel or operation of the MP3276! The internal 4 V reference has sufficient output current to provide other system reference needs. Precision thin film scaling and offset resistors are laser trimmed to provide for less than 2 LSB INL for ± 10 V inputs on all channels.

In addition, the MP3276 will output either full scale (0111) for overrange and - full scale (1000....) for underrange conditions. This greatly simplifies microprocessor software development.

SIMPLIFIED BLOCK DIAGRAM

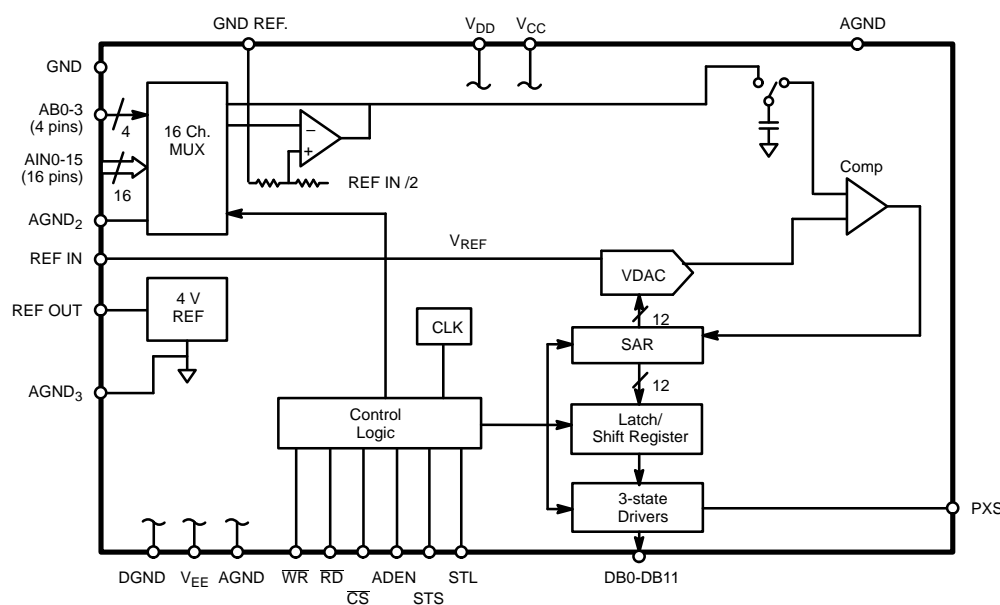

ORDERING INFORMATION

Package Type	Temperature Range	Part No.	DNL (LSB)	INL (LSB)
PGA	-40 to +85°C	MP3276AG	±2	±2
PLCC	-40 to +85°C	MP3276AP	±2	±2

PIN CONFIGURATIONS

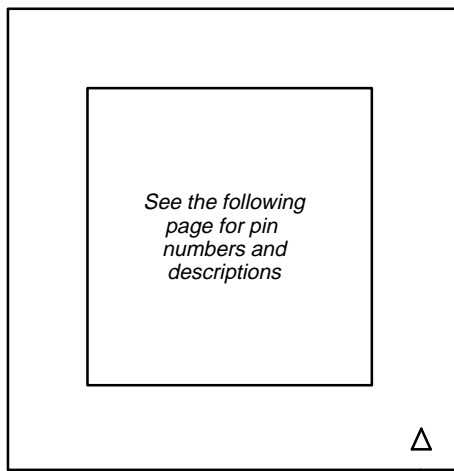

△
↑
Index
Mark

68 Pin PGA
G68

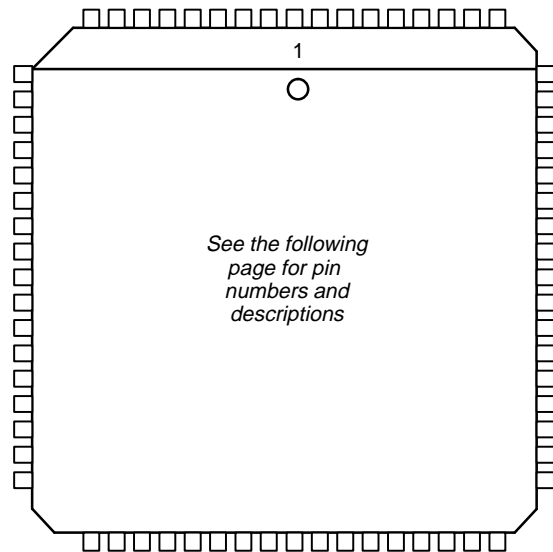

68 Pin PLCC
P68

PIN OUT DEFINITIONS

PLCC PIN NO.	PGA PADS	NAME	DESCRIPTION	PLCC PIN NO.	PGA PADS	NAME	DESCRIPTION
61	1	V _{EE}	Negative Analog Supply	27	35	ADEN	Address Enable
62	2	A _{IN12}	Analog Input 12, AB3-AB0 = 1100	28	36	AB3	Channel Address 3
63	3		N/C or GND	29	37	AB2	Channel Address 2
64	4	A _{IN13}	Analog Input 13, AB3-AB0 = 1101	30	38	AB1	Channel Address 1
65	5		N/C or GND	31	39	AB0	Channel Address 0
66	6	A _{IN14}	Analog Input 14, AB3-AB0 = 1110	32	40	GND	GND
67	7		N/C or GND	33	41	V _{DD}	Positive Digital Supply
68	8	A _{IN15}	Analog Input 15, AB3-AB0 = 1111	34	42	V _{CC}	Positive Analog Supply
1	9		N/C or GND	35	43	A _{IN0}	Analog Input 0, AB3-AB0 = 0000
2	10	GND Ref.	Input Ground Reference	36	44		N/C or GND
3	11	AGND	ADC Analog Ground	37	45	A _{IN1}	Analog Input 1, AB3-AB0 = 0001
4	12	Ref In	Reference Input	38	46		N/C or GND
5	13	Ref Out	Reference Output	39	47	A _{IN2}	Analog Input 2, AB3-AB0 = 0010
6	14	AGND3	Reference Analog Ground	40	48		N/C or GND
7	15	DGND	Digital Ground	41	49	A _{IN3}	Analog Input 3, AB3-AB0 = 0011
8	16	DB0/SDC	Data Output Bit 0/Serial Data Clock	42	50		N/C or GND
9	17	N/C	No Connection	43	51	N/C	No Connection
10	18	DB1	Data Output Bit 1	44	52	A _{IN4}	Analog Input 4, AB3-AB0 = 0100
11	19	DB2	Data Output Bit 2	45	53		N/C or GND
12	20	DB3	Data Output Bit 3	46	54	A _{IN5}	Analog Input 5, AB3-AB0 = 0101
13	21	DB4	Data Output Bit 4	47	55		N/C or GND
14	22	DB5	Data Output Bit 5	48	56	A _{IN6}	Analog Input 6, AB3-AB0 = 0110
15	23	DB6	Data Output Bit 6	49	57		N/C or GND
16	24	DB7	Data Output Bit 7	50	58	A _{IN7}	Analog Input 7, AB3-AB0 = 0111
17	25	DB8	Data Output Bit 8	51	59		N/C or GND
18	26	DB9	Data Output Bit 9	52	60	AGND2	Analog Ground Mux Return
19	27	DB10	Data Output Bit 10	53	61	A _{IN8}	Analog Input 8, AB3-AB0 = 1000
20	28	DB11/SDO	Data Output Bit 11/Serial Data Out	54	62		N/C or GND
21	29	STS	Conversion Status	55	63	A _{IN9}	Analog Input 9, AB3-AB0 = 1001
22	30	STL	Mux Settling Status	56	64		N/C or GND
23	31	PXS	Parallel/XSerial	57	65	A _{IN10}	Analog Input 10, AB3-AB0 = 1010
24	32	\overline{RD}	Read Enable	58	66		N/C or GND
25	33	\overline{CS}	Chip Select	59	67	A _{IN11}	Analog Input 11, AB3-AB0 = 1011
26	34	\overline{WR}	Write Enable	60	68		N/C or GND

ELECTRICAL CHARACTERISTICS TABLE

Unless Otherwise Specified: $V_{DD} = 5\text{ V}$, $V_{CC} = 15\text{ V}$, $V_{EE} = -15\text{ V}$, $GND_{Ref} = 0\text{ V}$, $T_A = 25^\circ\text{C}$,
 $V_{REFIN} = ReOut$

Parameter	Symbol	25°C			Tmin to Tmax		Units	Test Conditions/Comments
		Min	Typ	Max	Min	Max		
Resolution (All Grades)	N	12			12			Bits
KEY FEATURES								
Resolution		12			12		Bits	
Conversion Time, Per Channel	t_{CONVR}	15			15		μs	
ACCURACY (A Grade)¹								
Differential Non-Linearity	DNL	3/4			2		LSB	Refer to Table 6. for output coding
Integral Non-Linearity	INL	1			2		LSB	
Zero Code Error	EZS	2			± 5		LSB	
Full Scale Error	EFS	0.1			± 0.35		%	Best Fit Line (Max INL – Min INL)/2 fff to 000 [hex] transition $V_{REFIN} = 4.000\text{ V}$
POWER SUPPLY REJECTION								
$V_{CC} = 15\text{ V} \pm 1.5\text{ V}$ or $12\text{ V} \pm 0.6\text{ V}$					± 1		LSB	Max change in Full Scale Calibration
$V_{DD} = 5\text{ V} \pm 0.25\text{ V}$					± 2		LSB	
$V_{EE} = -15\text{ V} \pm 1.5\text{ V}$ or $-12\text{ V} \pm 0.6\text{ V}$ or $-5\text{ V} \pm 0.25\text{ V}$					± 1		LSB	
REFERENCE VOLTAGES⁵								
Ref. Voltage Input	Ref In	3.6			4.4		V	$R_{IN} \approx 5\text{ K}\Omega$, $V_{DD} = 5\text{ V}$
Ref. Voltage Output	Ref Out	3.975			4.025		V	
Ref. Source Current		3.0			4.0		mA	
Ref. Sink Current					20		μA	
ANALOG INPUT								
Input Voltage Range ³	V_{IN}	-10			10		V	From \overline{WR} low to high after STL high to low DC
Ground Reference	GND Ref.							
CM Range ²		-3			3		V	
CM RR		TBD					LSB/V	
Input Resistance	R_{IN}	100			130		k Ω	
Input Capacitance ²	C_{IN}				5		pF	
Aperture Delay ²	t_{AP}				180		ns	
Channel-to-Channel Isolation ²		-80			-70		dB	
DIGITAL INPUTS								
\overline{CS} , \overline{WR} , RD AB0-AB4, ADEN, SDC								
Logical "1" Voltage	V_{IH}	2.4			5.5		V	$V_{IN} = GND$ to V_{DD}
Logical "0" Voltage	V_{IL}	-0.5			0.8		V	
Leakage Currents ⁴	I_{IN}	-5			5		μA	
Input Capacitance ²					5		pF	

ELECTRICAL CHARACTERISTICS TABLE (CONT'D)

Description	Symbol	25°C			Tmin to Tmax		Units	Conditions
		Min	Typ	Max	Min	Max		
DIGITAL OUTPUTS (Data Format 2's Complement) DB0/SDC-DB11/SDO, STL, STS								
Logical "1" Voltage	V_{OH}	4.0			2.4		V	$C_{OUT}=15\text{ pF}$ $I_{SOURCE} = 0.5\text{ mA}$ $I_{SINK} = 1.6\text{ mA}$ $V_{OUT}=GND\text{ to }V_{DD}$
Logical "0" Voltage	V_{OL}			0.4		0.4	V	
Tristate Leakage	I_{OZ}	-5		5	-5	5	μA	
POWER SUPPLIES								
Operating Range								Tested at -11.4 and -16.5 only
V_{DD}		+4.5		+5.5	+4.5	+5.5	V	
V_{CC}		+11.4		+16.5	+11.4	+16.5	V	
V_{EE}		-4.75		-16.5	-4.75	-16.5	V	
Operating Current								
I_{DD}			2	7		7	mA	
I_{CC}			5	8		8	mA	
I_{EE}			1.5	3		3	mA	
Power Dissipation			110	200		200	mW	

NOTES

- 1 Tester measures code transitions by dithering the voltage of the analog input (V_{IN}). The difference between the measured and the ideal code width is the DNL error. The INL error is the maximum distance (in LSBs) from the best fit line to any transition voltage Guaranteed. Not tested.
- 2 All channel input pins and ground reference pin have protection which becomes active above $\pm 60\text{ V}$.
- 3 All digital inputs have diodes to V_{DD} and AGND. Input DC currents will not exceed specified limits for any input voltage between GND and V_{DD} .
- 4 Refin should not vary from Refout by more than $\pm 10\%$ of the nominal value of Refout.

Specifications are subject to change without notice

ABSOLUTE MAXIMUM RATINGS ($T_A = +25^\circ\text{C}$ unless otherwise noted)^{1, 2}

V_{CC} to DGND	0 to +16.5 V	REF OUT	Indefinite short to DGND, Momentary short to V_{CC}
V_{EE} to DGND	0 to -16.5 V	Maximum Junction Temperature	150°C
V_{DD} to DGND	0 to +7 V	Package Power Dissipation Rating to 75°C	
AGND to DGND	$\pm 1\text{ V}$	PGA, PLCC	1800 mW
Digital Inputs/Outputs to DGND	-0.5 V to $V_{LOGIC} + 0.5\text{ V}$	Derates above 75°C	25 mW/°C
Analog Inputs ($A_{IN0} - A_{IN31}$, GND REF) to AGND	$\pm 60\text{ V}$	Lead Temperature, Soldering	300°C, 10 Sec
		Storage Temperature (Ceramic)	-65°C to +150°C

NOTES:

- 1 Stresses above those listed under "Absolute Maximum Ratings" may cause permanent damage to the device. This is a stress rating only and functional operation at or above this specification is not implied. Exposure to maximum rating conditions for extended periods may affect device reliability.
- 2 Any input pin which can see a value outside the absolute maximum ratings should be protected by Schottky diode clamps (HP5082-2835) from input pin to the supplies. All logic inputs have protection diodes which will protect the device from short transients outside the supplies of less than 100mA for less than 100 μs .

PRODUCT INFORMATION

Basic Description

The MP3276 is a fault protected data acquisition subsystem available in monolithic form. This product contains all of the circuitry necessary to acquire 16 channels of quasi differential or single-ended analog signals at ± 10 V input range and 15kHz bandwidth. Connections to power, the analog input signals and the digital system are all that is required. The MP3276's input circuitry is protected against active input signals present with the MP3276 power off. This is also the case for any channel exceed-

ing the MP3276 analog input dynamic range without interfering with the channel being digitized. The channel address and channel conversion can be managed in two ways: random channel conversion or same channel conversion. Circuitry on the chip adds a MUX/instrumentation amp settling (STL) delay of 10 μ s max, when a new channel is selected (ADEN = 1). Conversion start is initiated without delay for the single-channel case (ADEN = 0). Data is available in either parallel or serial format.

TIMING

Control and Timing Considerations – Parallel Mode (PXS = 1)

The MP3276 can be operated in the stand-alone mode, with one line for control and everything else hard-wired; or under microprocessor control, where changes can be made dynamically. There are 4 control lines: ADEN, \overline{CS} , \overline{WR} , and \overline{RD} with their functions described in Table 1.

PXS is the control pin for formatting data for serial or parallel control.

\overline{CS}	\overline{WR}	\overline{RD}	ADEN	Data	STL	STS	Comments
ADC Channel Select and Start Convert (See Figure 1. and Table 2.)							
1	X	X	X	—	0	0	No operation
0	↓	1	0	Hi-Z	0	0	No operation if ADEN = 0
0	↓	1	1	Hi-Z	↑	0	Input MUX channel selected, STL set on \overline{WR} falling edge
0	0	1	X	Hi-Z	1	0	MUX select disabled
0	↑	1	X	Hi-Z	0	↑	Start convert on \overline{WR} rising edge
0	1	1	X	Hi-Z	↓	↑	Start convert on STL falling edge
0	1	1	X	Hi-Z	0	↓	STS goes low at end of conversion
Read ADC Data – Parallel Output Mode (PXS = 1) (See Figure 2. and Table 3.)							
0	1	↓	X	—	0	0	Data outputs enabled
0	X	0	X	ADC	0	0	Data from previous conversion on data bus
0	X	↑	X	Hi-Z	0	0	Data outputs disabled
0	1	X	X	Hi-Z	0	1	Data/ \overline{RD} disabled while STS high
0	X	0	X	Last ADC	1	0	Data from last conversion on data bus
0	⌋	0	0	Hi-Z	0	↑	STL, MUX select disabled with ADEN = 0, data outputs disabled on STS rising edge
0	⌋	0	X	ADC	0	↓	New data appears on data bus on falling edge of STS

Note 1: If $\overline{RD} = 1$, data outputs remain high impedance. It is recommended that \overline{RD} will not change during a conversion in order to reduce noise. It is further recommended that $\overline{RD} = 1$ during conversion to reject any noise present on the data bus.

Table 1. Logic Truth Table for PXS = 1 (Parallel Mode)

The MP3276 is easily interfaced to a wide variety of microprocessors and other digital systems. Discussion of the timing requirements of the MP3276 control signals follows.

Figure 1. shows a complete timing diagram for the MP3276 convert start operation.

Either \overline{WR} or \overline{CS} may be used to initiate a conversion. We recommend using \overline{WR} as used in Figure 1. It is quieter and has less propagation delay than \overline{CS} . If \overline{CS} is used to trigger the conversion the specified set-up times will be longer.

A conversion is started by taking \overline{WR} low, then high again (conversion is enabled on the rising edge of \overline{WR}). There are two possible conditions that will affect conversion timing.

1. ADEN = 1. At the falling edge of \overline{WR} , the input channel is determined by the data present on the address bits. The track and hold begins to settle after which STL returns low, indicating that the multiplexer and the buffer amp have settled to less than 1/2 LSB of final value. If the rising edge of \overline{WR} returns high prior to STL going low, conversion will begin on the falling edge of STL. If the rising edge of \overline{WR} is delayed until after STL returns low, the input signal is sampled and the conversion is started at the rising edge of \overline{WR} giving the user better control of the sampling time.

2. ADEN = 0. At the falling edge of \overline{WR} the data present at the address is ignored and the channel selected during the previous conversion remains selected. In this case the track and hold settling time is omitted and STL never goes high. At the rising edge of \overline{WR} the input signal is sampled, and conversion is started.

There are two possible states that the data outputs could be in during a conversion.

1. If \overline{RD} is held high during a conversion the outputs would remain high impedance throughout the conversion. This is the preferred method of operation as any noise present on the data bus is rejected.
2. If \overline{RD} and \overline{CS} are held low during a conversion, the data present will be from the previous conversion until the present conversion is completed when STS returns low. The data from the new conversion will appear on the outputs. The state of \overline{RD} or \overline{CS} should not change during a conversion.

Once a conversion is started and the STL or STS line goes high, convert start commands will be ignored until the conversion cycle is completed. The output data buffers cannot be enabled during conversion. In addition, all inputs and outputs which change during conversion can introduce noise, and should be avoided when possible.

ADC Write Timing	Time Interval	25°C	Tmin to Tmax	Limits	Comments/Test Conditions
ADC Control Timing					
\overline{CS} to \overline{WR} Set-Up Time	t ₁	0	0	ns min	
\overline{CS} to \overline{WR} Hold Time	t ₂	0	0	ns min	
Address to \overline{WR} Set-Up Time	t ₃	0	0	ns min	
Address to \overline{WR} Hold Time	t ₄	0	0	ns min	
\overline{WR} Pulse Width	t ₅	80	80	ns min	
ADEN to \overline{WR} Set-Up Time	t ₆		0	ns min	
ADC Conversion Timing					
\overline{WR} to STL Delay	t ₇	150	150	ns max	Load ckt of Figure 5, C _L = 20 pF, ADEN = 1
STL High (mux/amp settle)	t ₈	10	15	µs max	Load ckt of Figure 5, C _L = 20 pF
STL to STS Low (Converting)	t ₉	15	20	µs max	Load ckt of Figure 5, C _L = 20 pF
\overline{WR} to STS High (ADEN = 0)	t ₁₂	200	250	ns max	STL = 0 when ADEN = 0
\overline{WR} to STS Low (ADEN = 1)	t ₁₀	15	20	µs max	
STS High to Bus Relinquish Time	t ₁₃	150	150	ns max	Load ckt of Figure 4
STS Low to Data Valid (\overline{RD} = 0)	t ₁₄	50	50	ns max	Load ckt of Figure 3, C _L = 20 pF

Table 2. ADC Write Timing
(See Figure 1.)

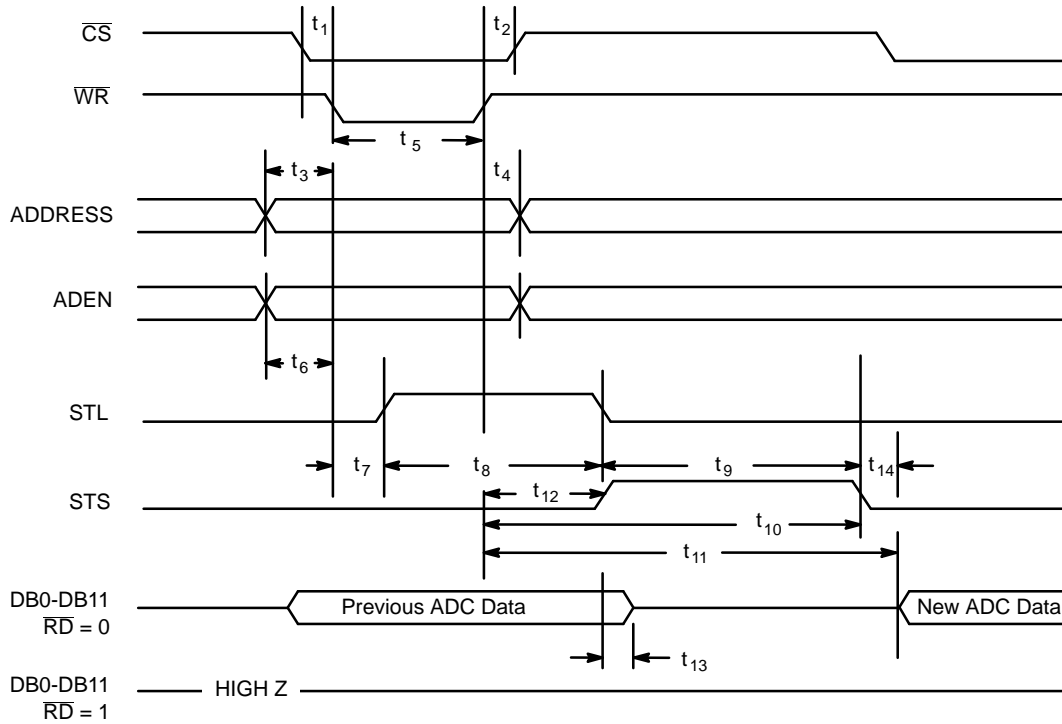

Figure 1. Timing for ADC Channel Select Start Conversion

ADC Read Timing	Time Interval	25°C	Tmin to Tmax	Limits	Comments/Test Conditions
\overline{CS} to \overline{RD} Set-Up Time	t_{15}	0	0	ns min	Load ckt of Figure 3., $C_L = 20$ pF Load ckt of Figure 3., $C_L = 100$ pF
\overline{CS} to \overline{RD} Hold Time	t_{16}	0	0	ns min	
\overline{RD} to Data Valid Delay	t_{17}	100	150	ns max	
Bus Relinquish Time after \overline{RD} High	t_{18}	100	150	ns max	Load ckt of Figure 4.
\overline{RD} Pulse Width	t_{19}	100	150	ns min	Load ckt 4

Table 3. ADC Read Timing
(See Figure 2.)

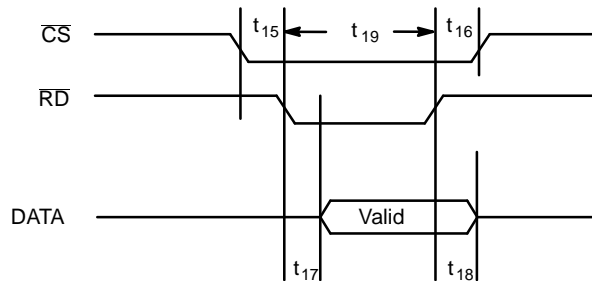

Figure 2. Timing for ADC Read

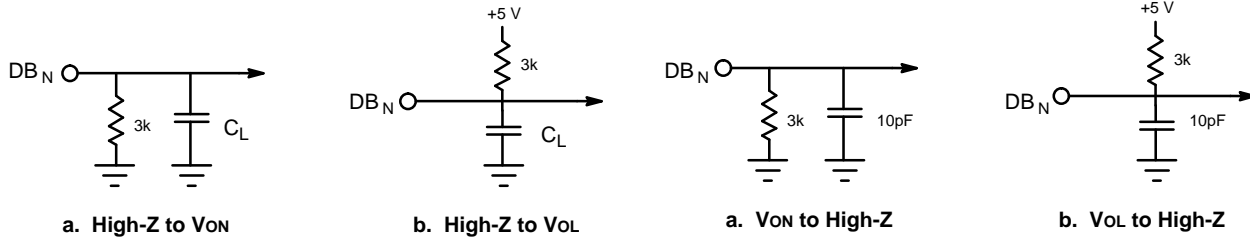

Figure 3. Load Circuit for Data Access Time Test

Figure 4. Load Circuit for Bus Relinquish Time Test

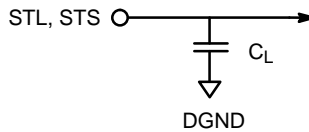

Figure 5. Load Circuit for \overline{WR} to STS Delay

Serial Data Output Mode (PXS = 0)

The MP3276 output data is available in serial form when PXS = 0 prior to the \overline{RD} high-to-low transition. When PXS = 0, the DB11/SDO pin functions as the serial data output. The DB0/SDC pin functions as the serial clock input and all other data outputs are 3-stated.

The serial data output sequence is MSB (DB11) first to LSB (DB0) last. The MSB (DB11) data bit appears at DB11/SDO when STS goes low. The second most significant bit appears at DB11/SDO on the next DB0/SDC high-to-low transition. The LSB (DB0) is present at DB11/SDO on the 11th SDC high-to-low transition.

The control pin functions (ADEN, \overline{CS} , \overline{WR} , and \overline{RD}) are the same as the parallel mode of operation. Further information regarding serial control and timing is shown in *Figure 6.*, *Table 4.* and *Table 5.*

For a minimum interconnect serial environment, the channel address state can be generated in at least two ways, using an address counter, or using an address serial to parallel converter. \overline{WR} can then be used as the counter clock or shift register load signal as well as the A/D converter start convert signal on the rising edge. (Note that the falling edge loads the address present at the address port.)

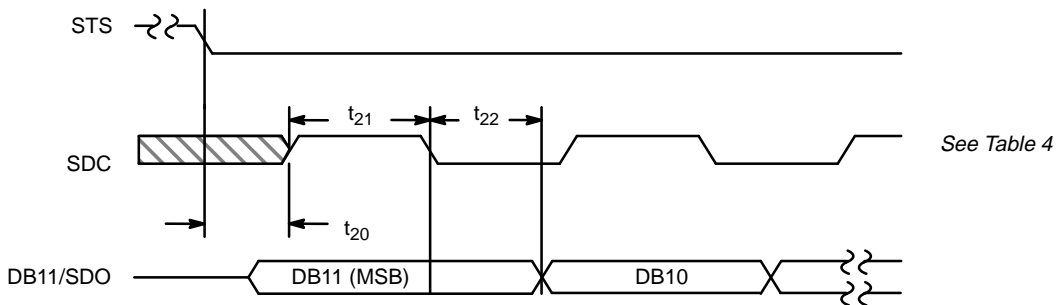

SDC should be in a high state during the STS high period. SDC can make the first high to low transition after t₂₁. In normal use it is assumed that PXS is hardwired low. However, if the mode of operation is changed, PXS must go low prior to \overline{RD} going low.

Figure 6. Serial Data Mode Timing

Serial Data Output Timing	Time Interval	25°C	Tmin to Tmax	Limits	Comments/Test Conditions
STS low to SDO (DB11) Valid, RD = 0 Minimum clock high pulse width SDC low to data valid delay	t ₂₀	50	50	ns max	Load Ckt 4 of Figure 3.
	t ₂₁	50	80	ns max	Load ckt of Figure 3., C _L = 20pF Load ckt of Figure 3., C _L = 100pF
	t ₂₂	150	200	ns max	
		200	250	ns max	

Table 4. Serial Data Output Mode Timing (See Figure 6.)

CS	PXS	WR	RD	ADEN	Data	STL	STS	DB0/SDC	Comments
ADC Channel Select and Start Convert									
1	X	X	X	X	—	0	0	X	No Operation
0	↓	X	1	X	Hi-Z	0	0	X	Serial mode enabled (1)
0	0	↓	1	0	Hi-Z	0	0	X	No operation if ADEN = 0
0	0	↓	1	1	Hi-Z	↑	0	X	Input MUX channel selected, STL set on falling edge of WR
0	0	0	1	X	Hi-Z	1	0	X	MUX select disabled
0	0	↑	1	X	Hi-Z	0	↑	X	Start convert on WR rising edge
0	0	1	1	X	Hi-Z	↓	↑	X	Start convert on STL falling edge
0	0	1	1	X	Hi-Z	0	↓	X	STS goes low at end of conversion
Read ADC Data (See Table 4. and Figure 6.)									
0	0	1	↓	X	—	0	0	1	Serial output (DB11/SDO) and serial clock input (DB0/SDC) enabled
0	0	X	X	X	MSB (DB11)	0	0	1	MSB data available at DB11/SDO
0	0	X	0	X	DB10	0	0	↓	Next significant bit shifted out to DB11/SDO
0	0	X	0	X	DB10	0	0	0	No Operation
0	0	X	0	X	DB10	0	0	↑	No Operation
0	0	X	0	X	DB9	0	0	↓	Next significant bit shifted out to DB11/SDO
0	0	X	↑	X	Hi-Z	0	0	X	Data outputs/SDC input disabled
0	X	1	X	X	Hi-Z	0	1	X	Data outputs/RD disabled when STS = 1
0	X	⌋	0	0	Hi-Z	0	↑	1	STL, MUX select disabled when ADEN = 0
0	0	⌋	0	X	MSB (DB11)	0	↓	1	New data appears at DB11/SDO on falling edge of STS

Note 1: If RD = 1, data outputs remain high impedance. It is recommended that RD will not change during a conversion in order to reduce noise. It is further recommended that RD = 1 during conversion to reject any noise present on the data bus.

Table 5. Logic Truth Table – Serial Data Output Mode

2's Complement Output Code (Hexidecimal)						Ideal Transition Voltage
0111	1111	1110 (7fe) to	0111	1111	1111 (7ff)	+FS – 1 1/2 LSB
0000	0000	0000 (000) to	0000	0000	0001 (001)	0 V +1/2 LSB
1111	1111	1111 (fff) to	0000	0000	0000 (000)	0 V –1/2 LSB
1000	0000	0000(800) to	1000	0000	0001 (801)	–FS +1/2 LSB

Table 6. Key Output Codes vs. Input Voltage (2's Complement Code)

APPLICATION INFORMATION

The MP3276 is a complete A/D converter system, with its own built-in reference and clock. It may be used by itself (“stand-alone” operation), or it may be interfaced with a microprocessor which can control both conversion and formatting of output.

Successful application of the MP3276 requires careful attention to four main areas:

- 1) Physical layout.
- 2) Connection/Trimming according to mode of operation.
- 3) Conditioning of input signals.
- 4) Control and Timing considerations.

Physical Layout

The 12-bit accuracy of the MP3276 represents a dynamic range of 72dB. Precautions must be taken to avoid any interfering signals, whether conducted or radiated, to assure that this is not degraded.

- Avoid placing the chip and its analog signals near logic traces. In general, using a double sided printed circuit card with a good ground plane on the component side is recommended. Routing analog signals between ground traces will help isolate digital control logic. If these lines cross, do so at right angles. The GND Ref. is the positive terminal of the MUX/Instrumentation amplifier and will provide common mode noise rejection. It should be close to and shielded together with the channel inputs in order to take advantage of this feature.
- Power supplies should be quiet and well regulated. Grounds should be tied together at the package and back to the system ground with a single path. Bypass the supplies at the device with a 0.01 to 0.1µF ceramic cap and a 10-47 µF tantalum type, in parallel.

“Stand-Alone” Operation

The MP3276 can be used in “stand-alone” operation, which is useful in systems not requiring full computer bus interface capability. This operation is available for either parallel or serial mode.

For this operation, $\overline{CS} = 0$, ADEN = 1, and conversion is controlled by \overline{WR} . The 3-state buffers are enabled when \overline{RD} goes low. There are two possible conditions that the 3-state buffers could be in during a conversion. If \overline{RD} goes low prior to \overline{WR} , the output buffers are enabled and the data from the previous conversion is available at the outputs during STL = 1. At the end of the present conversion which is initiated at the rising edge of \overline{WR} , STS returns low and the new conversion result is placed on the output data buffers.

If \overline{WR} goes low prior to \overline{RD} , the data buffers remain in a high impedance state and conversion is initiated at the rising edge of \overline{WR} . Upon the end of the conversion the STS returns low and the conversion result is placed on the output data buffers. It is

imperative that \overline{RD} or \overline{WR} not change during a conversion to insure that errors will not occur.

Ground Reference

The ground reference pin can be used for remote ground sensing of a common mode input signal with a maximum 6 V p-p around AGND.

This common input can also be used to dither each input’s “zero”. By averaging multiple conversions digitally, higher resolution for each input conversion can be obtained. Patterns for this dither can be a ramp, a stair step, or white noise.

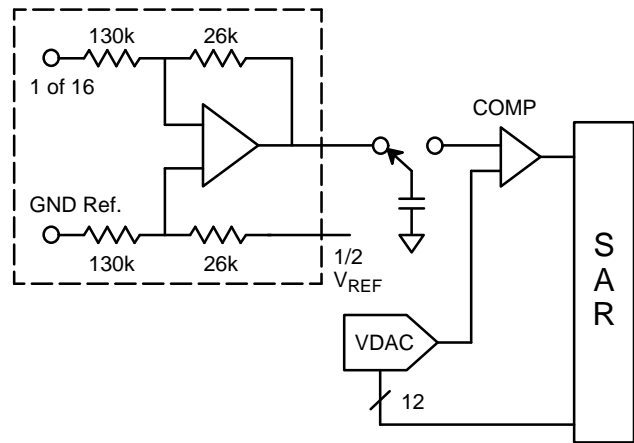

Figure 7. Equivalent Input Circuit

Quasi Differential Sampling

Method 1

For remote ground sensing where the remote ground does not change more than ±3 V from the A/D ground, connect GND Ref to the remote ground.

Method 2

Where Method 1 applies to each channel or group of channels, add a mux to allow connecting the appropriate ground to GND Ref.

Method 3

Use two parts. Tie both GND Ref pins together and connect this node to the “common” remote GND. Control the sample point by connecting each STL through an “OR” gate whose output is “NAND” connect with \overline{WR} (inverted \overline{WR}). Use this output as \overline{WR} to both \overline{WR} inputs. By controlling the \overline{WR} , sample delay differences between the two converters is minimized. Two parts from the same date code will further minimize this difference. Treat one A/D as the (+) terminal and the other as the (–) terminal of the differential signal. Now the difference can be taken digitally.

68 LEAD PLASTIC LEADED CHIP CARRIER (PLCC) P68

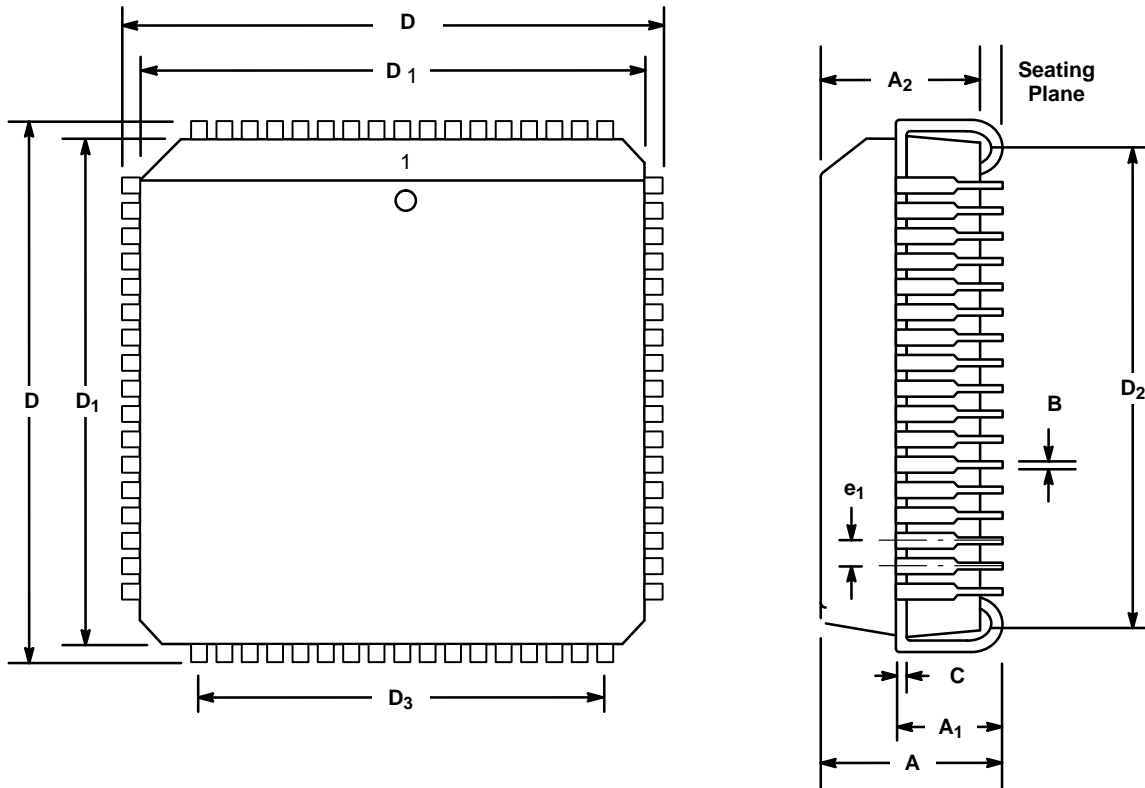

SYMBOL	INCHES		MILLIMETERS	
	MIN	MAX	MIN	MAX
A	.165	.180	4.19	4.57
A ₁	.095	.118	2.51	3.00
A ₂	0.146	0.154	3.71	3.91
B	0.013	0.021	0.330	0.553
C	0.097	0.0103	0.246	0.261
D	.985	.995	25.02	25.27
D ₁ (1)	.950	.954	24.13	24.23
D ₂	.890	.930	22.60	23.62
D ₃	0.800 Ref		20.32 Ref.	
e ₁	0.050 BSC		1.27 BSC	

Note: (1) Dimension D₁ does not include mold protrusion.
Allowed mold protrusion is 0.254 mm/0.010 in.

**68 LEAD PIN GRID ARRAY
(PGA)
G68**

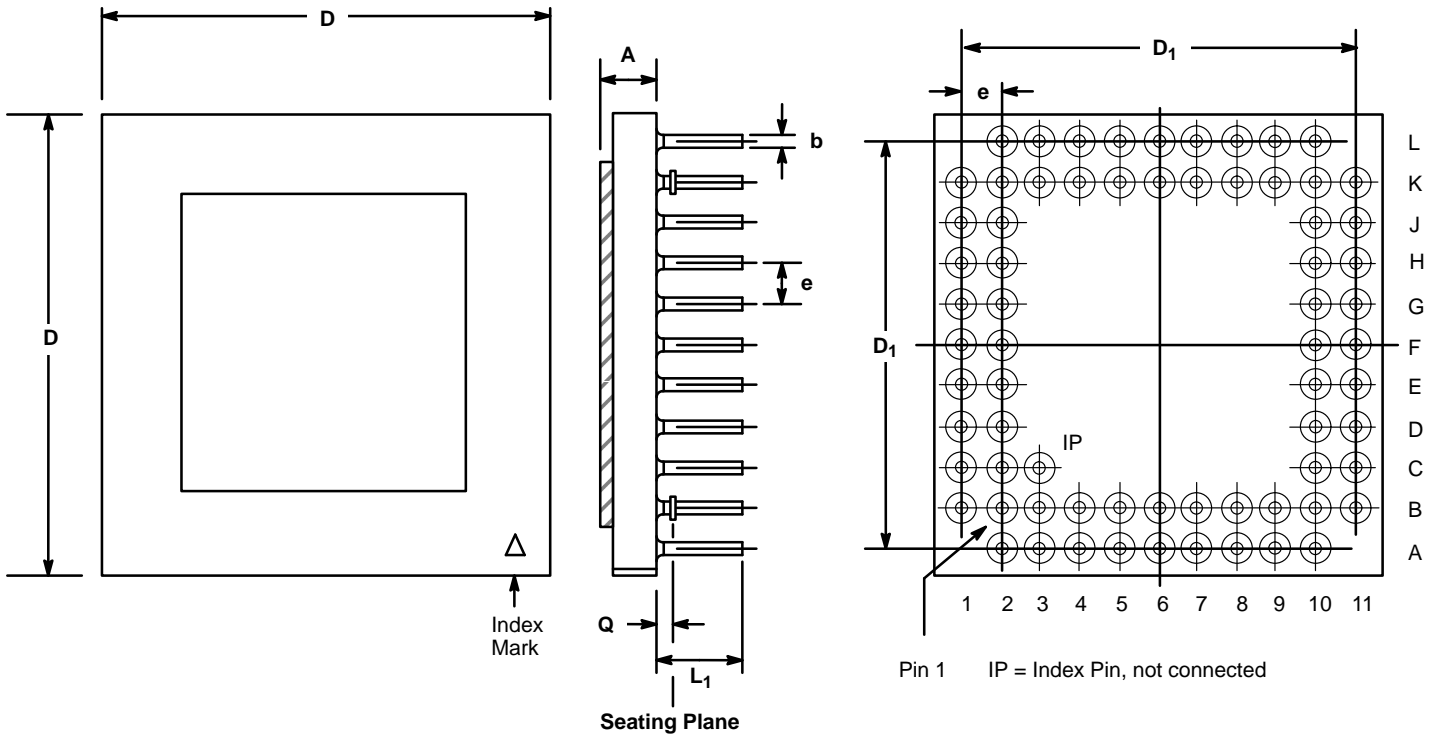

SYMBOL	INCHES		MILLIMETERS	
	MIN	MAX	MIN	MAX
A	0.079	0.095	2.00	2.41
b	0.016	0.020	0.406	0.508
D	1.086	1.110	27.6	28.2
D_1	0.788	0.812	20.0	20.6
e	0.100 typ.		2.54 typ.	
L_1	0.170	0.190	4.32	4.83
Q	0.050 typ.		1.27 typ.	

CONNECTION TABLE							
PAD	PIN	PAD	PIN	PAD	PIN	PAD	PIN
1	B2	18	K2	35	K10	52	B10
2	B1	19	L2	36	K11	53	A10
3	C2	20	K3	37	J10	54	B9
4	C1	21	L3	38	J11	55	A9
5	D2	22	K4	39	H10	56	B8
6	D1	23	L4	40	H11	57	A8
7	E2	24	K5	41	G10	58	B7
8	E1	25	L5	42	G11	59	A7
9	F2	26	K6	43	F10	60	B6
10	F1	27	L6	44	F11	61	A6
11	G2	28	K7	45	E10	62	B5
12	G1	29	L7	46	E11	63	A5
13	H2	30	K8	47	D10	64	B4
14	H1	31	L8	48	D11	65	A4
15	J2	32	K9	49	C10	66	B3
16	J1	33	L9	50	C11	67	A3
17	K1	34	L10	51	B11	68	A2

Note: The letters A-H and numbers 1-8 are the coordinates of a grid. For example, pin 1 is at the intersections of the "B" vertical line and the "2" horizontal line.

Notes

Notes

NOTICE

EXAR Corporation reserves the right to make changes to the products contained in this publication in order to improve design, performance or reliability. EXAR Corporation assumes no responsibility for the use of any circuits described herein, conveys no license under any patent or other right, and makes no representation that the circuits are free of patent infringement. Charts and schedules contains here in are only for illustration purposes and may vary depending upon a user's specific application. While the information in this publication has been carefully checked; no responsibility, however, is assumed for inaccuracies.

EXAR Corporation does not recommend the use of any of its products in life support applications where the failure or malfunction of the product can reasonably be expected to cause failure of the life support system or to significantly affect its safety or effectiveness. Products are not authorized for use in such applications unless EXAR Corporation receives, in writing, assurances to its satisfaction that: (a) the risk of injury or damage has been minimized; (b) the user assumes all such risks; (c) potential liability of EXAR Corporation is adequately protected under the circumstances.

Copyright 1994 EXAR Corporation

Datasheet April 1995

Reproduction, in part or whole, without the prior written consent of EXAR Corporation is prohibited.