

ELECTRICAL SPECIFICATIONS:

- 1.0 TURNS RATIO: $(P4-P5-P6) : (J3-J6)$: 1CT : 1CT ± 3%
 $(P3-P2-P1) : (J1-J2)$: 1CT : 1CT ± 3%
- 2.0 INDUCTANCE: $(J3-J6)$: 350uH MIN. @ 0.1V, 100KHz, 8mA DC Bias
 $(P3-P1)$: 350uH MIN. @ 0.1V, 100KHz, 8mA DC Bias
- 3.0 LEAKAGE INDUCTANCE: $P6-P5-P4$ (WITH J6 AND J3 SHORT) : 0.3 MAX. @ 1MHz
 $P3-P2-P1$ (WITH J2 AND J1 SHORT) : 0.3 MAX. @ 1MHz
- 4.0 INTERWINDING CAPACITANCE: $(P6,P5,P4)$ TO $(J6,J3)$: 30pf MAX @ 1MHz
 $(P3,P2,P1)$ TO $(J2,J1)$: 30pf MAX. @ 1MHz
- 5.0 DC RESISTANCE: $(J6-J3)=(J2-J1)$: 1.2 ohms Max.

NOTES

1.0 PINS WITHOUT ELECTRICAL CONNECTION ARE OMITTED.

Bel Stewart Connector
 11118 Susquehanna Trail, South
 Glen Rock, Pa 17327-9199
 717.234.7512

MagJack

<http://www.stewartconnector.com>

THIS DRAWING AND THE SUBJECT MATTER SHOWN THEREON ARE CONFIDENTIAL AND PROPERTY OF BEL STEWART CONNECTOR AND SHALL NOT BE REPRODUCED, COPIED, OR USED IN ANY MANNER WITHOUT PRIOR WRITTEN CONTENT OF BEL STEWART CONNECTOR. THE SUBJECT MATTER MAY BE PATENTED OR A PATENT MAY BE PENDING.

SHEET
1 OF 4

DRAWING NO.

SI-50146 REV. 04

RECEIVE

- 6.0 RETURN LOSS: (J3-J6)=100 OHMS AND (P1-P3)=100 OHM REF.
1MHz TO 30MHz : 18dB MIN.
30MHz TO 80MHz : 12dB MIN.
NOTE: 100 OHMS CONNECTED TO (J2-J1) OR (P6-P4).
- 7.0 DIELECTRIC WITHSTAND: (J1, J2) TO (P1, P3) : 1500 VAC
(J3, J6) TO (P4,P6) : 1500 VAC
- 8.0 INSERTION LOSS: RS=RL=100 ohms : 1.1 dB TYP
100KHz TO 100MHz
- 9.0 RISE TIME: RS=100 OHMS AND RL = 100 OHMS : 3.0 nS MAX
OUTPUT VOLTAGE = 1 V peak : 3.0 nS MAX
PULSE WIDTH= 112nS
- 10.0 CROSS TALK: 1-100 MHz : 30 dB TYP
- 11.0 COMMON TO COMMON MODE ATTENUATION: 1MHz TO 100MHz : 35dB TYP

Bel Stewart Connector
11118 Susquehanna Trail, South
Glen Rock, Pa 17327-9199
717.234.7512

MagJack[®]

<http://www.stewartconnector.com>

THIS DRAWING AND THE SUBJECT MATTER SHOWN THEREON ARE CONFIDENTIAL AND PROPERTY OF BEL STEWART CONNECTOR AND SHALL NOT BE REPRODUCED, COPIED, OR USED IN ANY MANNER WITHOUT PRIOR WRITTEN CONTENT OF BEL STEWART CONNECTOR. THE SUBJECT MATTER MAY BE PATENTED OR A PATENT MAY BE PENDING.

SHEET
2 OF 4

DRAWING NO.

SI-50146 REV. 04

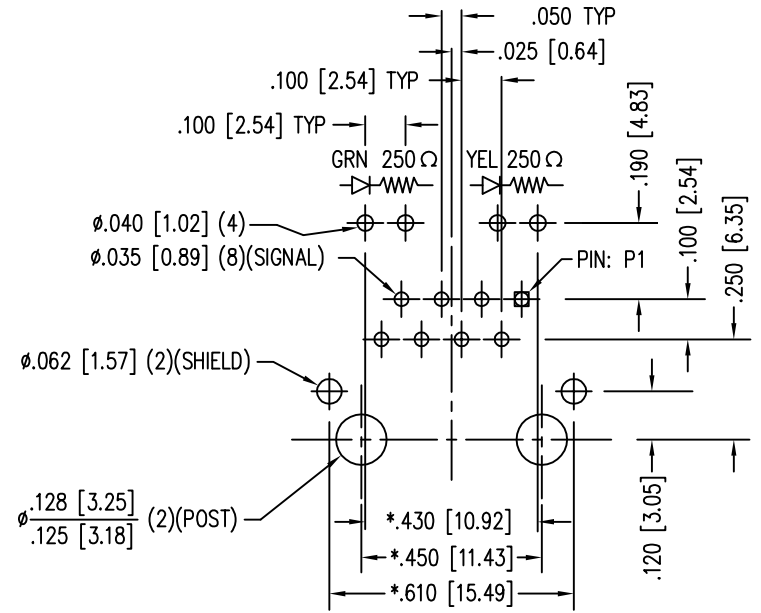
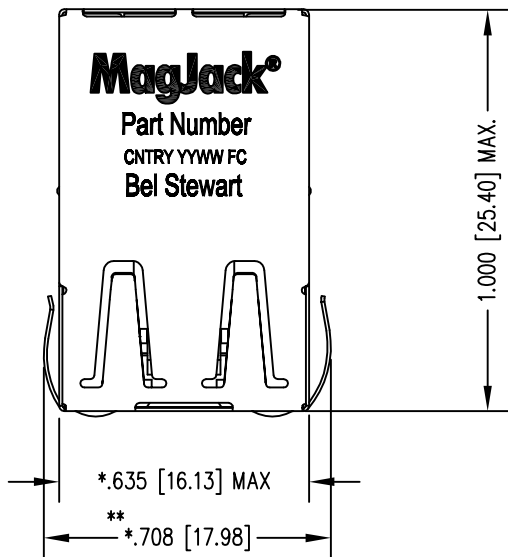

P.C.B. RECOMMENDED HOLE LAYOUT
 SEEN FROM COMPONENT SIDE
 TOLERANCE $\pm .003 [0.08]$ UNLESS OTHERWISE SPECIFIED

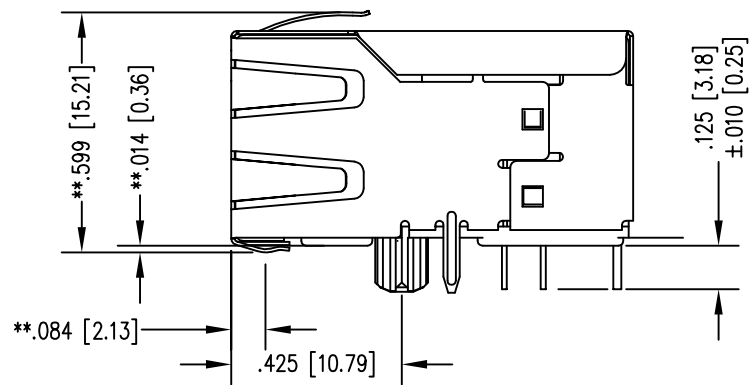
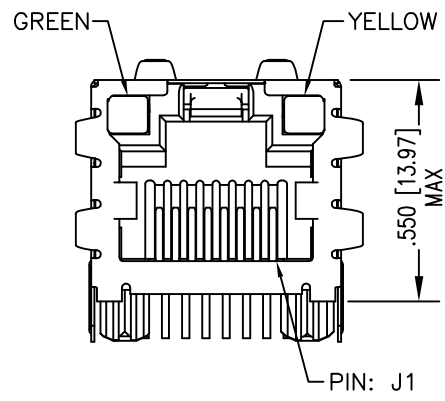

- NOTES:
- TOLERANCES COMPLY WITH F.C.C. DIMENSION REQUIREMENTS
 - DIMENSIONS SHOWN WITH "*" TO BE CENTRAL ABOUT CENTER LINE
 - DIMENSIONS SHOWN ARE SUBJECT TO CHANGE WITHOUT NOTICE.
 - PIN NOT ELECTRICALLY CONNECTED MAYBE OMITTED. SEE ELECTRICAL DRAWING FOR OMITTED PINS.
 - STANDARD 50 MICRO-INCH SELECTIVE GOLD PLATING
 - REFLOW COMPATIBLE - 230°C/90 SEC.
 - ALL POLYMERS FLAMMABILITY - UL94V0

MI50005/24-0266 X

THIS DRAWING AND THE SUBJECT MATTER SHOWN THEREON ARE CONFIDENTIAL AND PROPERTY OF BEL STEWART CONNECTOR AND SHALL NOT BE REPRODUCED, COPIED, OR USED IN ANY MANNER WITHOUT PRIOR WRITTEN CONTENT OF BEL STEWART CONNECTOR. THE SUBJECT MATTER MAY BE PATENTED OR A PATENT MAY BE PENDING.

Bel Stewart Connector 11118 Susquehanna Trail, South Glen Rock, Pa 17327-9199 717.234.7512		 http://www.stewartconnector.com
SHEET 3 OF 4	DRAWING NO. SI-50146	REV. 01

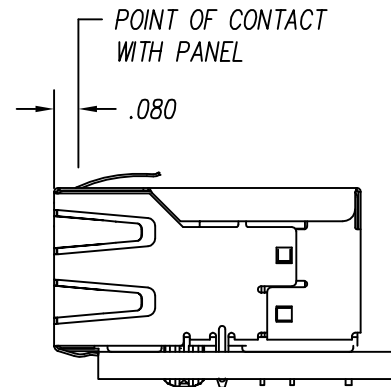
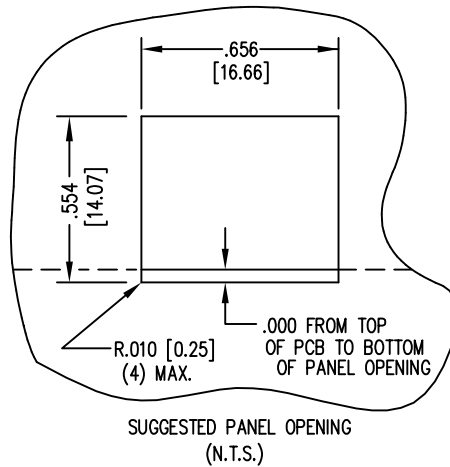

MI50005 / 24-0266

Bel Stewart Connector
11118 Susquehanna Trail, South
Glen Rock, Pa 17327-9199
717.234.7512

MagJack

<http://www.stewartconnector.com>

THIS DRAWING AND THE SUBJECT MATTER SHOWN THEREON ARE CONFIDENTIAL AND PROPERTY OF BEL STEWART CONNECTOR AND SHALL NOT BE REPRODUCED, COPIED, OR USED IN ANY MANNER WITHOUT PRIOR WRITTEN CONTENT OF BEL STEWART CONNECTOR. THE SUBJECT MATTER MAY BE PATENTED OR A PATENT MAY BE PENDING.

SHEET
4 OF 4

DRAWING NO.

SI-50146 REV. 01