

HIGH SPEED LAN MAGNETICS

- Recommended for use with Quality Semiconductor's QS6611 or QS6612 transceivers
- Dual, 2-port and quad, 4-port designs create optimum board space, electrical design and cost efficiencies
- 350µH OCL (inductance) with 8mA DC bias applied
- Low profile, SMT packaging, rated to 225°C peak IR reflow temperature
- 2000 Vrms isolation
- Multi-port applications

ELECTRICALS AT 25°C

Part No.	Insertion Loss (dB) Typ	Return Loss (dB) Min	Return Loss (dB) Min	Return Loss (dB) Min	Crosstalk (dB) Min	Common to Diff Mode Rej (dB) Min		Common to Common Mode Rej (dB) Min		Schematic
	1MHz-100MHz	1MHz-30MHz	30MHz-60MHz	60MHz-80MHz	1MHz-100MHz	30MHz	100MHz	30MHz	100MHz	
S558-5999-77	-1.0	-16	16-20log(f/30MHz)	-10	-35	-50	-30	-50	-30	A
S558-5999-83	-1.0	-16	16-20log(f/30MHz)	-10	-35	-50	-30	-50	-30	B

SCHEMATICS

A

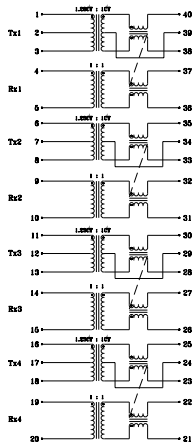

B

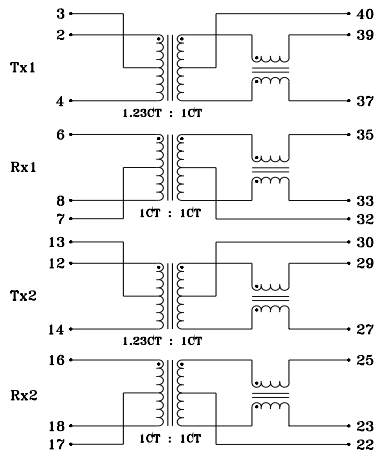

MECHANICAL

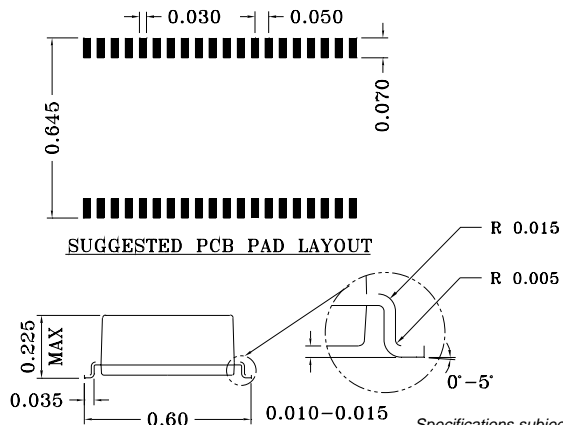
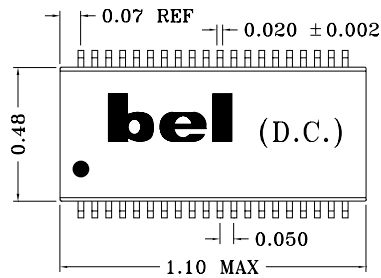

Specifications subject to change without notice.

960009A

APPLICATION CIRCUIT

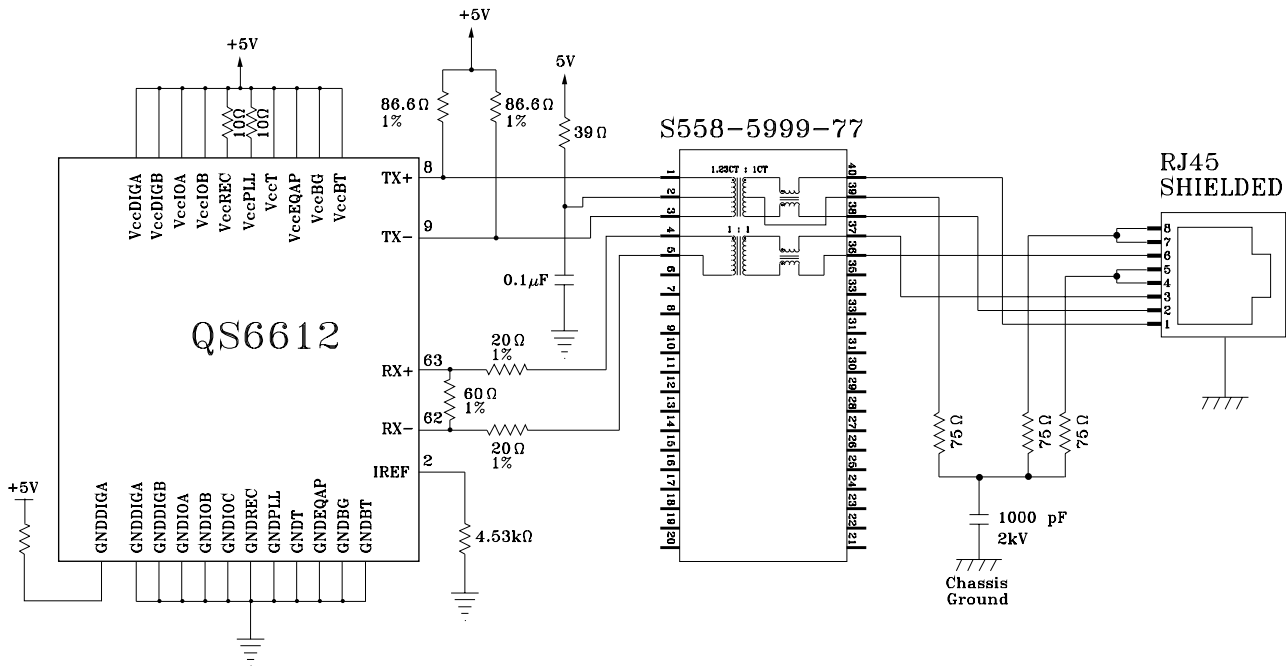

*Only one port shown.

APPLICATION NOTES

- These Bel part types have been designed for use in 100 Mbps or 10/100 Mbps data transmission systems over category 5 UTP/STP cable. Each Bel part type provides superior EMI noise suppression, high voltage isolation, wave shaping and fast, but controlled rise times. All parts meet IEEE 802.3 standards, which includes 350μH OCL (inductance) when 8mA of DC bias is applied.
- Implementation of these part types with the QS6611 can be achieved and requires higher current created by changing the 5 volt resistors from 86Ω to 100Ω and the IREF resistor from 4.53KΩ to 4.75KΩ.
- Bel's low profile, surface mount packaging is ideal for high speed pick and place machinery. Parts can be shipped on tape and reel for high speed placement. Construction processes have been implemented for thermal compatibility with high temperature IR reflow assembly processing. Post dipping of leads assist with PC board solderability. Each part is optically inspected to meet rigid coplanarity requirements.

Specifications subject to change without notice.