



SANYO Semiconductors

## DATA SHEET

## LA75710VA

Monolithic Linear IC

— NTSC Support TV and VCR

## VIF/SIF Signal Processing IC

## Overview

The LA75710VA is an NTSC support VIF/SIF signal processing IC that adopts a semi-adjustment-free system. The video-S/N and audio-S/N characteristics are improved. Further, it includes a circuit to prevent video over modulation. For the AFT function it adopts digital AFT. PLL detection is adopted in the FM detector. A 5V power-supply voltage is used to match that used in most multimedia systems. In addition, this IC also includes a buzz canceller to suppress Nyquist buzz and provide high audio quality.

## Functions

- VIF Block: VIF Amplifier, PLL Detector, IF AGC, RF AGC, Equalizer, amplifier, Buzz Canceller, Digital AFT, FLL
- 1st SIF Block: 1st SIF Amplifier, 1st SIF Detector
- SIF Block: Limiter Amplifier, PLL FM detector
- Others: IF SW (45.75MHz, 58.75MHz)

## Specifications

Maximum Ratings at Ta = 25°C

Parameter	Symbol	Conditions	Ratings	Unit
Maximum Supply voltage	V <sub>CC</sub>		6	V
Circuit voltage	V <sub>16</sub>		V <sub>CC</sub>	V
	V <sub>21</sub>		V <sub>CC</sub>	V
Circuit Current	I <sub>5</sub>		-3	mA
	I <sub>11</sub>		-7	mA
	I <sub>23</sub>		-2	mA
Allowable power dissipation	P <sub>d max</sub>	Ta ≤ 75°C *	500	mW
Operating temperature	T <sub>opr</sub>		-20 to +75	°C
Storage temperature	T <sub>stg</sub>		-55 to +150	°C

\* When mounted on a 65×72×1.6mm<sup>3</sup>, glass epoxy circuit board.

■ Any and all SANYO Semiconductor products described or contained herein do not have specifications that can handle applications that require extremely high levels of reliability, such as life-support systems, aircraft's control systems, or other applications whose failure can be reasonably expected to result in serious physical and/or material damage. Consult with your SANYO Semiconductor representative nearest you before using any SANYO Semiconductor products described or contained herein in such applications.

■ SANYO Semiconductor assumes no responsibility for equipment failures that result from using products at values that exceed, even momentarily, rated values (such as maximum ratings, operating condition ranges, or other parameters) listed in products specifications of any and all SANYO Semiconductor products described or contained herein.

SANYO Semiconductor Co., Ltd.

TOKYO OFFICE Tokyo Bldg., 1-10, 1 Chome, Ueno, Taito-ku, TOKYO, 110-8534 JAPAN

# LA75710VA

## Operating Ranges at $T_a = 25^\circ\text{C}$

Parameter	Symbol	Conditions	Ratings	Unit
Recommended supply voltage	$V_{CC}$		5.0	V
Operating supply voltage	$V_{CC\text{ op}}$		4.5 to 5.5	V

## Electrical Characteristics at $T_a = 25^\circ\text{C}$ , $V_{CC} = 5\text{V}$

### VIF Block

Parameter	Symbol	Conditions	Ratings			Unit
			min	typ	max	
Circuit current 1	$I_8$		49	54	59	mA
Circuit current 2	$I_4$		9	11	13	mA
Maximum RF AGC voltage	$V_{14H}$		$V_{CC}-0.5$	$V_{CC}$		V
Minimum RF AGC voltage	$V_{14L}$			0	0.5	V
Input sensitivity	$V_i$	Video out 2	34	40	46	$\text{dB}\mu\text{V}$
AGC range	$G_R$		52	56		dB
Maximum allowable input	$V_i\text{ max}$		95	100		$\text{dB}\mu\text{V}$
No-signal video output voltage	$V_5$		2.48	2.72	2.96	V
Sync. Signal tip voltage	$V_{5\text{tip}}$		0.8	1.0	1.2	V
Video output amplitude	$V_{O\text{TV}}$		1.3	1.5	1.7	Vp-p
Black noise threshold voltage	$V_{\text{BTH}}$		0.40	0.65	0.90	V
Black noise clamp voltage	$V_{\text{BCL}}$		1.3	1.6	1.9	V
Video S/N	S/N		52	56		dB
C-S best	IC-S	P/C = P/S = 10dB	45	50		dB
Frequency characteristics	$F_c$	6MHz	-3	-1.5		dB
Differential gain	DG			2.0	5	%
Differential phase	DP			2.0	4	$^\circ\text{C}$
No signal AFT voltage	$V_{21}$		2.2	2.5	2.8	V
Maximum AFT voltage	$V_{21H}$		$V_{CC}-0.7$	$V_{CC}-0.5$	$V_{CC}$	V
Minimum AFT voltage	$V_{21L}$		0	0.5	0.7	V
AFT detection sensitivity	$S_f$		8.5	12.5	16.5	$\text{mV/kHz}$
AFT output resolution	Res-aft			3.125		$\text{kHz/bit}$
VIF input resistance	$R_i$			1.0		$\text{k}\Omega$
VIF input capacitance	$C_i$			3		pF
APC hold range (U)	$F_{\text{hu}}$		2.0	2.4		MHz
APC hold range (L)	$F_{\text{hl}}$			-2.4	-2.0	MHz
APC pull-in range (U)	$F_{\text{pu}}$		2.0	2.4		MHz
APC pull-in range (L)	$F_{\text{pl}}$			-2.4	-2.0	MHz
VCO maximum variable range (U)	$D_{\text{fu}}$		2.1	2.6		MHz
VCO maximum variable range (L)	$D_{\text{fl}}$			-2.6	-2.1	MHz
VCO control sensitivity	$\beta$		2.0	3.5	5.0	$\text{kHz/mV}$
Synchronization ratio	VS		25.0	28.5	31.5	%

# LA75710VA

## 1st SIF Block (pin 15: 41.25MHz input)

Parameter	Symbol	Conditions	Ratings			Unit
			min	typ	max	
Conversion gain	$V_G$	$S = 40dB\mu$	44	48	52	dB
Output level	SO	$S = 90dB\mu$	100	11	120	$dB\mu V$
SIF carrier output level	Gbpf	Reference to SIF input (Pin1)	3	6	9	dB
1st SIF maximum input	$S_i$ max		105	110		$dB\mu V$
1st SIF input resistance	$R_i$ (SIF)	41.25MHz		2		$K\Omega$
1st SIF input capacitance	$C_i$ (SIF)	41.25MHz		3		PF

## SIF Block (pin 1: 4.5MHz input)

Parameter	Symbol	Conditions	Ratings			Unit
			min	typ	max	
Limiting sensitivity	$V_{ji}$ (lim)		40	46	52	$dB\mu V$
FM detector output voltage	$V_{O\text{FM}}$		420	500	600	mVrms
AMR	AMR	$\pm 25kHz$	54	60		dB
Distortion	THD			0.3	0.7	%
SIF S/N	S/N (FM)		65	71		dB

## Control Block

Parameter	Symbol	Conditions	Ratings			Unit
			min	typ	max	
AFT mute level control voltage	$V_{17}$				2.0	V

## IF System Switch

The IF frequency is 45.75MHz when pin 13 is in the A-(1) state, and is 58.75MHz when that pin is in the A-(2) state.

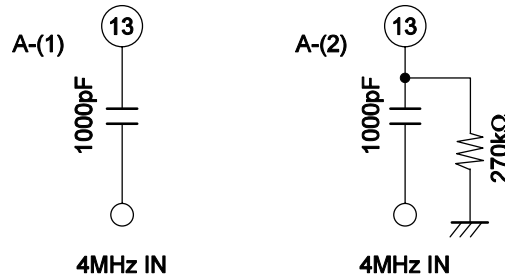

## AFT Muting Level

The AFT muting level is the high level when pin 17 is open, and is the middle level ( $V_{CC}/2$ ) when pin 17 is connected to ground. \*  $V_{CC}$  at 5V.

# LA75710VA

## Package Dimensions

unit : mm

3287

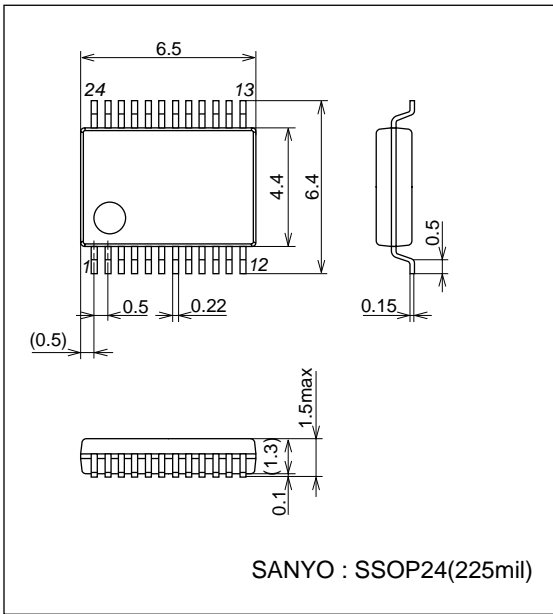

## Pin Assignment

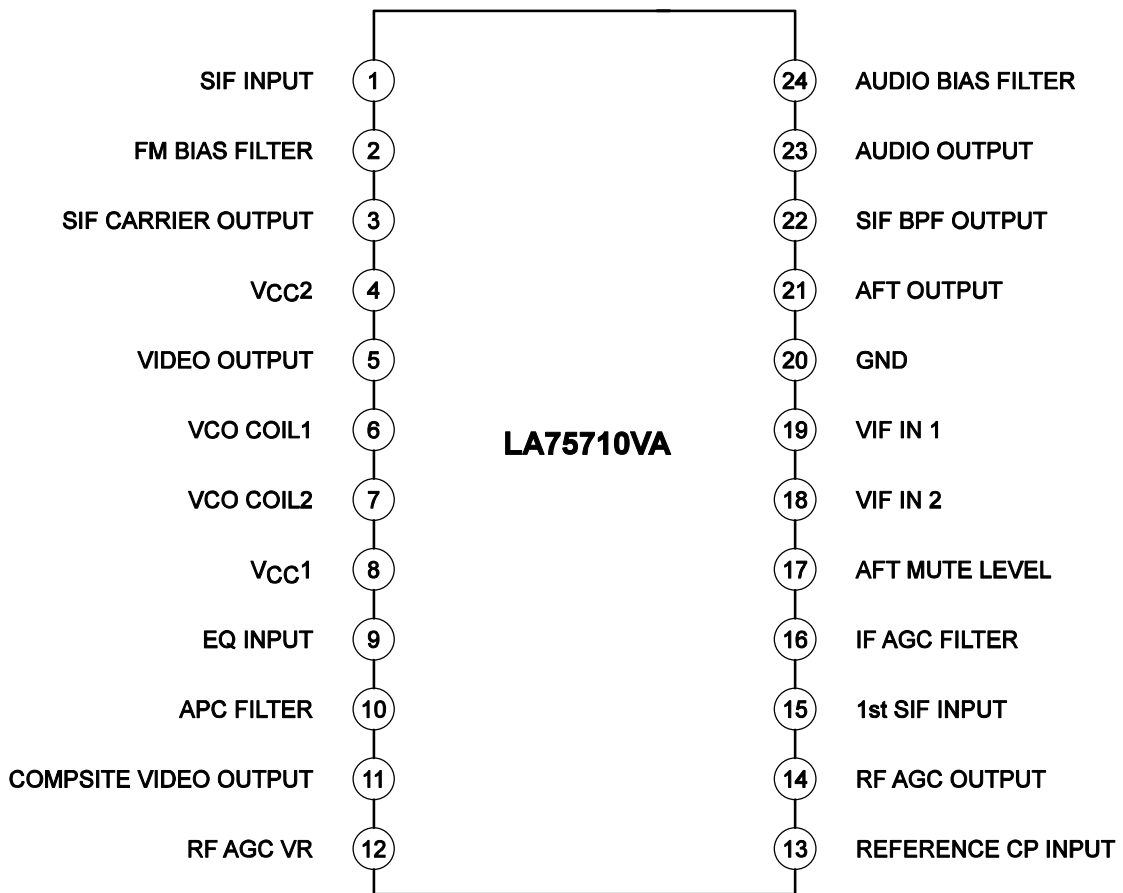

Top view

# LA75710VA

## Block Diagram and AC Characteristics Test Circuit

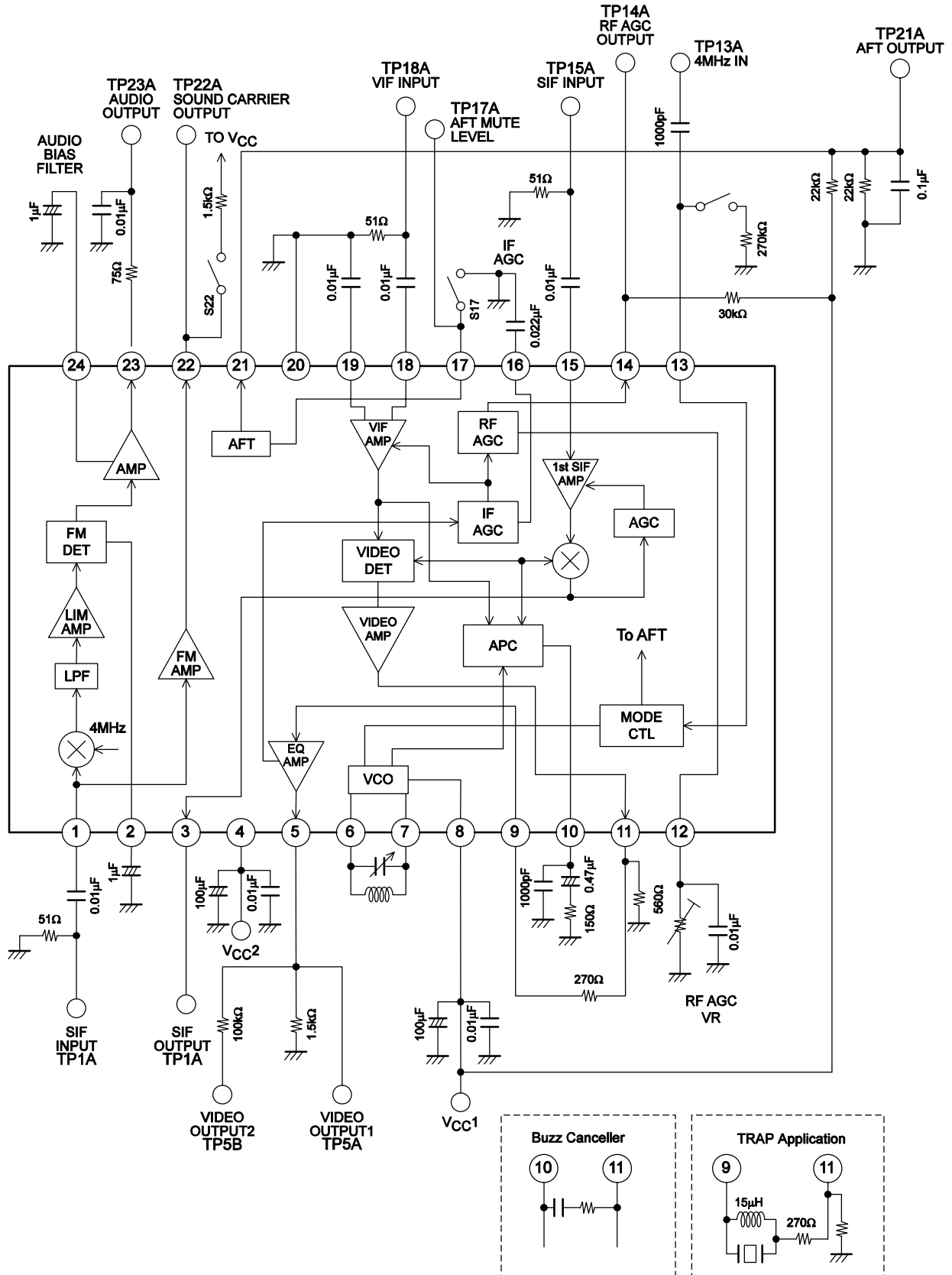

# LA75710VA

## Pin Function

Pin No.	Pin name	Function	Equivalent circuit
1	SIF INPUT	SIF input. The input impedance is about 1k $\Omega$ . Since buzzing and buzz beating can occur if interference enters this input pin, care must be taken when design the pattern layout for this pin. Note that the video and chrominance signals are especially likely to interface with the audio signal. Also, the VIF carrier signal can also cause interference.	
2	FM BIAS FILTER	FM detector bias line filter input. Used to improve the FM detector signal-to-noise ratio. C1 should be at least 0.47 $\mu$ F, and 1 $\mu$ F is recommended. If the FM detector is not used, connect pin 2 to ground through a 2k $\Omega$ resistor. This stops the FM detector VCO.	
3	SIF CARRIER OUTPUT	SIF carrier output. A 200 $\Omega$ resistor is inserted in series with an emitter-follower output.	
4 8	V <sub>CC</sub>	Use the shortest distance possible when decoupling Capacitors V <sub>CC</sub> and ground.	
5 9	EQ amp	Equalizer circuit. This circuit is used to correct the video signal frequency characteristics. Pin 9 is the EQ amplifier input	

Continued on next page.

# LA75710VA

Continued from preceding page.

Pin No.	Pin name	Function	Equivalent circuit
6 7	VCO COIL	VCO tank circuit used for video signal detection. This VCO is a vector synthesis VCO.	
10	APC FILTER	PLL detector APC filter connection. For this APC filter we recommend: R = 150 to 390Ω C = 0.47μF	
11	COMPOSIT VIDEO OUTPUT	Output for the video signal that includes the SIF carrier. A resistor must be inserted between pin 9 and ground to acquire adequate drive capability R2 ≥ 560Ω	
12	RF AGC VR	RF AGC VR connection. This pin sets the tuner RF AGC operating point. Also, the FM output and the video output can both be muted the same time by connecting this pin to GND.	
13	REFERENCE CP INPUT	Reference frequency input from this pin. The reference frequency is 3.58MHz, inserting 270KΩ between this pin to GND. The reference frequency is 4.0MHz, this pin leaving open.	

Continued on next page.

# LA75710VA

Continued from preceding page.

Pin No.	Pin name	Function	Equivalent circuit
14	RF AGC OUTPUT	RF AGC OUT PUT. This output controls the tuner RF AGC. A protective 200Ω resistor is inserted in series with the open collector out put. Determine the external bleeder resistor value in accordance with the specifications of the tuner.	
15	1ST SIF INPUT	First SIF input. ADC cut capacitor must be used in the input circuit. If a SAW filter is used: The first SIF sensitivity can be increased by inserting an inductor between the SAW filter and the IC to neutralize the SAW filter output capacitance and the IC input capacitance. When used in an intercarrier system: This pin (pin 13) maybe connect to GND.	
16	IF AGC FILTER	IF AGC filter connection. The signal peak-detected by the built-in AGC detector is converted to the AGC voltage at pin 16. Additionally, a second AGC filter (a lag-lead filter) used to create the dual time constants is provided internally in the IC. Use a 0.022μF capacitor as the external capacitor, and other characteristics.	
17	AFT MUTE LEVEL	The MUTE voltage of AFT is set up this pin. It becomes a voltage that generated by an external bleeder resistor, when this pin is connected with GND. It becomes a High voltage (V <sub>CC</sub> ) when this pin is leaving open.	
18 19	VIF INPUT	VIF amplifier input. The input circuit is a balanced circuit, and the input constants are: R≈1.0kΩ C≈3pF	
20	GND		

Continued on next page.



# LA75710VA

Continued from preceding page.

Pin No.	Pin name	Function	Equivalent circuit
21	AFT OUTPUT	<p>AFT output.</p> <p>AFT center voltage is generated by an external bleeder.</p> <p>The AFT gain is increased by increasing the resistance of this external bleeder resistor.</p> <p><math>R \geq 22k\Omega</math></p> <p><math>C = 0.1\mu F</math></p>	
22	SIF BPF OUTPUT	<p>The output to the external bandpass filter is passed through an internal 6dB amplifier before being output.</p>	
23	AUDIO OUTPUT	<p>Audio FM detector output. A 54KΩ resistor is inserted in series with an emitter-follower output.</p> <p>For applications that support mono: Create an external deemphasis circuit.</p> <p><math>t = C \times R1</math></p>	
24	AUDIO BIAS FILTER	<p>Connection for a filter used to hold the FM detector output DC voltage fixed. Normally, a 1μF electrolytic capacitor should be used. The capacitance should be increased if the low band (around 50Hz) frequency characteristics need to be improved.</p> <p>The FM detector output level can be reduced and the FM dynamic range can be increased by inserting a resistor and a capacitor in series between pin 24 and GND.</p>	

- Specifications of any and all SANYO Semiconductor products described or contained herein stipulate the performance, characteristics, and functions of the described products in the independent state, and are not guarantees of the performance, characteristics, and functions of the described products as mounted in the customer's products or equipment. To verify symptoms and states that cannot be evaluated in an independent device, the customer should always evaluate and test devices mounted in the customer's products or equipment.
- SANYO Semiconductor Co., Ltd. strives to supply high-quality high-reliability products. However, any and all semiconductor products fail with some probability. It is possible that these probabilistic failures could give rise to accidents or events that could endanger human lives, that could give rise to smoke or fire, or that could cause damage to other property. When designing equipment, adopt safety measures so that these kinds of accidents or events cannot occur. Such measures include but are not limited to protective circuits and error prevention circuits for safe design, redundant design, and structural design.
- In the event that any or all SANYO Semiconductor products (including technical data, services) described or contained herein are controlled under any of applicable local export control laws and regulations, such products must not be exported without obtaining the export license from the authorities concerned in accordance with the above law.
- No part of this publication may be reproduced or transmitted in any form or by any means, electronic or mechanical, including photocopying and recording, or any information storage or retrieval system, or otherwise, without the prior written permission of SANYO Semiconductor Co., Ltd.
- Any and all information described or contained herein are subject to change without notice due to product/technology improvement, etc. When designing equipment, refer to the "Delivery Specification" for the SANYO Semiconductor product that you intend to use.
- Information (including circuit diagrams and circuit parameters) herein is for example only; it is not guaranteed for volume production. SANYO Semiconductor believes information herein is accurate and reliable, but no guarantees are made or implied regarding its use or any infringements of intellectual property rights or other rights of third parties.

This catalog provides information as of August, 2006. Specifications and information herein are subject to change without notice.