

## Z86E72/73

### OTP IR MICROCONTROLLERS

#### FEATURES

Part	ROM (KB)	RAM* (Bytes)	I/O	Voltage Range
Z86E73	32	256	31	3.0V to 5.5V
Z86E72	16	768	31	3.0V to 5.5V

**Note:** \*General-Purpose

- Low Power Consumption - 60 mW (Typical)
- Two Standby Modes (Typical)
  - STOP - 2  $\mu$ A
  - HALT - 0.8 mA
- Special Architecture to Automate Both Generation and Reception of Complex Pulses or Signals:
  - One Programmable 8-Bit Counter/Timer with Two Capture Registers
  - One Programmable 16-Bit Counter/Timer with One Capture Register
  - Programmable Input Glitch Filter for Pulse Reception
- Five Priority Interrupts
  - Three External
  - Two Assigned to Counter/Timers
- Two Independent Comparators with Programmable Interrupt Polarity
- On-Chip Oscillator that Accepts a Crystal, Ceramic Resonator, LC, RC (mask option), or External Clock Drive
- Software Selectable 200 kOhms Pull-Ups on Ports 0 and Port 2
  - All Eight Port 2 Bits at One Time or Not Pull-Ups Automatically Disabled Upon Selecting Individual Pins as Outputs.
- Software Mouse/Trackball Interface on P00 Through P03

#### GENERAL DESCRIPTION

The Z86E7X family of IR (Infrared) CCP™ (Consumer Controller Processor) are OTP-based members of the Z8® single-chip microcontroller family with 256 or 768 bytes of general-purpose RAM. The only differentiating factor between the E72/73 versions is the availability of RAM and ROM. This EPROM Microcontroller family of OTP IR controllers also offer the use of external memory which enables this Z8 microcontroller to be used where code flexibility is required. Zilog's CMOS microcontrollers offer fast execution, efficient use of memory, sophisticated interrupts, input/output bit manipulation capabilities, automated pulse generation/reception, and easy hardware/software system expansion along with cost-effective and low power consumption.

The Z86E7X architecture is based on Zilog's 8-bit microcontroller core with an Expanded Register File to allow access to register mapped peripherals, I/O circuits, and powerful counter/timer circuitry. The CCP offers a flexible I/O scheme, an efficient register and address space structure, and a number of ancillary features that are useful in many consumer, automotive, computer peripheral, and battery operated hand-held applications.

CCP™ applications demand powerful I/O capabilities. The Z86L7X family fulfills this with five package options in which the E72/73/L74 versions provide 31 pins of dedicated input and output. These lines are grouped into four ports. Each port consists of eight lines (Port 3 has seven lines of I/O and one Pref comparator input) and is config-

## GENERAL DESCRIPTION (Continued)

urable under software control to provide timing, status signals, parallel I/O with or without handshake, and an address/data bus for interfacing external memory.

There are five basic address spaces available to support a wide range of configurations: Program Memory, Register File, Expanded Register File, Extended Data RAM and External Memory. The register file is composed of 256 bytes of RAM. It includes four I/O port registers, 16 control and status registers and the rest are General Purpose registers. The Extended Data RAM adds 512 (E72) of usable general-purpose registers. The Expanded Register File consists of two additional register groups (F and D).

To unburden the program from coping with such real-time problems as generating complex waveforms or receiving and demodulating complex waveform/pulses, the Z86E7X

family offers a new intelligent counter/timer architecture with 8-bit and 16-bit counter/timers (Figure 1). Also included are a large number of user-selectable modes, and two on-board comparators to process analog signals with separate reference voltages (Figure 2).

**Notes:** All Signals with a preceding front slash, "/", are active Low, e.g., B/W (WORD is active Low); /B/W (BYTE is active Low, only).

Power connections follow conventional descriptions below:

Connection	Circuit	Device
Power	V <sub>CC</sub>	V <sub>DD</sub>
Ground	GND	V <sub>SS</sub>

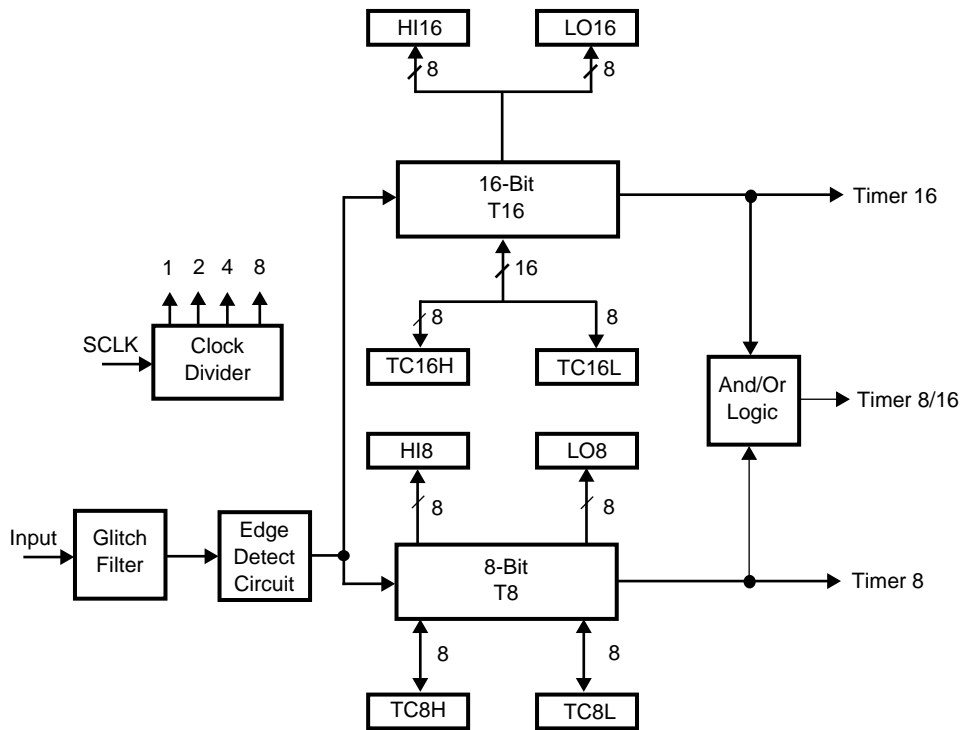
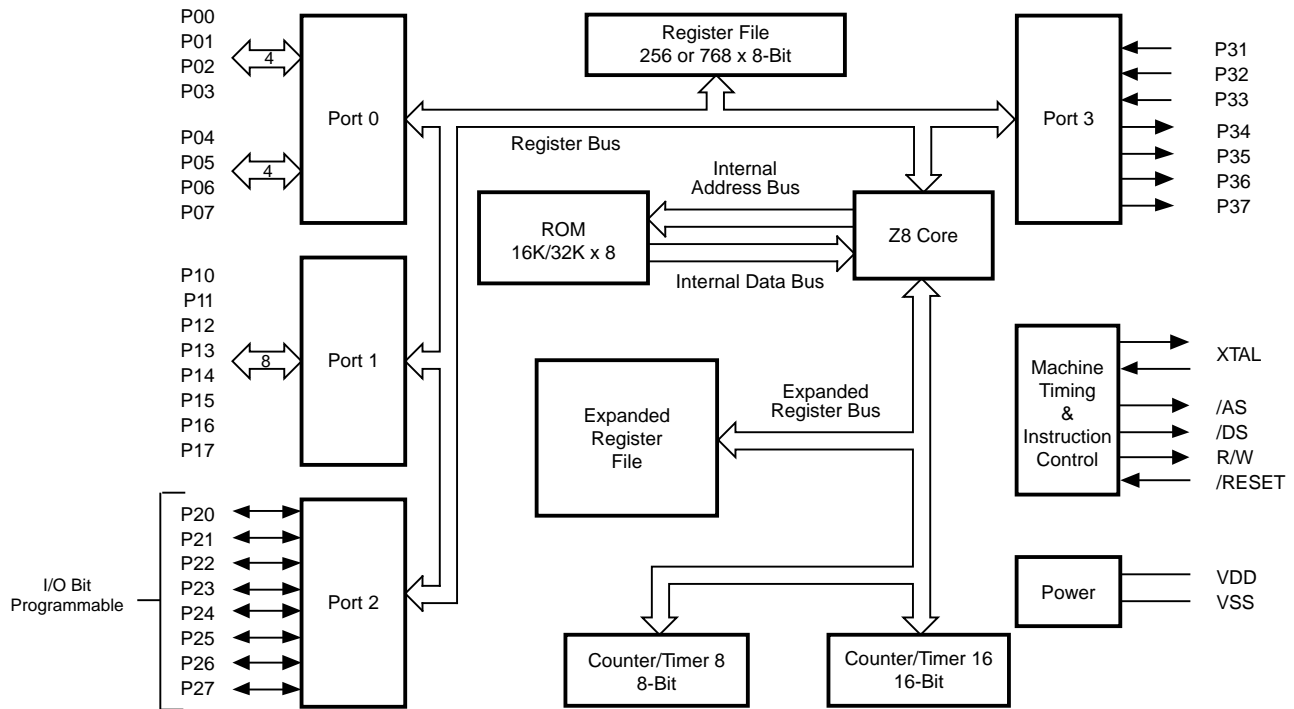
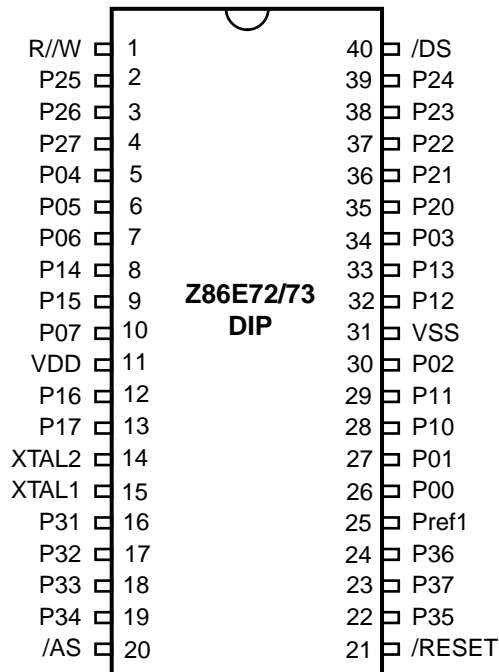


Figure 1. Z86E7X Counter/Timer Block Diagram



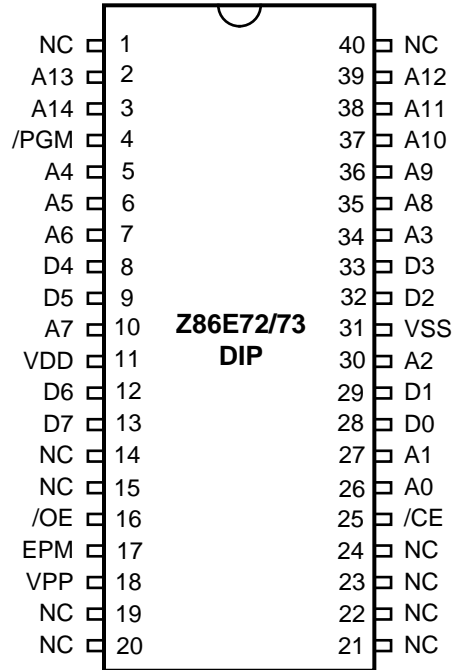
**Figure 2. Z86E7X Functional Block Diagram**

## PIN DESCRIPTION

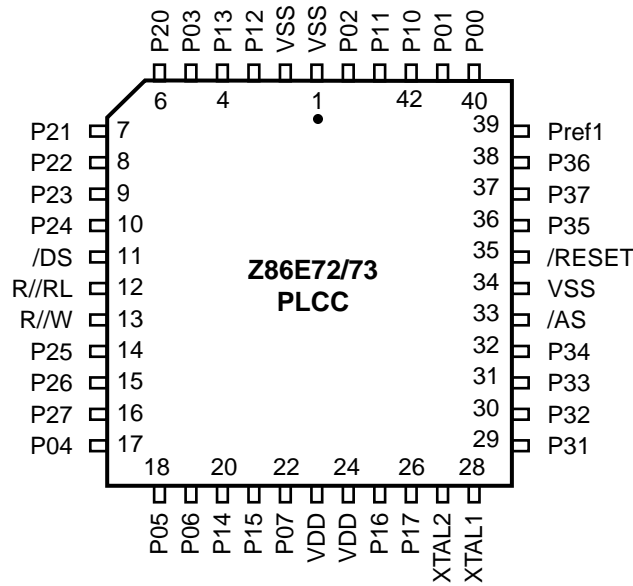


**Figure 3. 40-Pin DIP Pin Assignments (Standard Mode)**

**PIN DESCRIPTION (Continued)**



**Figure 4. 40-Pin DIP Pin Assignments (EPROM Mode)**



**Figure 5. 44-Pin PLCC Pin Assignments (Standard Mode)**

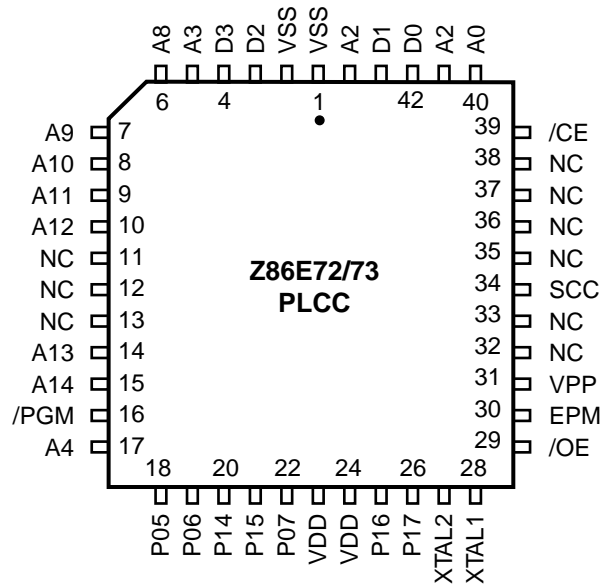


Figure 6. 44-Pin PLCC Pin Assignments (EPROM Mode)

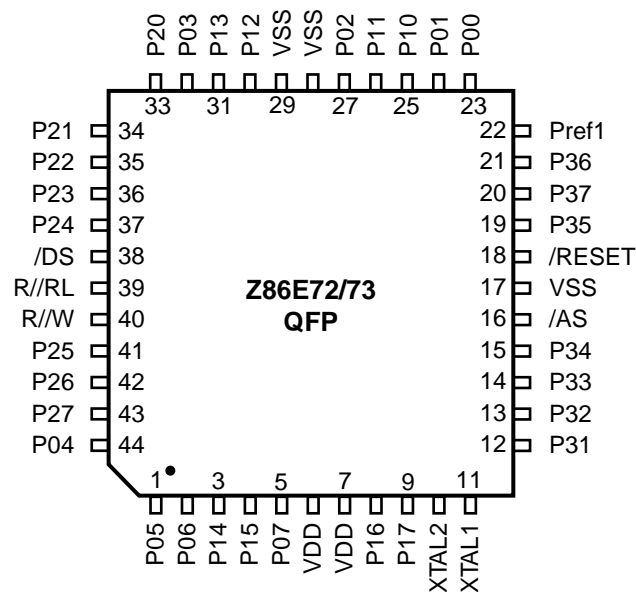
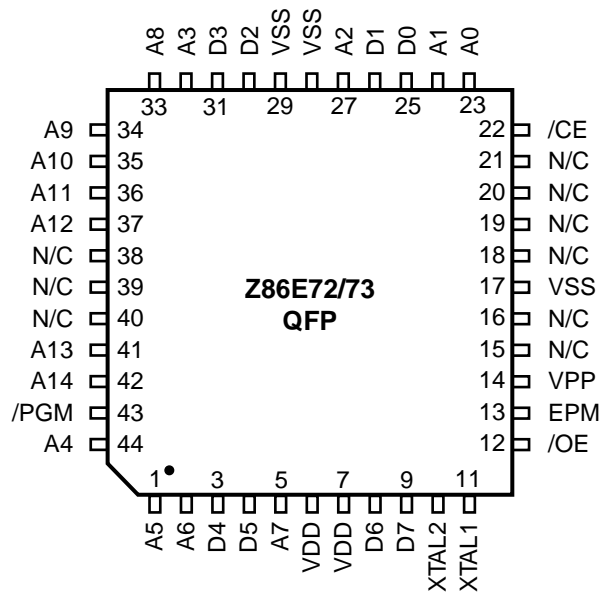


Figure 7. 44-Pin QFP Pin Assignments (Standard Mode)

**PIN DESCRIPTION (Continued)**



**Figure 8. 44-Pin QFP Pin Assignments (EPROM Mode)**

**Table 1. Pin Identification (Standard Mode)**

40-Pin DIP #	44-Pin PLCC #	44-Pin QFP #	Symbol	Direction	Description
26	40	23	P00	Input/Output	Port 0 is Nibble Programmable.
27	41	24	P01	Input/Output	Port 0 can be configured as A15-A8 external program
30	44	27	P02	Input/Output	
34	5	32	P03	Input/Output	ROM Address Bus.
5	17	44	P04	Input/Output	Port 0 can be configured as a
6	18	1	P05	Input/Output	mouse/trackball input.
7	19	2	P06	Input/Output	
10	22	5	P07	Input/Output	
28	42	25	P10	Input/Output	Port 1 is byte programmable.
29	43	26	P11	Input/Output	Port 1 can be configured as multiplexed A7-A0/D7-D0 external program ROM Address/Data Bus
32	3	30	P12	Input/Output	
33	4	31	P13	Input/Output	
8	20	3	P14	Input/Output	.
9	21	4	P15	Input/Output	
12	25	8	P16	Input/Output	
13	26	9	P17	Input/Output	

Table 1. Pin Identification (Standard Mode)

40-Pin DIP #	44-Pin PLCC #	44-Pin QFP #	Symbol	Direction	Description
35	6	33	P20	Input/Output	Port 2 pins are individually configurable as input or output
36	7	34	P21	Input/Output	
37	8	35	P22	Input/Output	
38	9	36	P23	Input/Output	
39	10	37	P24	Input/Output	
2	14	41	P25	Input/Output	
3	15	42	P26	Input/Output	
4	16	43	P27	Input/Output	
16	29	12	P31	Input	IRQ2/Modulator input
17	30	13	P32	Input	IRQ0
18	31	14	P33	Input	IRQ1
19	32	15	P34	Output	T8 output
22	36	19	P35	Output	T16 output
24	38	21	P36	Output	T8/T16 output
23	37	20	P37	Output	
20	33	16	/AS	Output	Address Strobe
40	11	38	/DS	Output	Data Strobe
1	13	40	R/W	Output	Read/Write
21	35	18	/RESET	Input	Reset
15	28	11	XTAL1	Input	Crystal, Oscillator Clock
14	27	10	XTAL2	Output	Crystal, Oscillator Clock
11	23, 24	6, 7	V <sub>DD</sub>		Power Supply
31	1, 2, 34	17, 28, 29	V <sub>SS</sub>		Ground
25	39	22	Pref1	Input	Comparator 1 Reference
NC	12	39	R//RL	Input	ROM//ROMless

**PIN DESCRIPTION** (Continued)

**Table 2. Z86E72/73 40-Pin DIP Identification (EPROM Mode)**

40-Pin #	Symbol	Function	Direction
1	N/C	Not Connected	
2-3	A13-14	Address 13,14	Input
4	/PGM	Program Mode	Input
5-7	A4-A6	Address 4,5,6	Input
8-9	D4-D5	Data 4,5	Input/Output
10	A7	Address 7	Input
11	V <sub>DD</sub>	Power Supply	
12-13	D6-D7	Data 6,7	Input/Output
14-15	N/C	Not Connected	
16	/OE	Output Enable	Input
17	EPM	EPROM Prog.Mode	Input
18	V <sub>PP</sub>	Prog. Voltage	Input
19-24	N/C	Not Connected	
25	/CE	Chip Enable	Input
26-27	A0-A1	Address 0,1	Input
28-29	D0-D1	Data 0, 1	Input/Output
30	A2	Address 2	Input
31	V <sub>SS</sub>	Ground	
32-33	D2-D3	Data 2,3	Input/Output
34	A3	Address 3	Input
35-39	A8-A12	Address 8,9,10,11,12	Input
40	N/C	Not Connected	



**Table 3. Z86E72/73 44-Pin QFP/PLCC Pin Identification(EPROM Mode)**

<b>44-Pin QFP</b>	<b>44-Pin PLCC</b>	<b>Symbol</b>	<b>Function</b>	<b>Direction</b>
1-2	18-19	A5-A6	Address 5,6	Input
3-4	20-21	D4-D5	Data 4,5	Input/Output
5	22	A7	Address 7	Input
6-7	23-24	V <sub>DD</sub>	Power Supply	
8-9	25-26	D6-D7	Data 6,7	Input/Output
10	27	XTAL2	Crystal Oscillator Clock	
11	28	XTAL1	Crystal Oscillator Clock	
12	29	/OE	Output Enable	Input
13	30	EPM	EPROM Prog. Mode	Input
14	31	V <sub>PP</sub>	Prog. Voltage	Input
15-16	32-33	N/C	Not Connected	
17	34	V <sub>SS</sub>	Ground	
18-21	35-38	N/C	Not Connected	
22	39	/CE	Chip Select	Input
23-24	40-41	A0-A1	Address 0,1	Input
25-26	42-43	D0-D1	Data 0,1	Input/Output
27	44	A2	Address 2	Input
28-29	1-2	V <sub>SS</sub>	Ground	
30-31	3-4	D2-D3	Data 2, 3	Input/Output
32	5	A3	Address 3	Input
33-37	6-10	A8-A12	Address 8,9,10,11,12	Input
38-40	11-13	N/C	Not Connected	
41-42	14-15	A13-A14	Address 13,14	Input
43	16	/PGM	Prog. Mode	Input
44	17	A4	Address 4	Input

## ABSOLUTE MAXIMUM RATINGS

Symbol	Description	Min	Max	Units
$V_{CC}$	Supply Voltage (*)	-0.3	+7.0	V
$T_{STG}$	Storage Temp.	-65°	+150°	C
$T_A$	Oper. Ambient Temp.		†	C

**Notes:**

\* Voltage on all pins with respect to GND.

† See Ordering Information.

Stresses greater than those listed under Absolute Maximum Ratings may cause permanent damage to the device. This is a stress rating only; operation of the device at any condition above those indicated in the operational sections of these specifications is not implied. Exposure to absolute maximum rating conditions for an extended period may affect device reliability.

## STANDARD TEST CONDITIONS

The characteristics listed below apply for standard test conditions as noted. All voltages are referenced to GND. Positive current flows into the referenced pin (Figure 13).

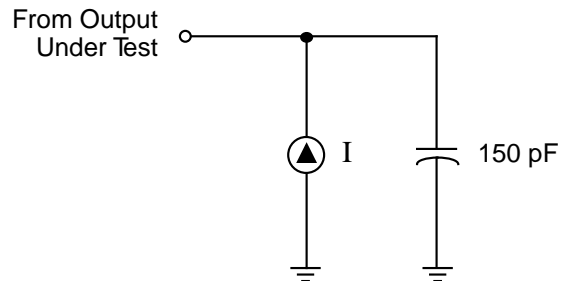


Figure 9. Test Load Diagram

## CAPACITANCE

$T_A = 25^\circ\text{C}$ ,  $V_{CC} = \text{GND} = 0\text{V}$ ,  $f = 1.0 \text{ MHz}$ , unmeasured pins returned to GND.

Parameter	Max
Input capacitance	12 pF
Output capacitance	12 pF
I/O capacitance	12 pF

**DC CHARACTERISTICS**
**Preliminary**

Sym.	Parameter	V <sub>CC</sub>	T <sub>A</sub> = 0°C to +70°C		Typical @ 25°C	Units	Conditions
			Min	Max			
	Max Input Voltage	3.0V		7		V	I <sub>IN</sub> 250 μA
		5.5V		7		V	I <sub>IN</sub> 250 μA
V <sub>CH</sub>	Clock Input High Voltage	3.0V	0.9 V <sub>CC</sub>	V <sub>CC</sub> + 0.3		V	Driven by External Clock Generator
		5.5V	0.9 V <sub>CC</sub>	V <sub>CC</sub> + 0.3		V	
V <sub>CL</sub>	Clock Input Low Voltage	3.0V	V <sub>SS</sub> - 0.3	0.2 V <sub>CC</sub>		V	Driven by External Clock Generator
		5.5V	V <sub>SS</sub> - 0.3	0.2 V <sub>CC</sub>		V	
V <sub>IH</sub>	Input High Voltage	3.0V	0.7 V <sub>CC</sub>	V <sub>CC</sub> + 0.3	0.5 V <sub>CC</sub>	V	
		5.5V	0.7 V <sub>CC</sub>	V <sub>CC</sub> + 0.3	0.5 V <sub>CC</sub>	V	
V <sub>IL</sub>	Input Low Voltage	3.0V	V <sub>SS</sub> - 0.3	0.2 V <sub>CC</sub>	0.5 V <sub>CC</sub>	V	
		5.5V	V <sub>SS</sub> - 0.3	0.2 V <sub>CC</sub>	0.5 V <sub>CC</sub>	V	
V <sub>OH1</sub>	Output High Voltage	3.0V	V <sub>CC</sub> - 0.4		2.9	V	I <sub>OH</sub> = -0.5 mA
		5.5V	V <sub>CC</sub> - 0.4		5.4	V	I <sub>OH</sub> = -0.5 mA
V <sub>OH2</sub>	Output High Voltage (P00, P01, P36, P37)	3.0V	V <sub>CC</sub> 0.7			V	I <sub>OH</sub> = -7 mA
		5.5V	V <sub>CC</sub> 0.7			V	I <sub>OH</sub> = -7 mA
V <sub>OL1</sub>	Output Low Voltage	3.0V		0.4	0.1	V	I <sub>OL</sub> = 1.0 mA
		5.5V		0.4	0.2	V	I <sub>OL</sub> = 4.0 mA
V <sub>OL2*</sub>	Output Low Voltage	3.0V		0.8	0.5	V	I <sub>OL</sub> = 5.0 mA
		5.5V		0.8	0.3	V	I <sub>OL</sub> = 7.0 mA
V <sub>OL2</sub>	Output Low Voltage (P00, P01, P36, P37)	3.0V		0.8	0.3	V	I <sub>OL</sub> = 10 mA
		5.5V		0.8	0.2	V	I <sub>OL</sub> = 10 mA
V <sub>RH</sub>	Reset Input High Voltage	3.0V	0.8 V <sub>CC</sub>	V <sub>CC</sub>	1.5	V	
		5.5V	0.8 V <sub>CC</sub>	V <sub>CC</sub>	2.5	V	
V <sub>RI</sub>	Reset Input Low Voltage	3.0V	V <sub>SS</sub> - 0.3	0.2 V <sub>CC</sub>	0.9		
		5.5V	V <sub>SS</sub> - 0.3	0.2 V <sub>CC</sub>	1.8		
V <sub>OFFSET</sub>	Comparator Input Offset Voltage	3.0V		25	10	mV	
		5.5V		25	10	mV	
I <sub>IL</sub>	Input Leakage	3.0V	-1	1	< 1	μA	V <sub>IN</sub> = 0V, V <sub>CC</sub>
		5.5V	-1	1	< 1	μA	V <sub>IN</sub> = 0V, V <sub>CC</sub>
I <sub>OL</sub>	Output Leakage	3.0V	-1	1	< 1	μA	V <sub>IN</sub> = 0V, V <sub>CC</sub>
		5.5V	-1	1	< 1	μA	V <sub>IN</sub> = 0V, V <sub>CC</sub>
I <sub>IR</sub>	Reset Input Current	3.0V		-230	-50	μA	
		5.5V		-400	-80	μA	
I <sub>CC</sub>	Supply Current (WDT off)	3.0V		10	4	mA	@ 8.0 MHz
		5.5V		15	10	mA	@ 8.0 MHz

**DC CHARACTERISTICS** (Continued)

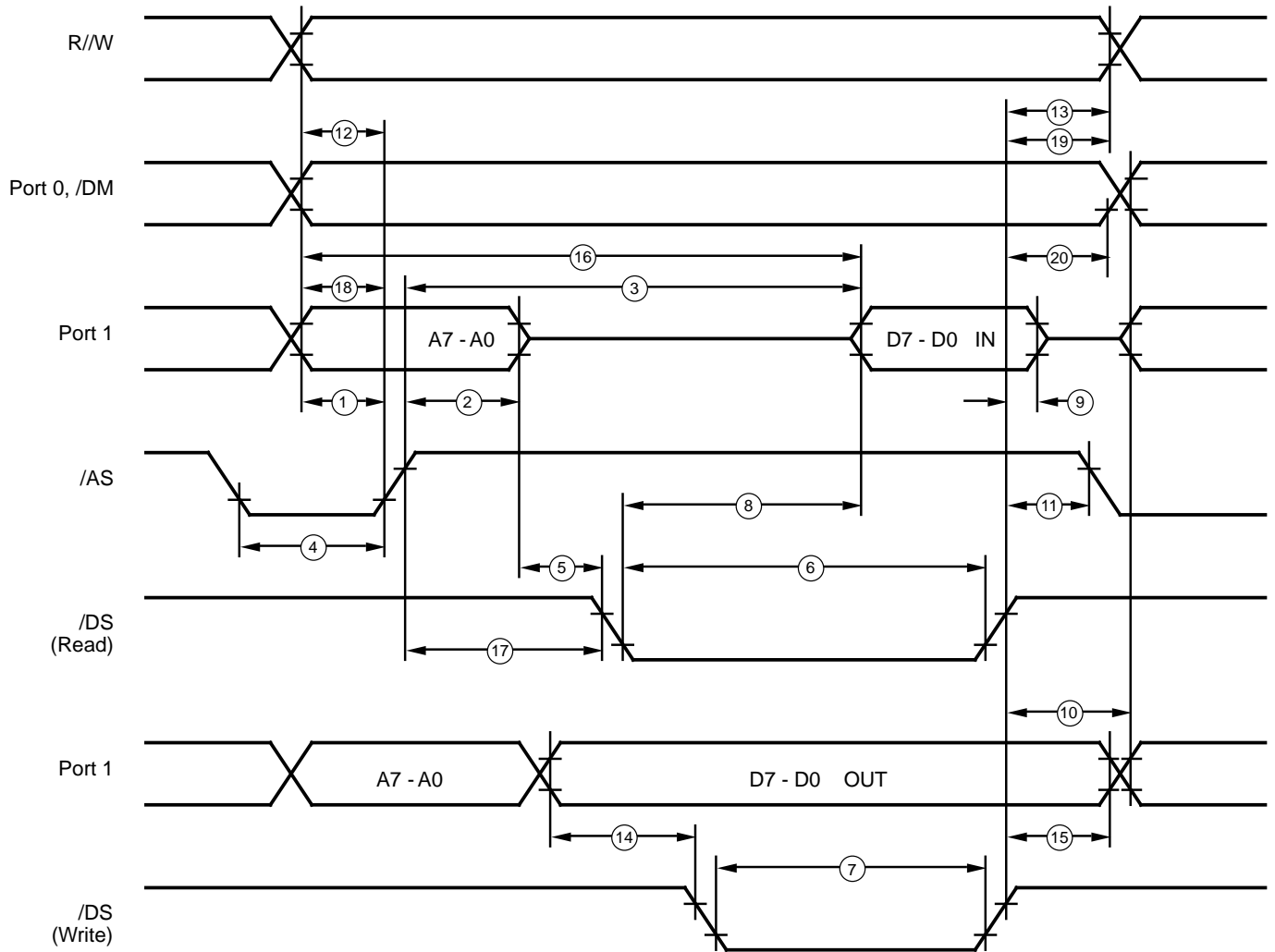
Sym.	Parameter	V <sub>CC</sub>	T <sub>A</sub> = 0°C to +70°C		Typical @ 25°C	Units	Conditions	Notes
			Min	Max				
I <sub>CC1</sub>	Standby Current (WDT Off)	3.0V		3	1	mA	HALT Mode V <sub>IN</sub> = 0V, V <sub>CC</sub> @ 8.0 MHz	1,2
		5.5V		5	4	mA	HALT Mode V <sub>IN</sub> = 0V, V <sub>CC</sub> @ 8.0 MHz	1,2
	3.0V		2	0.8	mA	Clock Divide-by-16 @ 8.0 MHz	1,2	
	5.5V		4	2.5	mA	Clock Divide-by-16 @ 8.0 MHz	1,2	
I <sub>CC2</sub>	Standby Current	3.0V		8	2	µA	STOP Mode V <sub>IN</sub> = 0V, V <sub>CC</sub> WDT is not Running	3,5
		5.5V		10	3	µA	STOP Mode V <sub>IN</sub> = 0V, V <sub>CC</sub> WDT is not Running	3,5
	3.0V		500	310	µA	STOP Mode	3,5	
	5.5V		800	600	µA	V <sub>IN</sub> = 0V, V <sub>CC</sub> WDT is Running		
T <sub>POR</sub>	Power-On Reset	3.0V	12	75	18	ms		
		5.5V	5	20	7	ms		
V <sub>ram</sub>	Static RAM Data Retention Voltage	V <sub>ram</sub>	0.8		0.5	V		6
V <sub>LV</sub> (V <sub>bo</sub> )	V <sub>CC</sub> Low Voltage Protection			2.15	1.7	V	8 MHz max Ext. CLK Freq.	4
<b>Notes:</b>	<b>I<sub>CC1</sub></b>	<b>Typ</b>	<b>Max</b>	<b>Unit</b>	<b>Frequency</b>			
	Crystal/Resonator	3.0 mA	5	mA	8.0 MHz			
	External Clock Drive	0.3 mA	5	mA	8.0 MHz			

1. All outputs unloaded, inputs at rail.
2. CL1 = CL2 = 100 pF
3. Same as note [4] except inputs at V<sub>CC</sub>.
4. The V<sub>LV</sub> increases as the temperature decreases.
5. Oscillator stopped.
6. Oscillator stops when VCC falls below V<sub>lv</sub> limit
7. 32 kHz clock driver input.

\* All Outputs excluding P00, P01, P36, and P37.

**AC CHARACTERISTICS**

**External I/O or Memory Read and Write Timing**



**Figure 10. External I/O or Memory Read/Write Timing**

## AC CHARACTERISTICS

### Preliminary

### External I/O or Memory Read and Write Timing Table

No.	Symbol	Parameter	V <sub>CC</sub>	T <sub>A</sub> = 0°C to +70°C		Units	Notes
				16 MHz			
				Min.	Max.		
1	TdA(AS)	Address Valid to /AS Rising Delay	3.0V	55		ns	2
			5.5V	55		ns	
2	TdAS(A)	/AS Rising to Address Float Delay	3.0V	70		ns	2
			5.5V	70		ns	
3	TdAS(DR)	/AS Rising to Read Data Required Valid	3.0V		400	ns	1,2
			5.5V		400	ns	
4	TwAS	/AS Low Width	3.0V	80		ns	2
			5.5V	80		ns	
5	Td	Address Float to /DS Falling	3.0V	0		ns	
			5.5V	0		ns	
6	TwDSR	/DS (Read) Low Width	3.0V	300		ns	1,2
			5.5V	300		ns	
7	TwDSW	/DS (Write) Low Width	3.0V	165		ns	1,2
			5.5V	165		ns	
8	TdDSR(DR)	/DS Falling to Read Data Required Valid	3.0V		260	ns	1,2
			5.5V		260	ns	
9	ThDR(DS)	Read Data to /DS Rising Hold Time	3.0V	0		ns	
			5.5V	0		ns	
10	TdDS(A)	/DS Rising to Address Active Delay	3.0V	85		ns	2
			5.5V	95		ns	
11	TdDS(AS)	/DS Rising to /AS Falling Delay	3.0V	60		ns	2
			5.5V	70		ns	
12	TdR/W(AS)	R/W Valid to /AS Rising Delay	3.0V	70		ns	2
			5.5V	70		ns	
13	TdDS(R/W)	/DS Rising to R/W Not Valid	3.0V	70		ns	2
			5.5V	70		ns	
14	TdDW(DSW)	Write Data Valid to /DS Falling (Write) Delay	3.0V	80		ns	2
			5.5V	80		ns	
15	TdDS(DW)	/DS Rising to Write Data Not Valid Delay	3.0V	70		ns	2
			5.5V	80		ns	
16	TdA(DR)	Address Valid to Read Data Required Valid	3.0V		475	ns	1,2
			5.5V		475	ns	
17	TdAS(DS)	/AS Rising to /DS Falling Delay	3.0V	100		ns	2
			5.5V	100		ns	
18	TdDM(AS)	/DM Valid to /AS Falling Delay	3.0V	55		ns	2
			5.5V	55		ns	
19	TdDS(DM)	/DS Rise to /DM Valid Delay	3.0V	70		ns	
			5.5V	70		ns	
20	ThDS(A)	/DS Rise to Address Valid Hold Time	3.0V	70		ns	
			5.5V	70		ns	

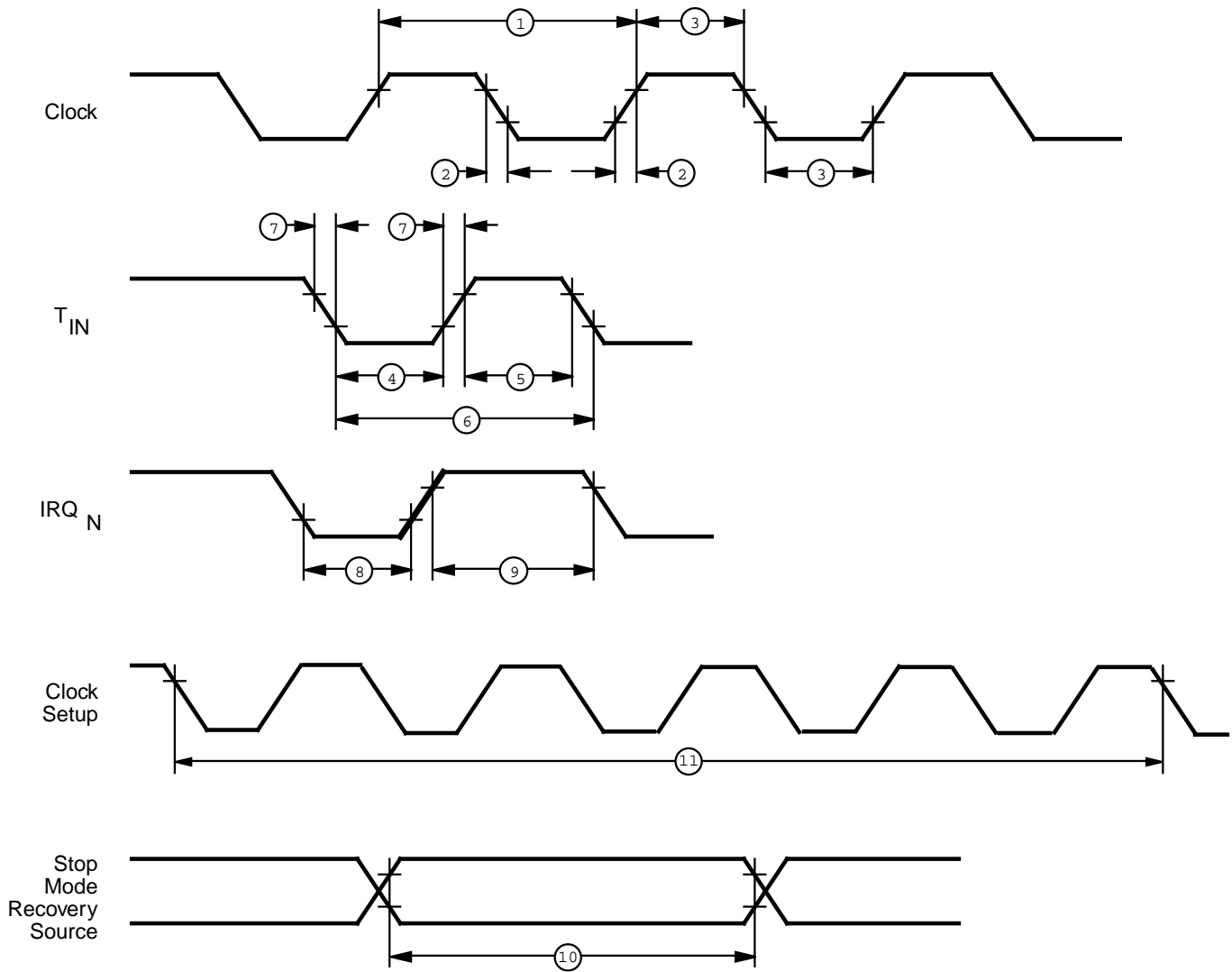
#### Notes:

1. When using extended memory timing add 2 TpC.
2. Timing numbers given are for minimum TpC.

Standard Test Load

All timing references use 0.9 V<sub>CC</sub> for a logic 1 and 0.1 V<sub>CC</sub> for a logic 0.

**AC CHARACTERISTICS**  
Additional Timing Diagram



**Figure 11. Additional Timing**

## AC CHARACTERISTICS

### Preliminary

### Additional Timing Table

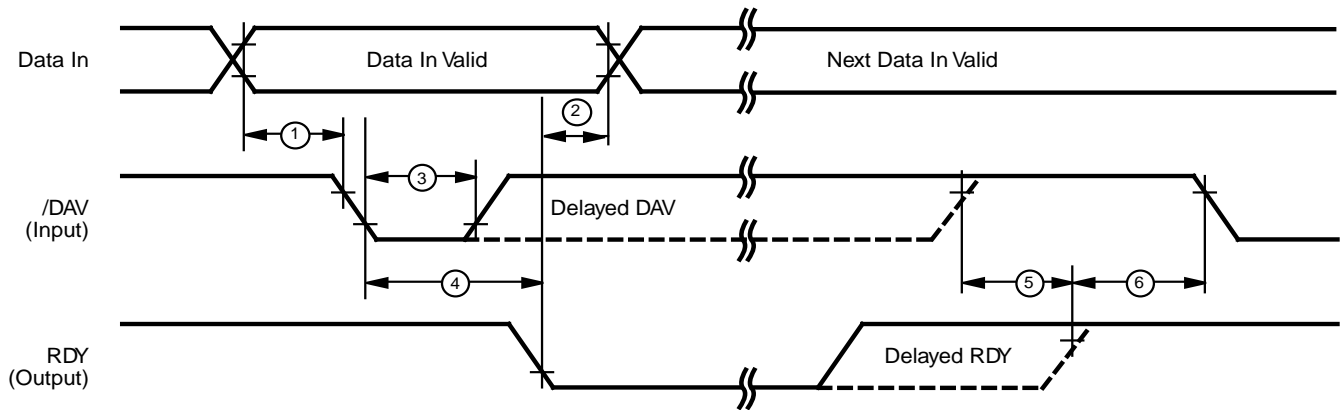
No	Symbol	Parameter	V <sub>CC</sub>	T <sub>A</sub> = 0°C to +70°C		Units	Notes
				Min	Max		
1	TpC	Input Clock Period	3.0V	121	DC	ns	1
			5.5V	121	DC	ns	1
2	TrC,TfC	Clock Input Rise and Fall Times	3.0V		25	ns	1
			5.5V		25	ns	1
3	TwC	Input Clock Width	3.0V	37		ns	1
			5.5V	37		ns	
4	TwTinL	Timer Input Low Width	3.0V	100		ns	1
			5.5V	70		ns	
5	TwTinH	Timer Input High Width	3.0V	3TpC			1
			5.5V	3TpC			
6	TpTi	Timer Input Period	3.0V	8TpC			1
			5.5V	8TpC			
7	TrTin,TfTi	Timer Input Rise and Fall Timers	3.0V	100		ns	1
			5.5V	70		ns	1
8A	TwIL	Interrupt Request Low Time	3.0V	100		ns	1,2
			5.5V	70		ns	1,2
8B	TwIL	Int. Request Low Time	4.5V	3TpC			1,3
			5.5V	5TpC			1,3
9	TwIH	Interrupt Request Input High Time	4.5V	5TpC			1,2
			5.5V	5TpC			1,2
10	Twsm	Stop-Mode Recovery Width Spec	3.0V	12		ns	7
			5.5V	12		ns	7
			3.0V	5TpC			6
			5.5V	5TpC			6
11	Tost	Oscillator Start-up Time	3.0V		5TpC		4
			5.5V		5TpC		
12	Twdt	Watch-Dog Timer Delay Time	3.0V	12	75	ms	
			5.5V	5	20	ms	
			3.0V	25	150	ms	
			5.5V	10	40	ms	
			3.0V	50	300	ms	
			5.5V	20	80	ms	
			3.0V	225	1200	ms	
			5.5V	80	320	ms	

#### Notes:

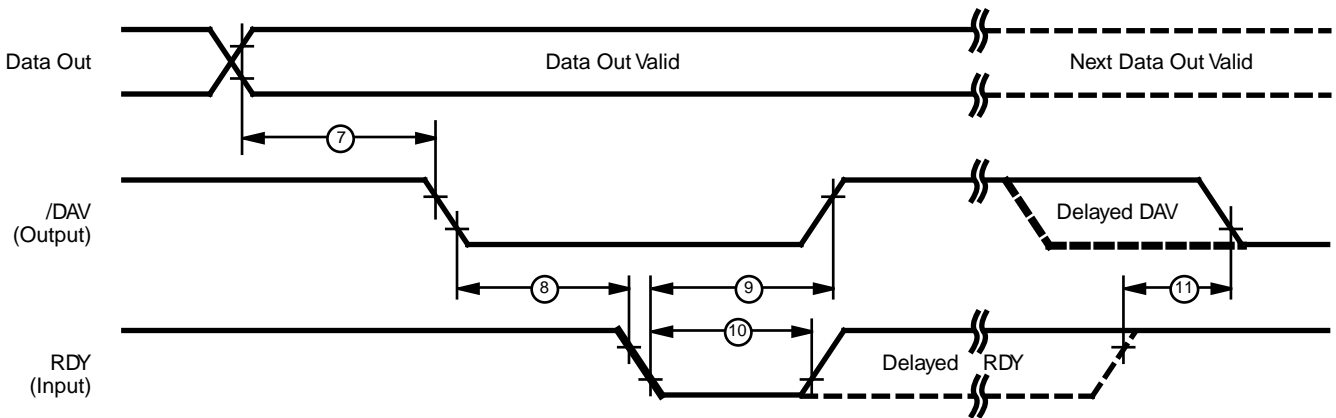
1. Timing Reference uses 0.9 V<sub>CC</sub> for a logic 1 and 0.1 V<sub>CC</sub> for a logic 0.
2. Interrupt request through Port 3 (P33-P31).
3. Interrupt request through Port 3 (P30).
4. SMR – D5 = 0
5. Reg. WDTMR
6. Reg. SMR – D5 = 0
7. Reg. SMR – D5 = 1



**AC CHARACTERISTICS**  
**Handshake Timing Diagrams**



**Figure 12. Input Handshake Timing**



**Figure 13. Output Handshake Timing**

## AC CHARACTERISTICS

Preliminary

Handshake Timing Table

No	Symbol	Parameter	V <sub>CC</sub>	T <sub>A</sub> = 0°C to +70°C 16 MHz		Data Direction
				Min	Max	
1	TsDI(DAV)	Data In Setup Time	4.0V	0		IN
			5.5V			IN
2	ThDI(DAV)	Data In Hold Time	4.0V	0		IN
			5.5V			0
3	TwDAV	Data Available Width	4.0V	155		IN
			5.5V			110
4	TdDAVI(RDY)	DAV Falling to RDY Falling Delay	4.0V		160	IN
			5.5V			115
5	TdDAVIId(RDY)	DAV Rising to RDY Falling Delay	4.0V		120	IN
			5.5V			80
6	TdRDYO(DAV)	RDY Rising to DAV Falling Delay	4.0V	0		IN
			5.5V			0
7	TdDO(DAV)	Data Out to DAV Falling Delay	4.0V	63		OUT
			5.5V			63
8	TdDAV0(RDY)	DAV Falling to RDY Falling Delay	4.0V	0		OUT
			5.5V			0
9	TdRDY0(DAV)	RDY Falling to DAV Rising Delay	4.0V		160	OUT
			5.5V			115
10	TwRDY	RDY Width	4.0V	110		OUT
			5.5V			80
11	TdRDY0d(DAV)	RDY Rising to DAV Falling Delay	4.0V		110	OUT
			5.5V			80

## PIN FUNCTIONS

**/DS** (Output, active Low). Data Strobe is activated once for each external memory transfer. For a READ operation, data must be available prior to the trailing edge of /DS. For WRITE operations, the falling edge of /DS indicates that output data is valid.

**/AS** (Output, active Low). Address Strobe is pulsed once at the beginning of each machine cycle. Address output is through Port 0/Port 1 for all external programs. Memory address transfers are valid at the trailing edge of /AS. Under program control, /AS is placed in the high-impedance state along with Ports 0 and 1, Data Strobe, and Read/Write.

**XTAL1** Crystal 1 (time-based input). This pin connects a parallel-resonant crystal, ceramic resonator, LC, or RC network or an external single-phase clock to the on-chip oscillator input.

**XTAL2** Crystal 2 (time-based output). This pin connects a parallel-resonant, crystal, ceramic resonant, LC, or RC network to the on-chip oscillator output.

**R//W** Read/Write (output, write Low). The R//W signal is Low when the CCP is writing to the external program or data memory.

**R//RL** (input). This pin, when connected to GND, disables the internal ROM and forces the device to function as a ROMless Z8. (Note that, when left unconnected or pulled high to  $V_{CC}$ , the part functions normally as a Z8 ROM version.)

**Port 0** (P07-P00). Port 0 is an 8-bit, bidirectional, CMOS compatible port. These eight I/O lines are configured under software control as a nibble I/O port, or as an address port for interfacing external memory. The output drivers are push-pull. Port 0 is placed under handshake control. In this configuration, Port 3, lines P32 and P35 are used as the handshake control /DAV0 and RDY0. Handshake signal direction is dictated by the I/O direction to Port 0 of the upper nibble P07-P04. The lower nibble must have the same direction as the upper nibble.

For external memory references, Port 0 can provide address bits A11-A8 (lower nibble) or A15-A8 (lower and upper nibble) depending on the required address space. If the address range requires 12 bits or less, the upper nibble of Port 0 can be programmed independently as I/O while the lower nibble is used for addressing. If one or both nibbles are needed for I/O operation, they must be configured by writing to the Port 0 mode register. After a hardware reset, Port 0 is configured as an input port.

Port 0 is set in the high-impedance mode if selected as an address output state along with Port 1 and the control signals /AS, /DS, and R//W (Figure 8).

A software option is available to program 0.4  $V_{DD}$  CMOS trip inputs on P00-P03. This allows direct interface to mouse/trackball IR sensors.

An optional 200 kOhm pull-up is available as a software option of all Port 0 bits with nibble select.

These pull-ups are disabled when configured (bit by bit) as an output.

PIN FUNCTIONS (Continued)

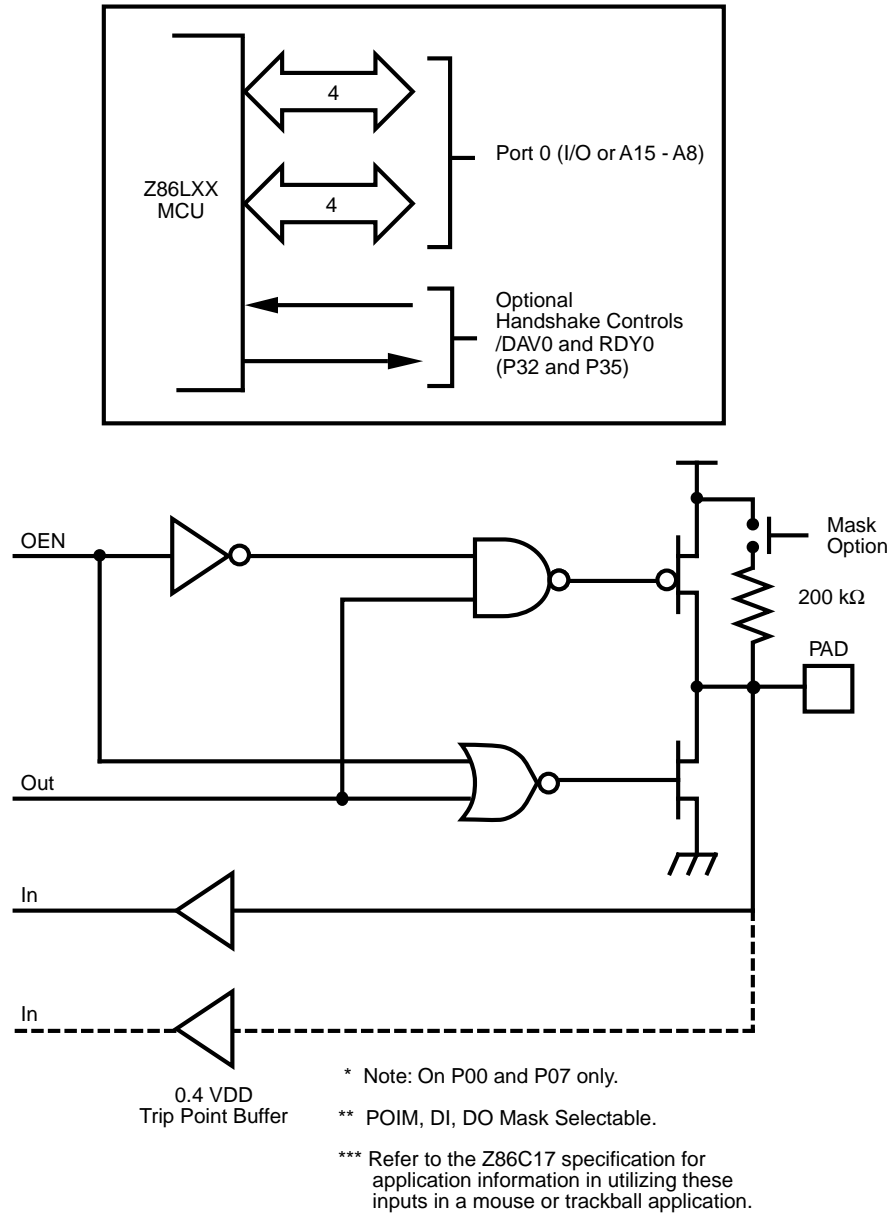


Figure 14. Port 0 Configuration

**Port 1 (P17-P10).** Port 1 is a multiplexed Address (A7-A0) and Data (D7-D0), CMOS compatible port. Port 1 is dedicated to the Zilog ZBus<sup>®</sup>-compatible memory interface. The operations of Port 1 are supported by the Address Strobe (/AS) and Data Strobe (/DS) lines, and by the Read/Write (R/W) and Data Memory (/DM) control lines. Data memory read/write operations are done through this

port (Figure 20). If more than 256 external locations are required, Port 0 outputs the additional lines.

Port 1 can be placed in the high-impedance state along with Port 0, /AS, /DS, and R/W, allowing the Z86L7X to share common resources in multiprocessor and DMA applications. Port1 can also be configured for standard port output mode.

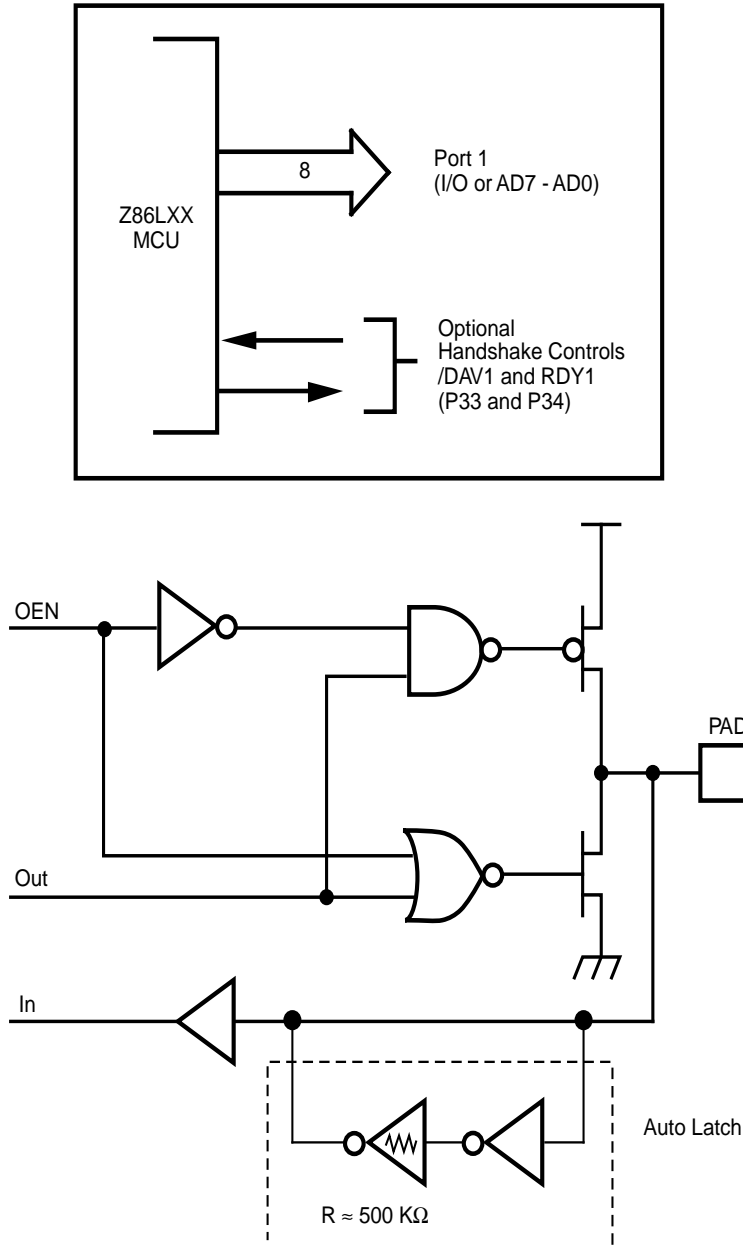


Figure 15. Port 1 Configuration

## PIN FUNCTIONS (Continued)

**Port 2 (P27-P20).** Port 2 is an 8-bit, bidirectional, CMOS compatible I/O port. These eight I/O lines can be independently configured under software control as inputs or outputs. Port 2 is always available for I/O operation. A software option is available to connect eight 200 kOhms ( $\pm 50\%$ ) pull-up resistors on this port. Bits programmed as outputs are globally programmed as either push-pull or open-drain. Port 2 may be placed under handshake control. In this configuration, Port 3 lines, P31 and P36 are used as the handshake controls lines /DAV2 and RDY2.

The handshake signal assignment for Port 3, lines P31 and P36 is dictated by the direction (input or output) assigned to Bit 7, Port 2 (Figure 10).

The CCP wakes up with the eight bits of Port 2 configured as inputs with open-drain outputs.

Port 2 also has an 8-bit input OR and an AND gate which can be used to wake up the part. P20 can be programmed to access the edge selection circuitry (Figure 21).

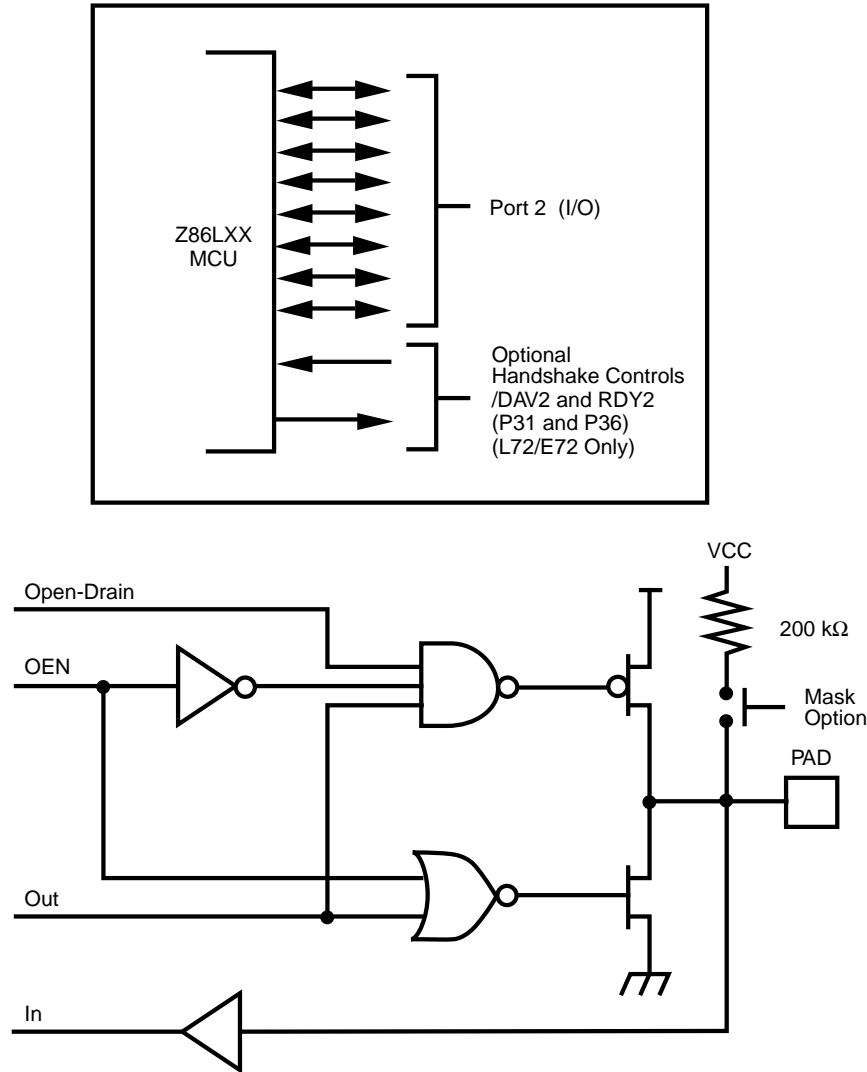


Figure 16. Port 2 Configuration

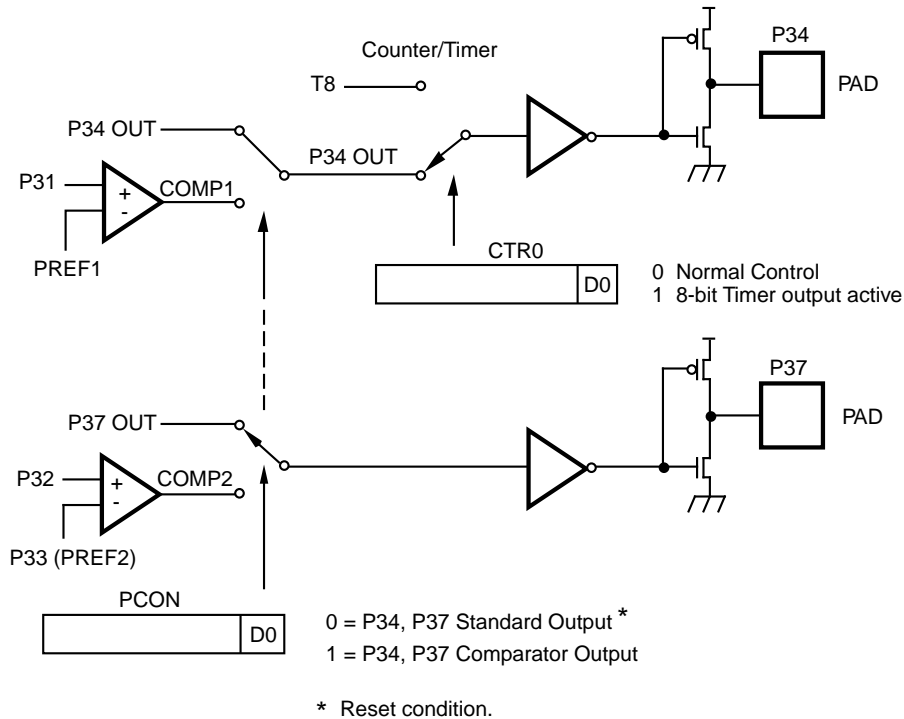
**Port 3** (P37-P31). Port 3 is a 7-bit, CMOS compatible three fixed input and four fixed output port. Port 3 consists of three fixed input (P33-P31) and four fixed output (P37-P34), and can be configured under software control for Input/Output, Interrupt, Port handshake, Data Memory functions and output from the counter/timers. P31, P32, and P33 are standard CMOS inputs; outputs are push-pull.

Two on-board comparators process analog signals on P31 and P32 with reference to the voltage on Pref1 and P33. The analog function is enabled by programming the Port 3 Mode Register (bit 1). P31 and P32 are programmable as rising, falling, or both edge triggered interrupts (IRQ regis-

ter bits 6 and 7). Pref1 and P33 are the comparator reference voltage inputs. Access to the Counter Timer edge detection circuit is through P31 or P20 (see CTR1 description).

Port 3 provides the following control functions: handshake for Ports 0, 1, and 2 (/DAV and RDY); three external interrupt request signals (IRQ2-IRQ0); Data Memory Select (/DM) (Table 8).

Port 3 also provides output for each of the counter/timers and the AND/OR Logic. Control is performed by programming bits D5-D4 of CTR1, bit 0 of CTR0 and bit 0 of CTR2.



**Figure 17. Port 3 Configuration**

**PIN FUNCTIONS** (Continued)

**Table 4. Pin Assignments**

Pin	I/O	C/T	Comp.	Int.	P0 HS	P1 HS	P2 HS	Ext
Pref1	IN		RF1					
P31	IN	IN	AN1	IRQ2			D/R	
P32	IN		AN2	IRQ0	D/R			
P33	IN		RF2	IRQ1		D/R		
P34	OUT	T8	A01			R/D		D/M
P35	OUT	T16			R/D			
P36	OUT	T8/16					R/D	
P37	OUT		A02					
P20	I/O	IN						

**Notes:**

HS = Handshake Signals

D = /DAV

R = RDY

**Comparator Inputs.** In Analog Mode, Port 3 (P31 and P32) have a comparator front end. The comparator reference is supplied to P33 and Pref1. In this mode, the P33 internal data latch and its corresponding IRQ1 is diverted to the SMR sources (excluding P31, P32, and P33) as shown in Figure 37. In digital mode, P33 is used as D3 of the Port 3 input register which then generates IRQ1 as shown in Figure 23.

**Notes:** Comparators are disabled/powered down by entering STOP mode. For P31-P33 to be used as a Stop-Mode recovery source, these inputs must be placed into digital mode.

**Comparator Outputs.** These may be programmed to be outputted on P34 and P37 through the PCON register (Figure 22).

**/RESET** (Input, active Low). Initializes the MCU. Reset is accomplished either through Power-On, Watch-Dog Timer, Stop-Mode Recovery, Low Voltage detection, or external reset. During Power-On Reset and Watch-Dog Timer Reset, the internally generated reset drives the reset pin Low for the POR time. Any devices driving the reset line should be open-drain in order to avoid damage from a possible conflict during reset conditions. Pull-up is provided internally. There is no condition internal to the L7X that will not allow an external reset to occur.



After the POR time, /RESET is a Schmitt-triggered input. To avoid asynchronous and noisy reset problems, the Z86L7X is equipped with a reset filter of four external clocks (4TpC). If the external reset signal is less than 4TpC in duration, no reset occurs. On the fifth clock after the reset is detected, an internal RST signal is latched and held for an internal register count of 18 external clocks, or for the duration of the external reset, whichever is longer.

During the reset cycle, /DS is held active Low while /AS cycles at a rate of TpC/2. Program execution begins at location 000CH, 5-10 TpC cycles after the RST is released. For Power-On Reset, the typical reset output time is 5 ms. **The Z86E7X devices do not have internal pull resistors on Port 3 inputs.**

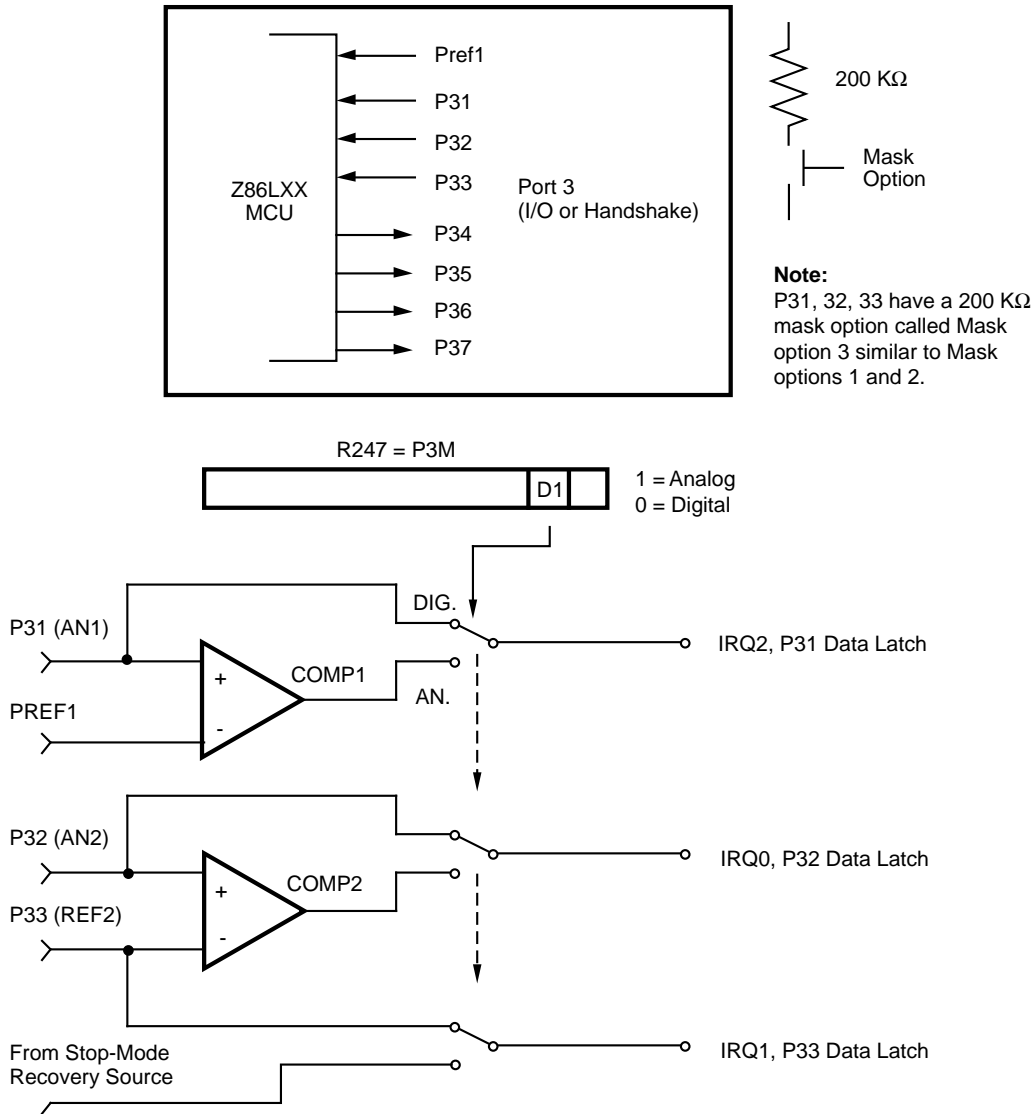


Figure 18. Port 3 Configuration

PIN FUNCTIONS (Continued)

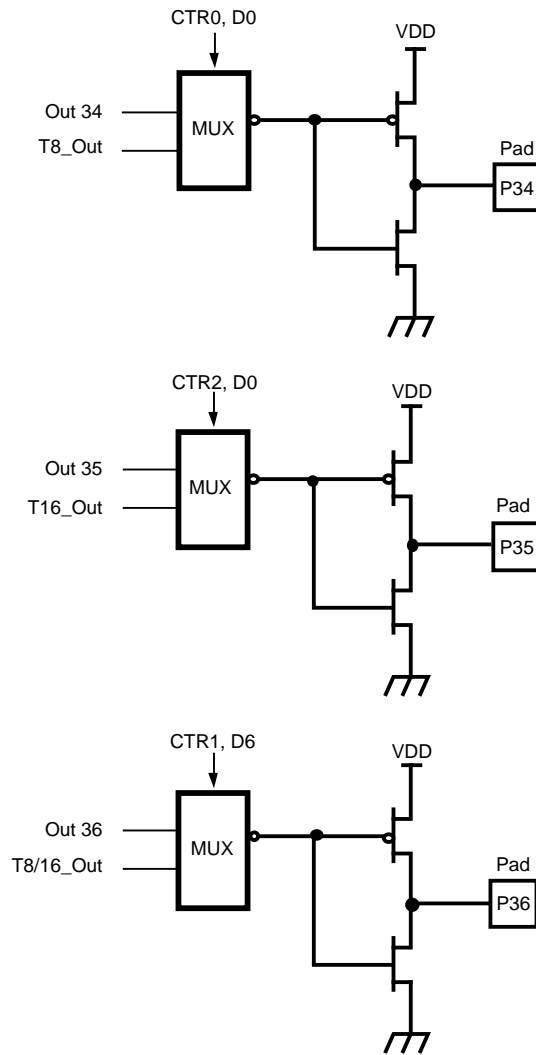


Figure 19. Port 3 Configuration

## FUNCTIONAL DESCRIPTION

The Z8<sup>®</sup> CCP incorporates special functions to enhance the Z8's functionality in consumer and battery operated applications.

**Reset.** The device is reset in one of the following conditions:

1. Power-On Reset
2. Watch-Dog Timer
3. Stop-Mode Recovery Source
4. Low Voltage Detection
5. External Reset

**Program Memory.** The Z86E72/73 addresses up to 16K/32 Kbytes of internal program memory, with the remainder being external memory (Figure 26). The first 12 bytes of program memory are reserved for the interrupt vectors. These locations contain five 16-bit vectors that correspond to the five available interrupts. Addresses of 16K/32K consist of on-chip OTP. At addresses 16K or 32K and greater, the E72/73 executes external program memory fetches (refer to external memory timing specifications).

**RAM.** The Z86E72 has a 768-byte RAM, 256 bytes make up the Register file. The remaining 512 bytes make up the Extended Data RAM. The Z86E73 has just the 256 bytes of the Register file.

**Extended Data RAM.** The Extended Data RAM of the Z86E72 occupies the address range FE00H-FFFFH (512 bytes). This range of addresses FD00H-FFFFH cannot be used to directly read from or write to external memory. Accessing the Extended Data RAM is accomplished by using LDE, LDEI, LDC, or LDCI instructions. Port 1 and Port 0 are free to be set as I/O or ADDR/DATA modes; except high-impedance when accessing Extended Data RAM. In addition, if the External Memory uses the same address range of the Extended Data RAM it can be used as the External Stack only.

**Note: The Extended Data RAM cannot be used as STACK or instruction/code memory. Accessing the Extended Data RAM has the following condition: P01M register bits D4-D3 cannot be set to 11.**

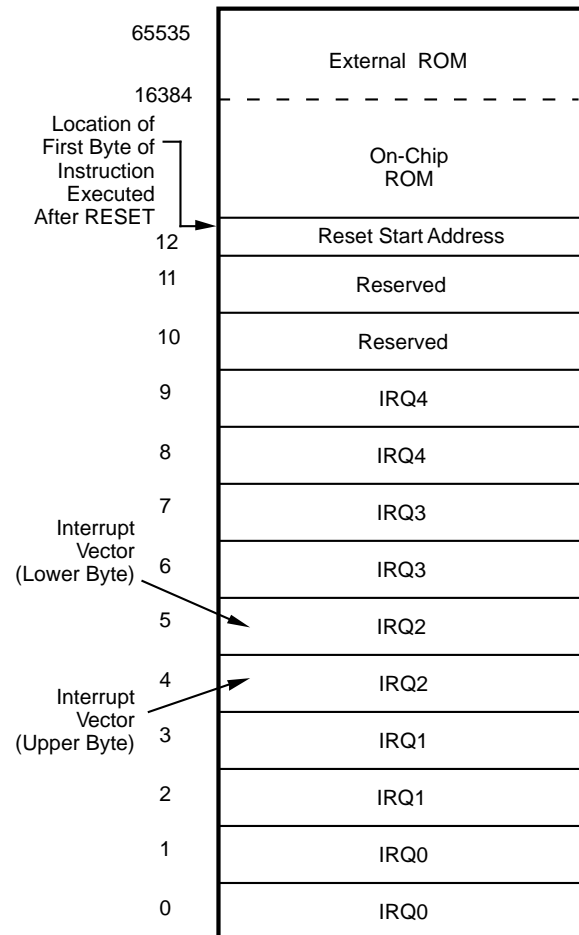
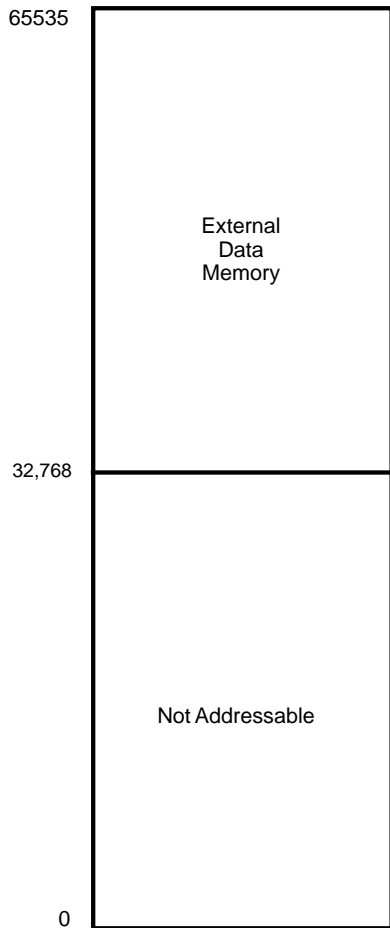


Figure 20. Program Memory Map

**FUNCTIONAL DESCRIPTION** (Continued)



**Figure 21. External Memory Map**

**External Memory.** The Z86E72/73 addresses up to 32 Kbytes (minus FD00H-FFFFH) of External Memory beginning at address 8000H (32K+1), (Figure 27). External data memory is included with, or separated from, the external program memory space. /DM, an optional I/O function that is programmed to appear on P34, is used to distinguish between data and program memory space. The state of the /DM signal is controlled by the type of instruction being executed. An LDC opcode references PROGRAM (/DM inactive) memory, and an LDE instruction references data (/DM active Low) memory.

**Expanded Register File.** The register file has been expanded to allow for additional system control registers, and for mapping of additional peripheral devices into the register address area. The Z8 register address space R0 through R15 has been implemented as 16 banks of 16 registers per bank. These register groups are known as the ERF (Expanded Register File).

Bits 7-4 of register RP select the working register group. Bits 3-0 of register RP select the expanded register file bank. Note that expanded register bank is also referred to as expanded register group (Figure 24).

The upper nibble of the register pointer (Figure 24) selects which working register group of 16 bytes in the register file, out of the possible 256, will be accessed. The lower nibble selects the expanded register file bank and, in the case of the Z86LXX family, banks 0, F, and D are implemented. A 0h in the lower nibble will allow the normal register file (bank 0) to be addressed, but any other value from 1h to Fh will exchange the lower 16 registers to an expanded register bank.

For example:  
Z86E73: (See Figure 23)

R253 RP = 00H  
R0 = Port0  
R1 = Port1  
R2 = Port2  
R3 = Port3

But if:

R253 RP = 0DH  
R0 = CTRL0  
R1 = CTRL1  
R2 = CTRL2  
R3 = Reserved

The counter/timers are mapped into ERF group D. Access is easily done using the following example:

LD RP,#0DH	Select ERF D for access and register Bank 0 as the working register group.
LD R0,#xx	access CTRL0
LD 1,#xx	access CTRL1
LD RP,#7DH	Select expanded register group (ERF) group D for access and register Bank 7 as the working register bank.
LD R1,2	CTRL2 → register 71H

Z8® STANDARD CONTROL REGISTERS

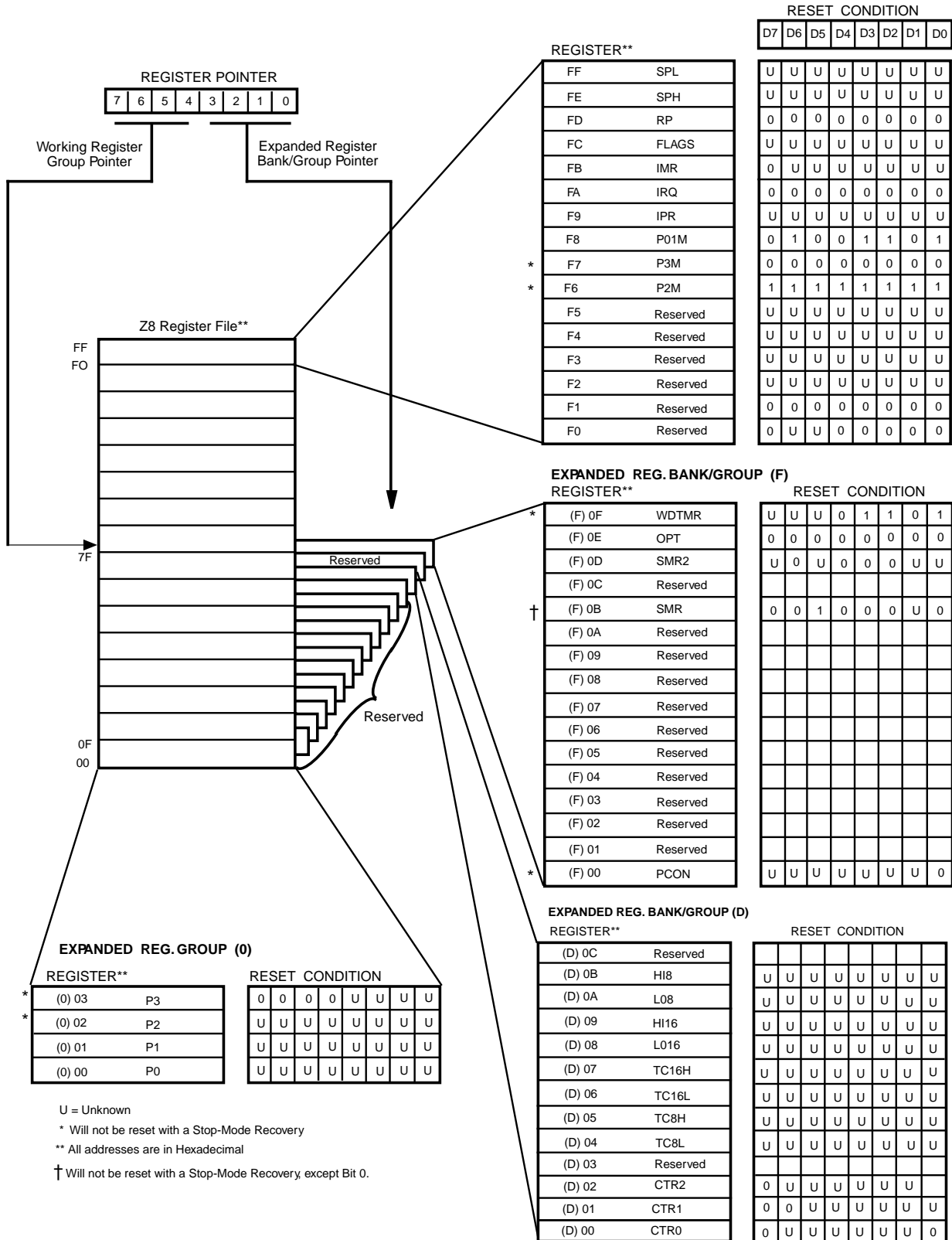


Figure 22. Expanded Register File Architecture

FUNCTIONAL DESCRIPTION (Continued)

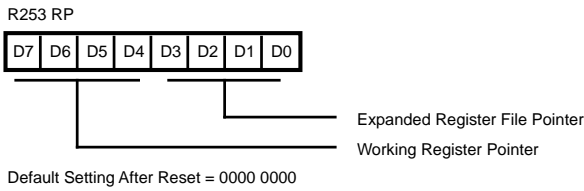


Figure 23. Register Pointer

**Register File.** The register file (bank 0) consists of four I/O port registers, 236 general-purpose registers, and 16 control and status registers (R0-R3, R4-R239, and R240-R255, respectively), Plus two expanded registers groups (Banks D and F). Instructions can access registers directly or indirectly through an 8-bit address field. This allows a short, 4-bit register address using the Register Pointer (Figure 23). In the 4-bit mode, the register file is divided into 16 working register groups, each occupying 16 continuous locations. The Register Pointer addresses the starting location of the active working register group.

**Note:** Working register group E0-EF of Bank 0 are only accessed through working registers and indirect addressing modes.

**Stack.** The Z86E7X external data memory or the internal register file is used for the stack. An 8-bit Stack Pointer (R255) is used for the internal stack that resides in the general-purpose registers (R4-R239). SPH is used as a general-purpose register only when using internal stacks.

**Note:** When SPH is used as a general-purpose register and Port 0 is in address mode, the contents of SPH will be loaded into Port 0 whenever the internal stack is accessed.

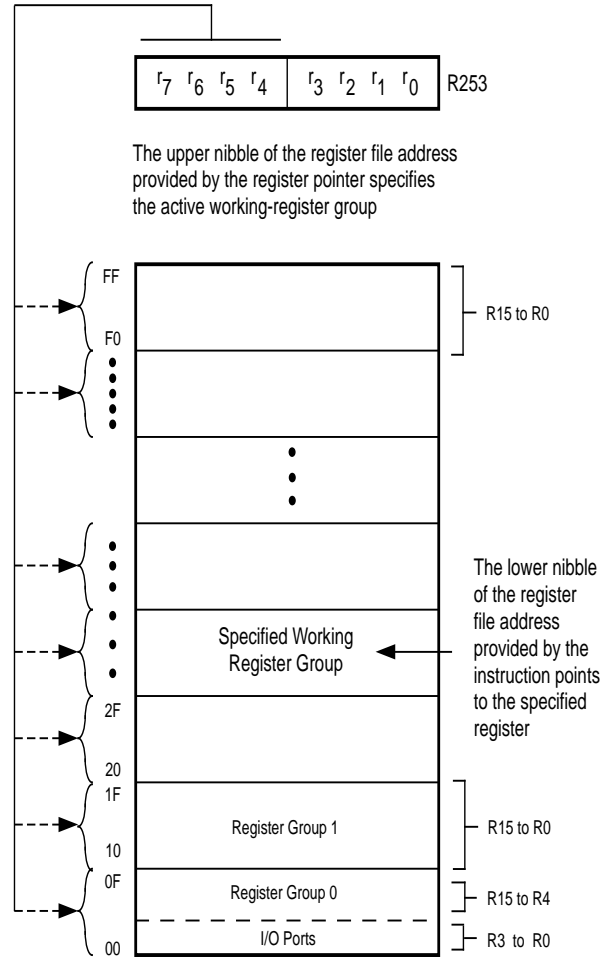


Figure 24. Register Pointer

**COUNTER/TIMER REGISTER DESCRIPTION**
**Table 5. Expanded Register Group D**

(D) %0C	Reserved
(D) % 0B	HI8
(D) % 0A	LO8
(D) %09	HI16
(D) %08	LO16
(D) %07	TC16H
(D) %06	TC16L
(D) %05	TC8H
(D) %04	TC8L
(D) %03	Reserved
(D) %02	CTR2
(D) %01	CTR1
(D) %00	CTR0

**Register Description**

**HI8(D)%0B:** Holds the captured data from the output of the 8-bit Counter/Timer0. This register is typically used to hold the number of counts when the input signal is 1.

Field	Bit Position	Value	Description
T8_Capture_HI	76543210	R/W	Captured Data No Effect

**LO8(D)%0A:** Holds the captured data from the output of the 8-bit Counter/Timer0. This register is typically used to hold the number of counts when the input signal is 0.

Field	Bit Position	Value	Description
T8_Capture_LO	76543210	R/W	Captured Data No Effect

**HI16(D)%09:** Holds the captured data from the output of the 16-bit Counter/Timer16. This register holds the MS-Byte of the data.

Field	Bit Position	Value	Description
T16_Capture_HI	76543210	R/W	Captured Data No Effect

**L016(D)%08:** Holds the captured data from the output of the 16-bit Counter/Timer16. This register holds the LS-Byte of the data.

Field	Bit Position	Value	Description
T16_Capture_LO	76543210	R/W	Captured Data No Effect

**TC16H(D)%07:** Counter/Timer2 MS-Byte Hold Register.

Field	Bit Position	Value	Description
T16_Data_HI	76543210	R/W	Data

**TC16L(D)%06:** Counter/Timer2 LS-Byte Hold Register.

Field	Bit Position	Value	Description
T16_Data_LO	76543210	R/W	Data

**TC8H(D)%05:** Counter/Timer8 High Hold Register.

Field	Bit Position	Value	Description
T8_Level_HI	76543210	R/W	Data

**TC8L(D)%04:** Counter/Timer8 Low Hold Register.

Field	Bit Position	Value	Description
T8_Level_LO	76543210	R/W	Data

## COUNTER/TIMER REGISTER DESCRIPTION (Continued)

**CTR0 (D)00:** Counter/Timer8 Control Register.

Field	Bit Position		Value	Description
T8_Enable	7-----	R	0*	Counter Disabled
			1	Counter Enabled
		W	0	Stop Counter
			1	Enable Counter
Single/Modulo	-6-----	R/W	0	Modulo-N
			1	Single Pass
Time_Out	--5-----	R	0	No Counter Time-Out
			1	Counter Time-Out Occurred
		W	0	No Effect
			1	Reset Flag to 0
T8_Clock	---43---	R/W	0 0	SCLK
			0 1	SCLK/2
			1 0	SCLK/4
			1 1	SCLK/8
Capture_INT_MASK	-----2--	R/W	0	Disable Data Capture Int.
			1	Enable Data Capture Int.
Counter_INT_Mask	-----1-	R/W	0	Disable Time-Out Int.
			1	Enable Time-Out Int.
P34_Out	-----0	R/W	0*	P34 as Port Output
			1	T8 Output on P34

**Note:** \*Indicates the value upon Power-On Reset

### CTR0: Counter/Timer8 Control Register Description

**T8 Enable.** This field enables T8 when set (written) to 1.

**Single/Modulo-N.** When set to 0 (modulo-n), the counter reloads the initial value when the terminal count is reached. When set to 1 (single pass), the counter stops when the terminal count is reached.

**Time-Out.** This bit is set when T8 times out (terminal count reached). To reset this bit, a 1 should be written to this location. ***This is the only way to reset this status condition, therefore, care should be taken to reset this bit prior to using/enabling the counter/timers.***

**Note:** Care must be taken when utilizing the OR or AND commands to manipulate CTR0, bit 5 and CTR1, bits 0 and 1 (Demodulation Mode). These instructions use a Read-Modify-Write sequence in which the current status from the CTR0 and CTR1 registers will be ORed or ANDed with the designated value and then written back into the registers. Example: When the status of bit 5 is 1, a reset condition will occur.

**T8 Clock.** Defines the frequency of the input signal to T8.

**Capture\_INT\_Mask.** Set this bit to allow interrupt when data is captured into either LO8 or HI8 upon a positive or negative edge detection in demodulation mode.

**Counter\_INT\_Mask.** Set this bit to allow interrupt when T8 has a time out.

**P34\_Out.** This bit defines whether P34 is used as a normal output pin or the T8 output



**CTR1(D)%01:** Controls the functions in common with the T8 and T16.

Field	Bit Position		Value	Description
Mode	7-----	R/W	0*	Transmit Mode
			1	Demodulation Mode
P36_Out/ Demodulator_Input	-6-----	R/W	0*	Transmit Mode
			1	Port Output
			0	T8/16 Output
			1	Demodulation Mode
T8/T16_Logic/ Edge_Detect	--54----	R/W	0	P31
			1	P20
			0 0	Transmit Mode
			0 1	AND
			1 0	OR
			1 1	NOR
			0 0	NAND
			0 1	Demodulation Mode
			1 0	Falling Edge
			1 1	Rising Edge
Transmit_Submode/ Glitch_Filter	----32--	R/W	1 0	Both Edges
			1 1	Reserved
			0 0	Transmit Mode
			0 1	Normal Operation
			1 0	Ping-Pong Mode
			1 1	T16_OUT = 0
			0 0	T16_OUT = 1
			0 1	Demodulation Mode
Initial_T8_Out/ Rising_Edge	-----1-	R/W	0	No Filter
			1	4 SCLK Cycle
		R	0	8 SCLK Cycle
			1	16 SCLK Cycle
		W	0	Transmit Mode
			1	T8_OUT is 0 Initially
Initial_T16_Out/ Falling_Edge	-----0	R/W	0	T8_OUT is 1 Initially
			1	Demodulation Mode
		R	0	No Rising Edge
			1	Rising Edge Detected
		W	0	No Effect
			1	Reset Flag to 0

**Note:** \* Indicates the value upon Power-On Reset.

## COUNTER/TIMER REGISTER DESCRIPTION (Continued)

### CTR1 Register Description

Mode. If it is 0, the Counter/Timers are in the transmit mode, otherwise they are in the demodulation mode.

**P36\_Out/Demodulator\_Input.** In Transmit Mode, this bit defines whether P36 is used as a normal output pin or the combined output of T8 and T16.

In Demodulation Mode, this bit defines whether the input signal to the Counter/Timers is from P20 or P31.

**T8/T16\_Logic/Edge\_Detect.** In Transmit Mode, this field defines how the outputs of T8 and T16 are combined (AND, OR, NOR, NAND).

In Demodulation Mode, this field defines which edge should be detected by the edge detector.

**Transmit\_Submode/Glitch Filter.** In Transmit Mode, this field defines whether T8 and T16 are in the "Ping-Pong" mode or in independent normal operation mode. Setting this field to "Normal Operation Mode" terminates the "Ping-Pong Mode" operation. When set to 10, T16 is immediately forced to a 0. When set to 11, T16 is immediately forced to a 1.

In Demodulation Mode, this field defines the width of the glitch that should be filtered out.

**Initial\_T8\_Out/Rising\_Edge.** In Transmit Mode, if 0, the output of T8 is set to 0 when it starts to count. If 1, the output of T8 is set to 1 when it starts to count. When this bit is set to 1 or 0, T8\_OUT will be set to the opposite state of this bit. This insures that when the clock is enabled a transition occurs to the initial state set by CTR1, D1.

In Demodulation Mode, this bit is set to 1 when a rising edge is detected in the input signal. In order to reset it, a 1 should be written to this location.

**Initial\_T16 Out/Falling\_Edge.** In Transmit Mode, if it is 0, the output of T16 is set to 0 when it starts to count. If it is 1, the output of T16 is set to 1 when it starts to count. This bit is effective only in Normal or Ping-Pong Mode (CTR1, D3, D2). When this bit is set, T16\_OUT will be set to the opposite state of this bit. This insures that when the clock is enabled a transition occurs to the initial state set by CTR1, D0.

In Demodulation Mode, this bit is set to 1 when a falling edge is detected in the input signal. In order to reset it, a 1 should be written to this location.

**Note:** Modifying CTR1, (D1 or D0) while the counters are enabled will cause un-predictable output from T8/T16 out.

**CTR2 (D)%02:** Counter/Timer16 Control Register.

Field	Bit Position		Value	Description
T16_Enable	7-----	R	0*	Counter Disabled
			1	Counter Enabled
		W	0	Stop Counter
			1	Enable Counter
Submode/Modulo-N	-6-----	R/W		Transmit Mode
			0	Modulo-N
			1	Single Pass
				Demodulation Mode
			0	T16 Recognizes Edge
Time_Out	--5-----	R	0	No Counter Time-Out
			1	Counter Time-Out Occurred
		W	0	No Effect
			1	Reset Flag to 0
T16_Clock	---43---	R/W	00	SCLK
			01	SCLK/2
			10	SCLK/4
			11	SCLK/8
Capture_INT_Mask	-----2--	R/W	0	Disable Data Capture Int.
			1	Enable Data Capture Int.
Counter_INT_Mask	-----1-	R/W	0	Disable Time-Out Int.
			1	Enable Time-Out Int.
P35_Out	-----0	R/W	0*	P35 as Port Output
			1	T16 Output on P35

**Note:** \* Indicates the value upon Power-On Reset.

### CTR2 Description

**T16\_Enable.** This field enables T16 when set to 1.

Single/Modulo-N. In Transmit Mode, when set to 0, the counter reloads the initial value when terminal count is reached. When set to 1, the counter stops when the terminal count is reached.

In Demodulation Mode, when set to 0, T16 captures and reloads on detection of all the edges; when set to 1, T16 captures and detects on the first edge, but ignores the subsequent edges. For details, see the description of T16 Demodulation Mode.

**Time\_Out.** This bit is set when T16 times out (terminal count reached). In order to reset it, a 1 should be written to this location.

**T16\_Clock.** Defines the frequency of the input signal to Counter/Timer16.

**Capture\_INT\_Mask.** Set this bit to allow interrupt when data is captured into LO16 and HI16.

**Counter\_INT\_Mask.** Set this bit to allow interrupt when T16 times out.

**P35\_Out.** This bit defines whether P35 is used as a normal output pin or T16 output.

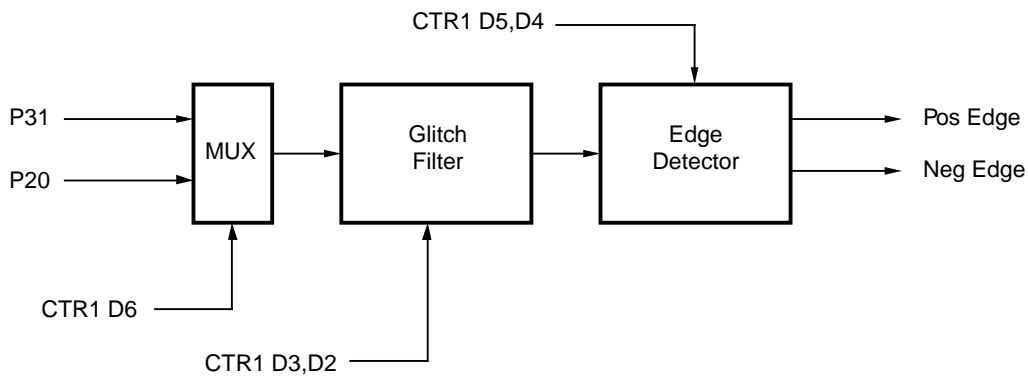
## COUNTER/TIMER REGISTER DESCRIPTION (Continued)

**SMR2(F) %0D:** Stop-Mode Recovery Register 2.

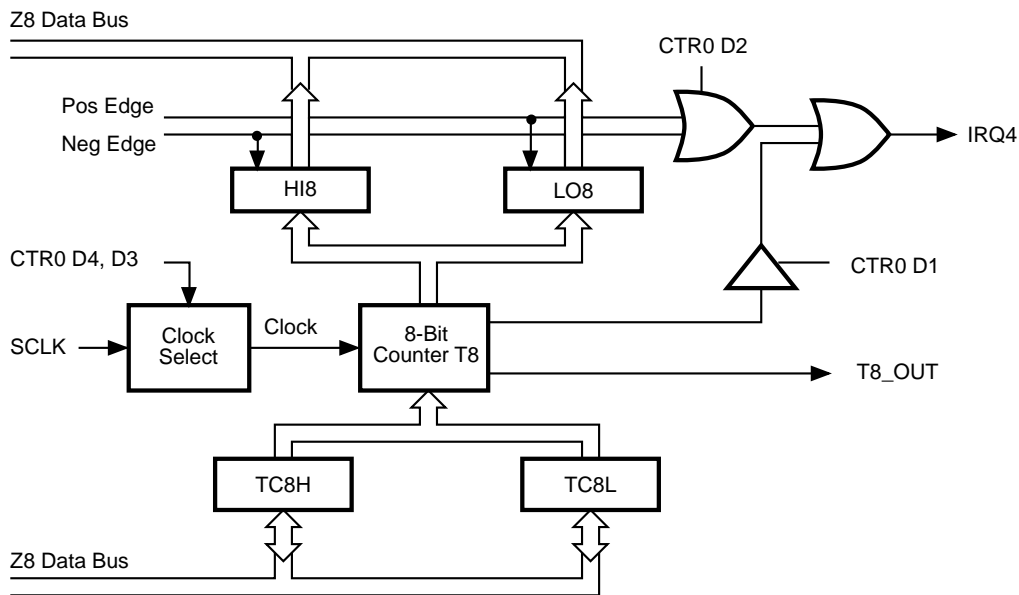
Field	Bit Position		Value	Description
Reserved	7-----		0	Reserved (Must be 0)
Recovery Level	-6-----	W	0*	Low
			1	High
Reserved	--5-----		0	Reserved (Must be 0)
Source	---432--	W	000*	A. POR Only
			001	B. NAND of P23-P20
			010	C. NAND or P27-P20
			011	D. NOR of P33-P31
			100	E. NAND of P33-P31
			101	F. NOR of P33-P31, P00,P07
			110	G. NAND of P33-P31,P00,P07
			111	H. NAND of P33-P31,P22-P20
Reserved	-----10		00	Reserved (Must be 0)

**Note:** \* Indicates the value upon Power-On Reset.

### Counter/Timer Functional Blocks



**Figure 25. Glitch Filter Circuitry**



**Figure 26. 8-Bit Counter/Timer Circuits**

### Input Circuit

The edge detector monitors the input signal on P31 or P20. Based on CTR1 D5-D4, a pulse is generated at the Pos Edge or Neg Edge line when an edge is detected. Glitches in the input signal which have a width less than specified (CTR1 D3, D2) are filtered out.

### T8 Transmit Mode

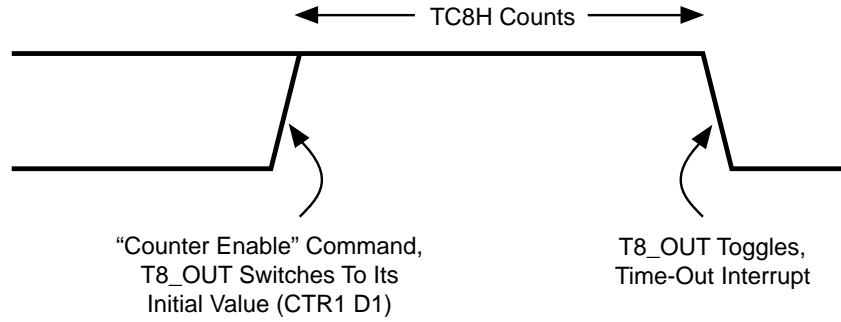
When T8 is enabled, the output of T8 depends on CTR1, D1. If it is 0, T8\_OUT is 1. If it is 1, T8\_OUT is 0.

When T8 is enabled, the output T8\_OUT switches to the initial value (CTR1 D1). If the initial value (CTR1 D1) is 0, TC8L is loaded, otherwise TC8H is loaded into the counter. In Single-Pass Mode (CTR0 D6), T8 counts down to 0 and stops, T8\_OUT toggles, the time-out status bit (CTR0 D5) is set, and a time-out interrupt can be generated if it is enabled (CTR0 D1) (Figure 33). In Modulo-N Mode, upon reaching terminal count, T8\_OUT is toggled, but no interrupt is generated. Then T8 loads a new count (if the T8\_OUT level now is 0, TC8L is loaded; if it is 1, TC8H is loaded). T8 counts down to 0, toggles T8\_OUT, sets the time-out status bit (CTR0 D5) and generates an interrupt if enabled (CTR0 D1) (Figure 34). This completes one cycle. T8 then loads from TC8H or TC8L according to the T8\_OUT level, and repeats the cycle.

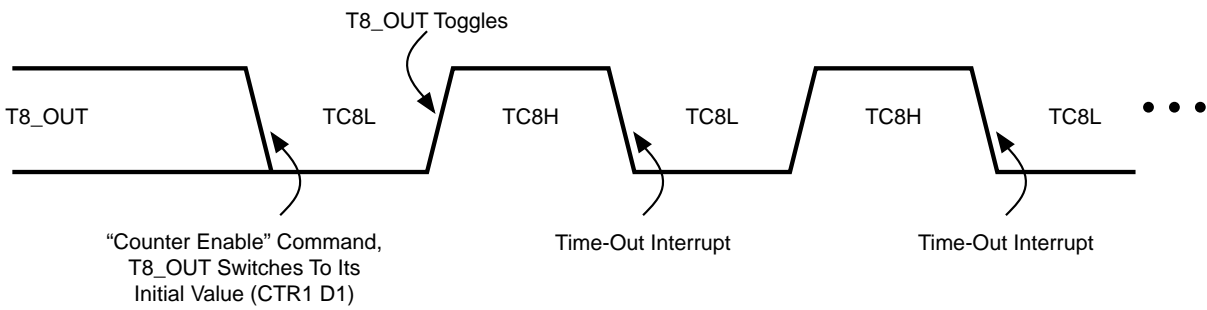
The user can modify the values in TC8H or TC8L at any time. The new values take effect when they are loaded. Care must be taken not to write these registers at the time the values are to be loaded into the counter/timer, to ensure known operation. An initial count of 1 is not allowed (a non-function will occur). An initial count of 0 will cause TC8 to count from 0 to %FF to %FE (Note, % is used for hexadecimal values). Transition from 0 to %FF is not a time-out condition.

**Note: Using the same instructions for stopping the counter/timers and setting the status bits is not recommended.** Two successive commands, first stopping the counter/timers, then resetting the status bits is necessary. This is required because it takes one counter/timer clock interval for the initiated event to actually occur.

### COUNTER/TIMER REGISTER DESCRIPTION (Continued)



**Figure 27. T8\_OUT in Single-Pass Mode**



**Figure 28. T8\_OUT in Modulo-N Mode**

### T8 Demodulation Mode

The user should program TC8L and TC8H to %FF. After T8 is enabled, when the first edge (rising, falling, or both depending on CTR1 D5, D4) is detected, it starts to count down. When a subsequent edge (rising, falling, or both depending on CTR1 D5, D4) is detected during counting, the current value of T8 is one's complemented and put into one of the capture registers. If it is a positive edge, data is

put into LO8, if negative edge, HI8. One of the edge detect status bits (CTR1 D1, D0) is set, and an interrupt can be generated if enabled (CTR0 D2). Meanwhile, T8 is loaded with %FF and starts counting again. Should T8 reach 0, the time-out status bit (CTR0 D5) is set, an interrupt can be generated if enabled (CTR0 D1), and T8 continues counting from %FF (Figure 35).

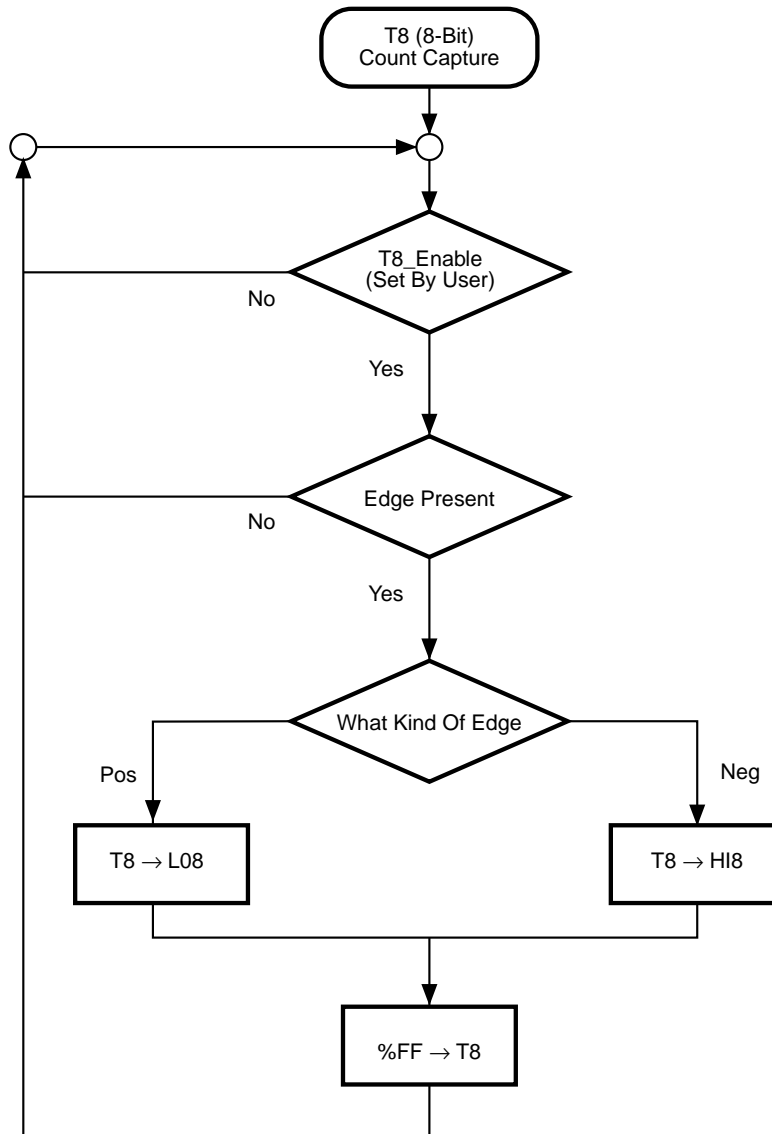


Figure 29. Demodulation Mode Count Capture Flowchart

COUNTER/TIMER REGISTER DESCRIPTION (Continued)

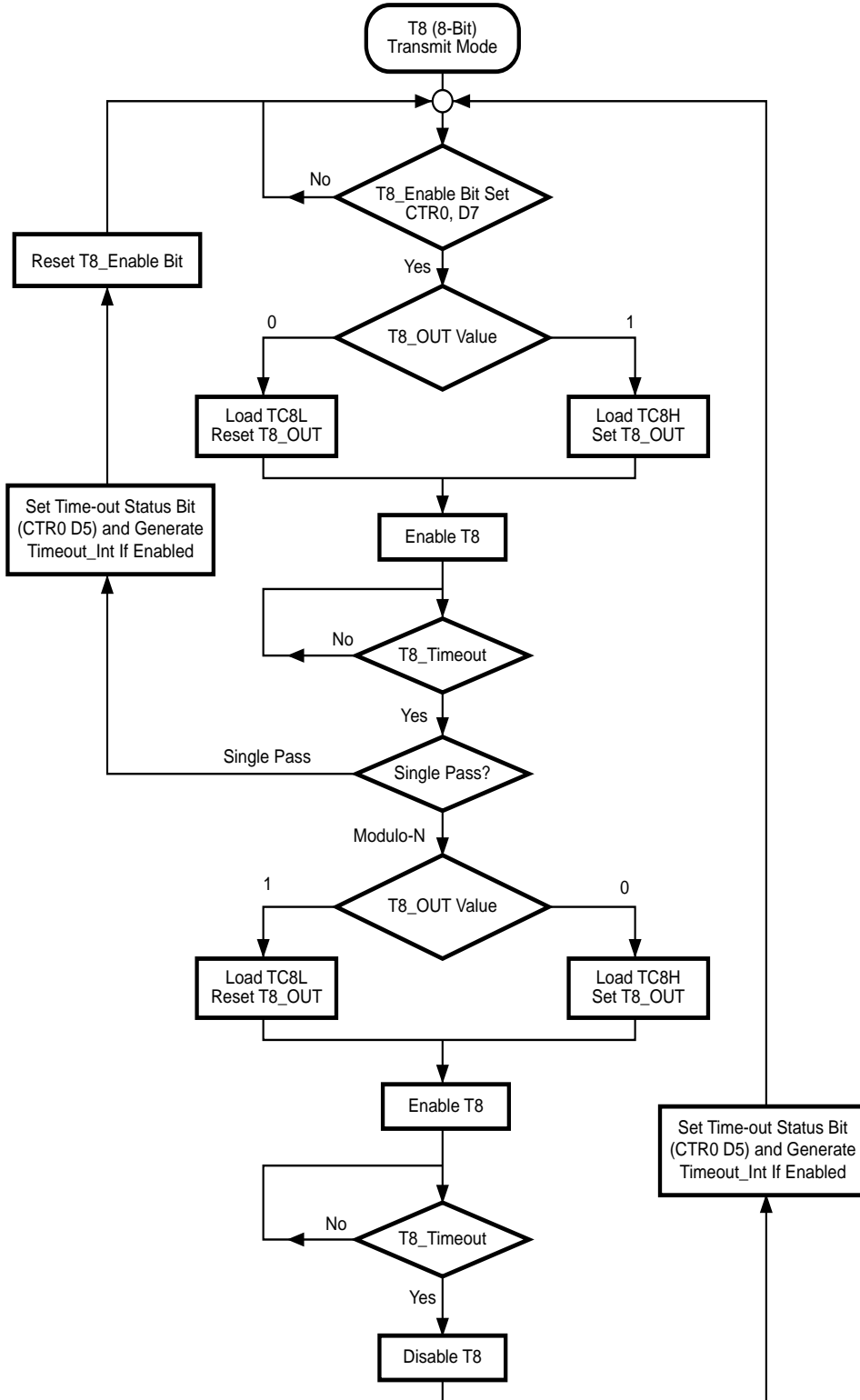


Figure 30. Transmit Mode Flowchart



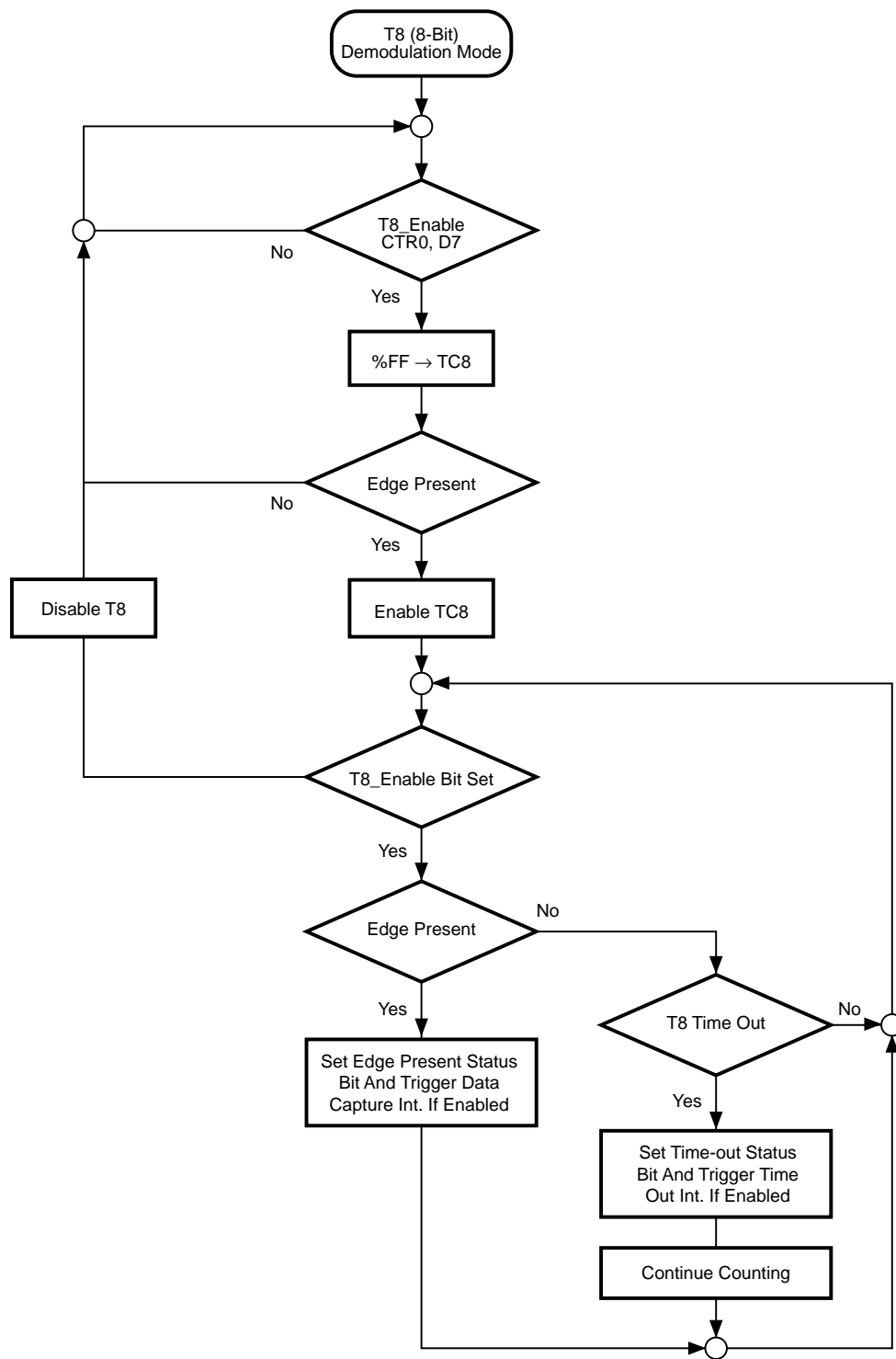


Figure 31. Demodulation Mode Flowchart

COUNTER/TIMER REGISTER DESCRIPTION (Continued)

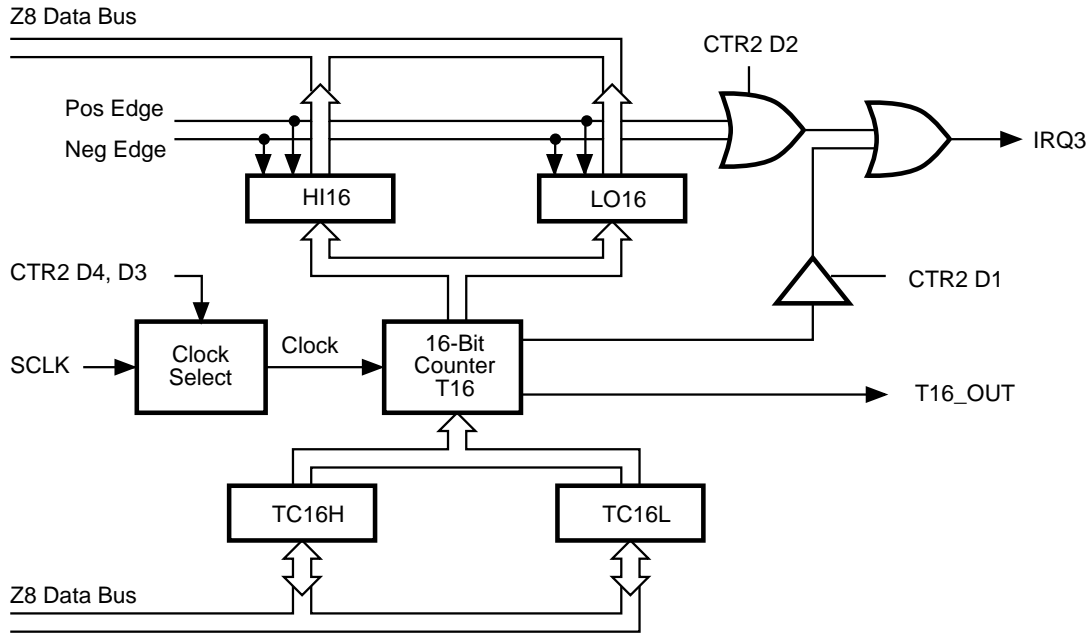


Figure 32. 16-Bit Counter/Timer Circuits

**T16 Transmit Mode**

In Normal or Ping-Pong Mode, the output of T16 when not enabled is dependent on CTR1, D0. If it is a 0, T16\_OUT is a 1; if it is a 1, T16\_OUT is 0. The user can force the output of T16 to either a 0 or 1 whether it is enabled or not by programming CTR1 D3, D2 to a 10 or 11.

When T16 is enabled, TC16H \* 256 + TC16L is loaded, and T16\_OUT is switched to its initial value (CTR1 D0). When T16 counts down to 0, T16\_OUT is toggled (in Normal or Ping-Pong Mode), an interrupt is generated if enabled (CTR2 D1), and a status bit (CTR2 D5) is set. Note that global interrupts will override this function as described in the interrupts section. If T16 is in Single-Pass Mode, it is stopped at this point. If it is in Modulo-N Mode, it is loaded with TC16H \* 256 + TC16L and the counting continues.

The user can modify the values in TC16H and TC16L at any time. The new values take effect when they are loaded. Care must be taken not to load these registers at the time the values are to be loaded into the counter/timer, to ensure known operation. An initial count of 1 is not allowed. An initial count of 0 will cause T16 to count from 0 to %FF FF to %FFFE. Transition from 0 to %FFFF is not a time-out condition.

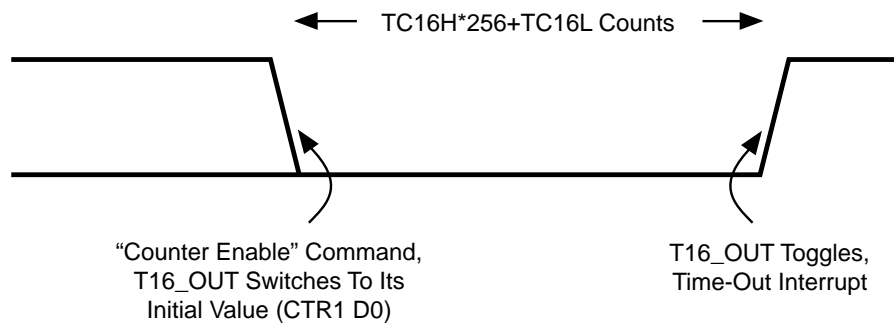


Figure 33. T16\_OUT in Single-Pass Mode

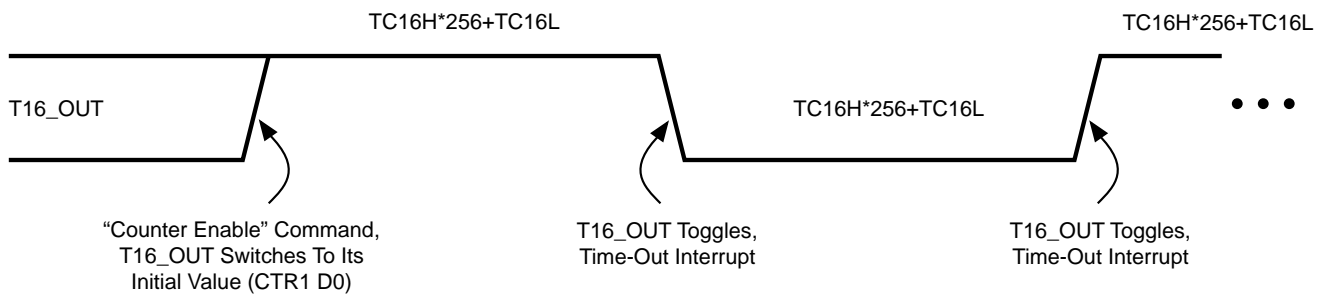


Figure 34. T16\_OUT in Modulo-N Mode

### T16 Demodulation Mode

The user should program TC16L and TC16H to %FF. After T16 is enabled, when the first edge (rising, falling or both depending on CTR1, D5, D4) is detected. T16 captures HI16 and LO16, reloads and begins counting.

**If D6 of CTR2 is 0:** When a subsequent edge (rising, falling, or both depending on CTR1 D5, D4) is detected during counting, the current count in T16 is one's complemented and put into HI16 and LO16. When data is captured, one of the edge detect status bits (CTR1 D1, D0) is set and an interrupt is generated if enabled (CTR2 D2). T16 is loaded with %FFFF and starts again.

**If D6 of CTR2 is 1:** T16 ignores the subsequent edges in the input signal and continues counting down. A time out of T8 will cause T16 to capture its current value and generate an interrupt if enabled (CTR2, D2). In this case, T16 does not reload and continues counting. If D6 bit of CTR2 is toggled (by writing a 0 then a 1 to it), T16 will capture and reload on the next edge (rising, falling, or both depending on CTR1 D5, D4) but continue to ignore subsequent edges.

Should T16 reach 0, it continues counting from %FFFF; meanwhile, a status bit (CTR2 D5) is set and an interrupt time-out can be generated if enabled (CTR2 D1).

## COUNTER/TIMER REGISTER DESCRIPTION (Continued)

### Ping-Pong Mode

This operation mode is only valid in Transmit Mode. T8 and T16 need to be programmed in Single-Pass Mode (CTR0 D6, CTR2 D6) and Ping-Pong Mode needs to be programmed in CTR1 D3, D2. The user can begin the operation by enabling either T8 or T16 (CTR0 D7 or CTR2 D7). For example, if T8 is enabled, T8\_OUT is set to this initial value (CTR1 D1). According to T8\_OUT's level, TC8H or TC8L is loaded into T8. After the terminal count is reached, T8 is disabled and T16 is enabled. T16\_OUT switches to its initial value (CTR1 D0), data from TC16H

and TC16L is loaded, and T16 starts to count. After T16 reaches the terminal count it stops, T8 is enabled again, and the whole cycle repeats. Interrupts can be allowed when T8 or T16 reaches terminal control (CTR0 D1, CTR2 D1). To stop the Ping-Pong operation, write 00 to bits D3 and D2 of CTR1.

**Note: Enabling Ping-Pong operation while the counter/timers are running may cause intermittent counter/timer function.** Disable the counter/timers, then reset the status flags prior to instituting this operation.

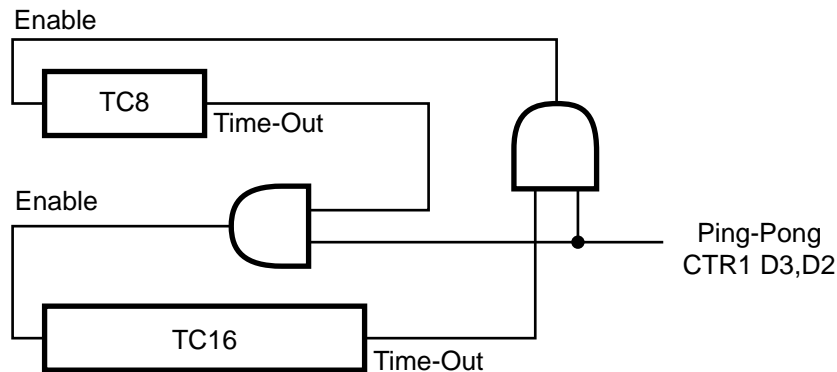


Figure 35. Ping-Pong Mode

### To Initiate Ping-Pong Mode

First, make sure both counter/timers are not running. Then set T8 into Single-Pass Mode (CTR0 D6), set T16 into Single-Pass Mode (CTR2 D6), and set Ping-Pong Mode (CTR1 D2, D3). These instructions do not have to be in any particular order. Finally, start Ping-Pong Mode by enabling either T8 (CTR0 D7) or T16 (CTR2 D7).

### During Ping-Pong Mode

The enable bits of T8 and T16 (CTR0 D7, CTR2 D7) will alternately be set and cleared by hardware. The time-out bits (CTR0 D5, CTR2 D5) will be set every time the counter/timers reach the terminal count.

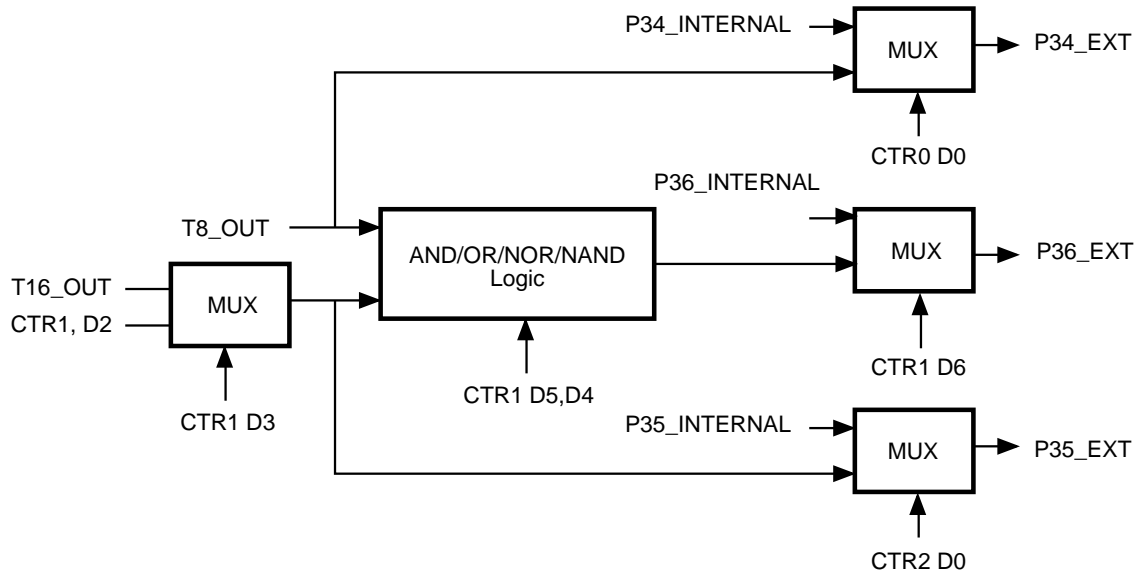


Figure 36. Output Circuit

## COUNTER/TIMER REGISTER DESCRIPTION (Continued)

**Interrupts.** The Z86E7X has five different interrupts. The interrupts are maskable and prioritized (Figure 42). The five sources are divided as follows: three sources are claimed by Port 3 lines P33-P31, the remaining two by the

counter/timers (Table 10). The Interrupt Mask Register globally or individually enables or disables the five interrupt requests.

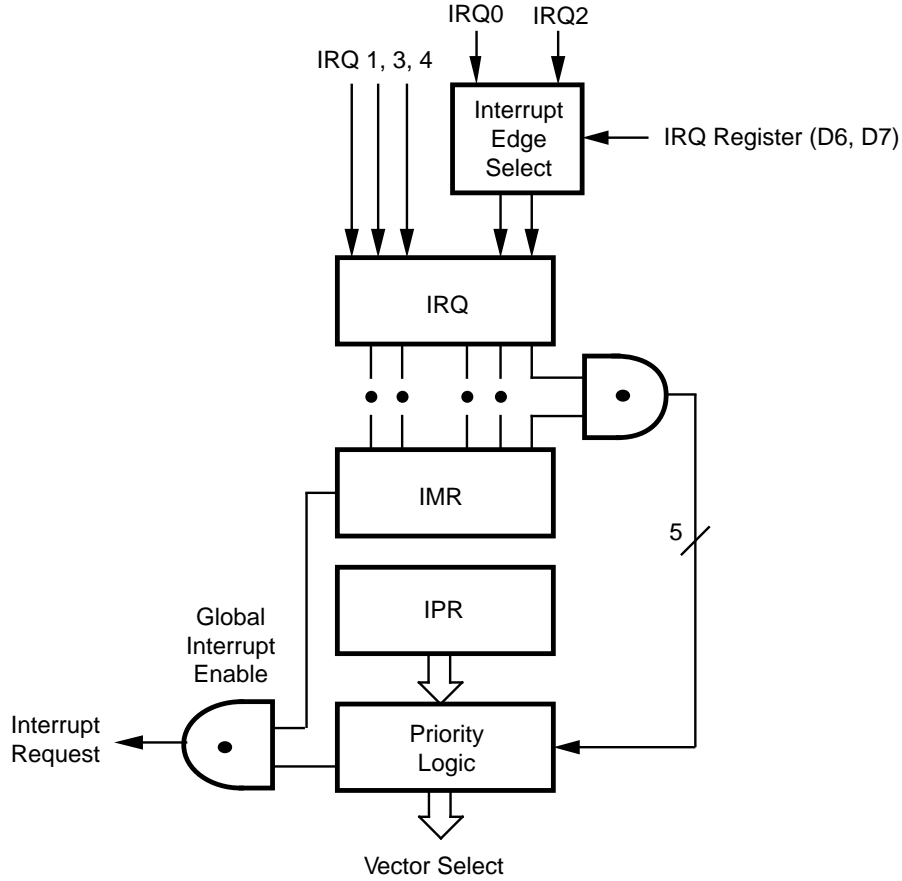


Figure 37. Interrupt Block Diagram

**Table 6. Interrupt Types, Sources, and Vectors**

Name	Source	Vector Location	Comments
IRQ0	/DAV0, IRQ0	0, 1	External (P32), Rising Falling Edge Triggered
IRQ1,	IRQ1	2, 3	External (P33), Falling Edge Triggered
IRQ2	/DAV2, IRQ2, T <sub>IN</sub>	4,5	External (P31), Rising Falling Edge Triggered
IRQ3	T16	6, 7	Internal
IRQ4	T8	8, 9	Internal

When more than one interrupt is pending, priorities are resolved by a programmable priority encoder controlled by the Interrupt Priority register. An interrupt machine cycle is activated when an interrupt request is granted. This disables all subsequent interrupts, saves the Program Counter and Status Flags, and then branches to the program memory vector location reserved for that interrupt. All Z86E7X interrupts are vectored through locations in the program memory. This memory location and the next byte contain the 16-bit address of the interrupt service routine for that particular interrupt request. To accommodate polled interrupt systems, interrupt inputs are masked and the Interrupt Request register is polled to determine which of the interrupt requests need service.

An interrupt resulting from AN1 is mapped into IRQ2, and an interrupt from AN2 is mapped into IRQ0. Interrupts IRQ2 and IRQ0 may be rising, falling, or both edge triggered, and are programmable by the user. The software can poll to identify the state of the pin.

Programming bits for the Interrupt Edge Select are located in the IRQ Register (R250), bits D7 and D6. The configuration is shown in Table 11.

**Table 7. IRQ Register**

IRQ		Interrupt Edge	
D7	D6	IRQ2 (P31)	IRQ0 (P32)
0	0	F	F
0	1	F	R
1	0	F	F
1	1	R/F	R/F

**Notes:**

F = Falling Edge

R = Rising Edge

In analog mode, the Stop-Mode Recovery sources selected by the SMR register are connected to the IRQ1 input. Any of the Stop-Mode Recovery sources for SMR (except P31, P32, and P33) can be used to generate IRQ1 (falling edge triggered).

**Clock.** The Z86E7X on-chip oscillator has a high-gain, parallel-resonant amplifier for connection to a crystal, LC, ceramic resonator, or any suitable external clock source (XTAL1 = Input, XTAL2 = Output). The crystal should be AT cut, 1 MHz to 8 MHz maximum, with a series resistance (RS) less than or equal to 100 Ohms. The Z86L7X on-chip oscillator may be driven with a cost-effective RC network or other suitable external clock source.

The crystal should be connected across XTAL1 and XTAL2 using the recommended capacitors (capacitance greater than or equal to 22 pF) from each pin to ground. The RC oscillator configuration is an external resistor connected from XTAL1 to XTAL2, with a frequency-setting capacitor from XTAL1 to ground (Figure 44).

## COUNTER/TIMER REGISTER DESCRIPTION (Continued)

**Power-On Reset (POR).** A timer circuit clocked by a dedicated on-board RC oscillator is used for the Power-On Reset (POR) timer function. The POR time allows VCC and the oscillator circuit to stabilize before instruction execution begins.

The POR timer circuit is a one-shot timer triggered by one of three conditions:

1. Power Fail to Power OK status.
2. Stop-Mode Recovery (if D5 of SMR = 1).
3. WDT Time-Out.

The POR time is a nominal 5 ms. Bit 5 of the Stop-Mode Register determines whether the POR timer is bypassed after Stop-Mode Recovery (typical for external clock, RC, LC oscillators).

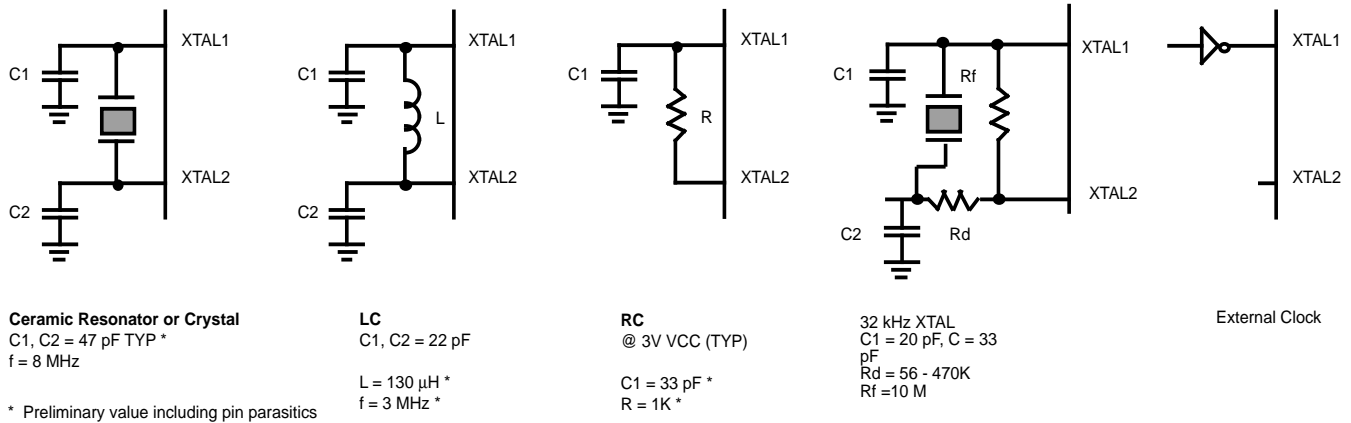


Figure 38. Oscillator Configuration



**HALT.** HALT turns off the internal CPU clock, but not the XTAL oscillation. The counter/timers and external interrupts IRQ0, IRQ1, IRQ2, IRQ3, and IRQ4 remain active. The devices are recovered by interrupts, either externally or internally generated. An interrupt request must be executed (enabled) to exit HALT mode. After the interrupt service routine, the program continues from the instruction after the HALT.

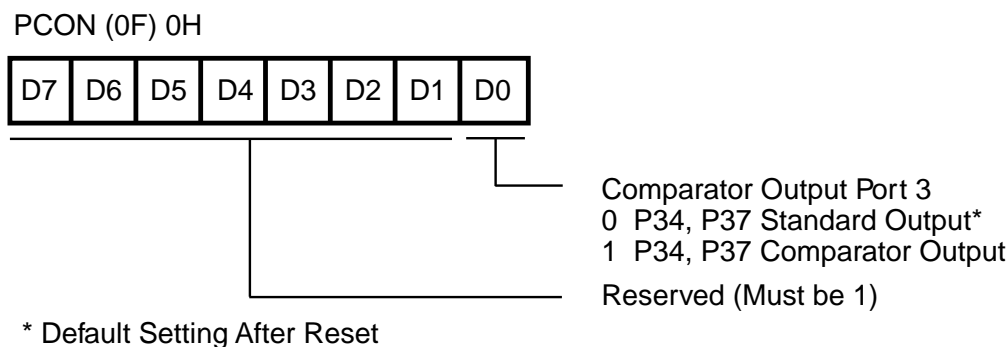
**STOP.** This instruction turns off the internal clock and external crystal oscillation and reduces the standby current to 10  $\mu$ A (typical) or less. STOP mode is terminated only by a reset, such as WDT time-out, POR, SMR, or external reset. This causes the processor to restart the application program at address 000CH. In order to enter STOP (or

HALT) mode, it is necessary to first flush the instruction pipeline to avoid suspending execution in mid-instruction. To do this, the user must execute a NOP (opcode = FFH) immediately before the appropriate sleep instruction, i.e.,

```

FF  NOP    ; clear the pipeline
6F  STOP   ; enter STOP mode
    or
FF  NOP    ; clear the pipeline
7F  HALT   ; enter HALT mode
    
```

**Port Configuration Register (PCON).** The PCON register configures the comparator output on Port 3. It is located in the expanded register file at Bank F, location 00 (Figure 44).



**Figure 39. Port Configuration Register (PCON)**  
**(Write Only)**

**Comparator Output Port 3 (D0).** Bit 0 controls the comparator used in Port 3. A 1 in this location brings the comparator outputs to P34 and P37, and a 0 releases the Port to its standard I/O configuration.

**Stop-Mode Recovery Register (SMR).** This register selects the clock divide value and determines the mode of Stop-Mode Recovery (Figure 46). All bits are write only except bit 7, which is read only. Bit 7 is a flag bit that is hardware set on the condition of STOP recovery and reset by a power-on cycle. Bit 6 controls whether a low level or a high level is required from the recovery source. Bit 5 controls the reset delay after recovery. Bits D2, D3, and D4, of the SMR register, specify the source of the Stop-Mode Recovery signal. Bit D0 determines if SCLK/TCLK are divided by 16 or not. The SMR is located in Bank F of the Expanded Register Group at address 0BH

COUNTER/TIMER REGISTER DESCRIPTION (Continued)

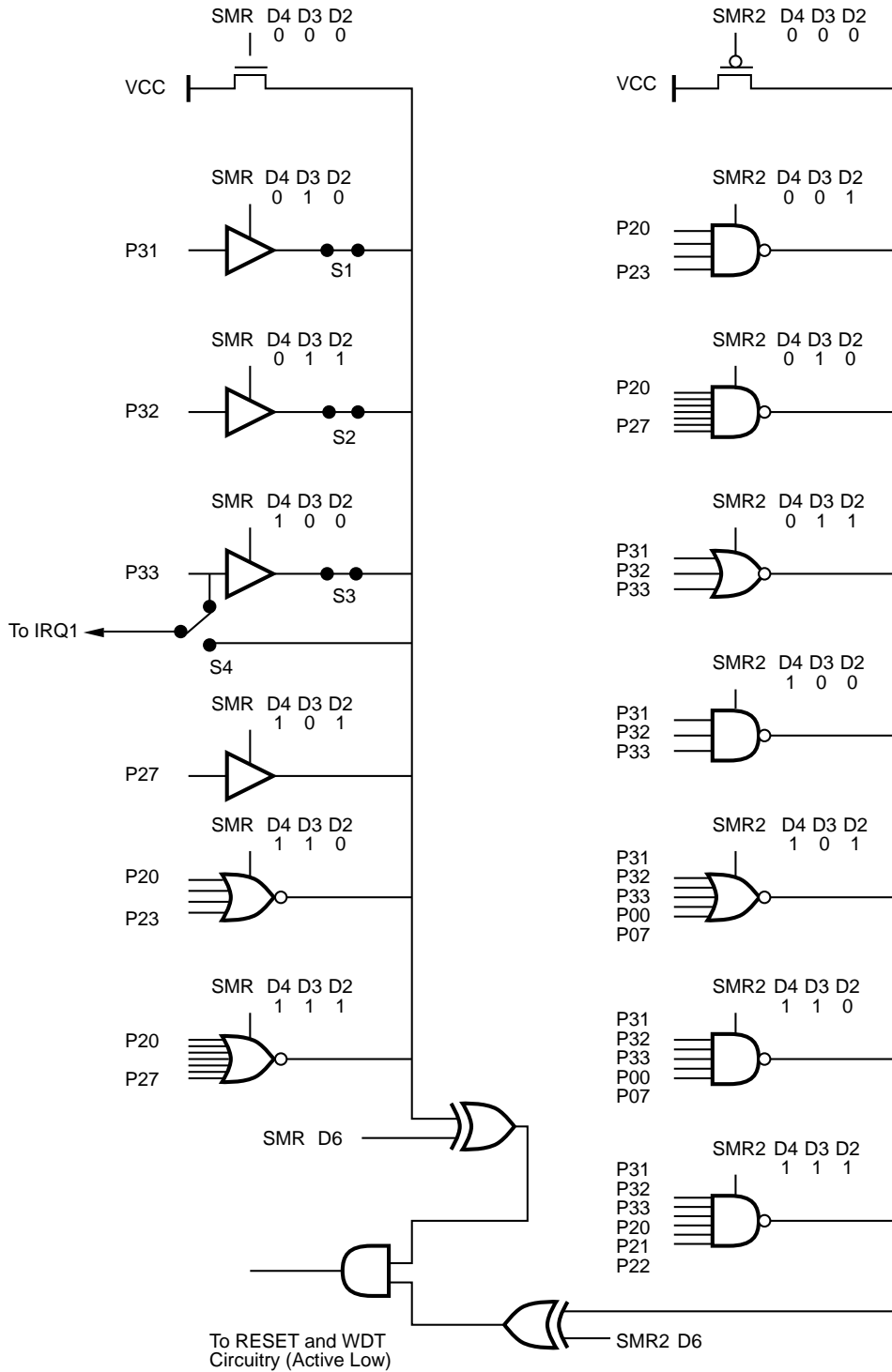


Figure 40. Stop-Mode Recovery Register

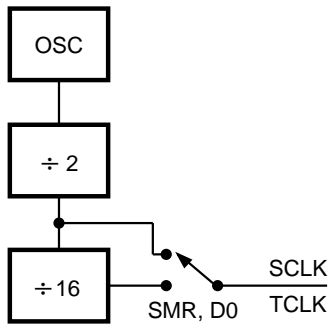


Figure 41. SCLK Circuit

**SCLK/TCLK Divide-by-16 Select (D0).** D0 of the SMR controls a Divide-by-16 prescaler of SCLK/TCLK. The purpose of this control is to selectively reduce device power consumption during normal processor execution (SCLK control) and/or HALT mode (where TCLK sources interrupt logic). After Stop-Mode Recovery, this bit is set to a 0.

**Stop-Mode Recovery Source (D2, D3, and D4).** These three bits of the SMR specify the wake up source of the STOP recovery (Figure 49 and Table 12).

Table 8. Stop-Mode Recovery Source

SMR:432			Operation
D4	D3	D2	Description of Action
0	0	0	POR and/or external reset recovery
0	0	1	Reserved P27 transition Logical NOR of P20 through P23 Logical NOR of P20 through P27
0	1	0	
0	1	1	
1	0	0	
1	0	1	
1	1	0	
1	1	1	

**Note:** Any Port 2 bit defined as an output will drive the corresponding input to the default state to allow the remaining inputs to control the AND/OR function. Refer to SMR2 register for other recover sources.

**Stop-Mode Recovery Delay Select (D5).** This bit, if low, disables the 5 ms /RESET delay after Stop-Mode Recovery. The default configuration of this bit is one. If the "fast" wake up is selected, the Stop-Mode Recovery source needs to be kept active for at least 5TpC.

**Stop-Mode Recovery Edge Select (D6).** A 1 in this bit position indicates that a High level on any one of the recovery sources wakes the Z86E7X from STOP mode. A 0 indicates Low level recovery. The default is 0 on POR (Figure 36).

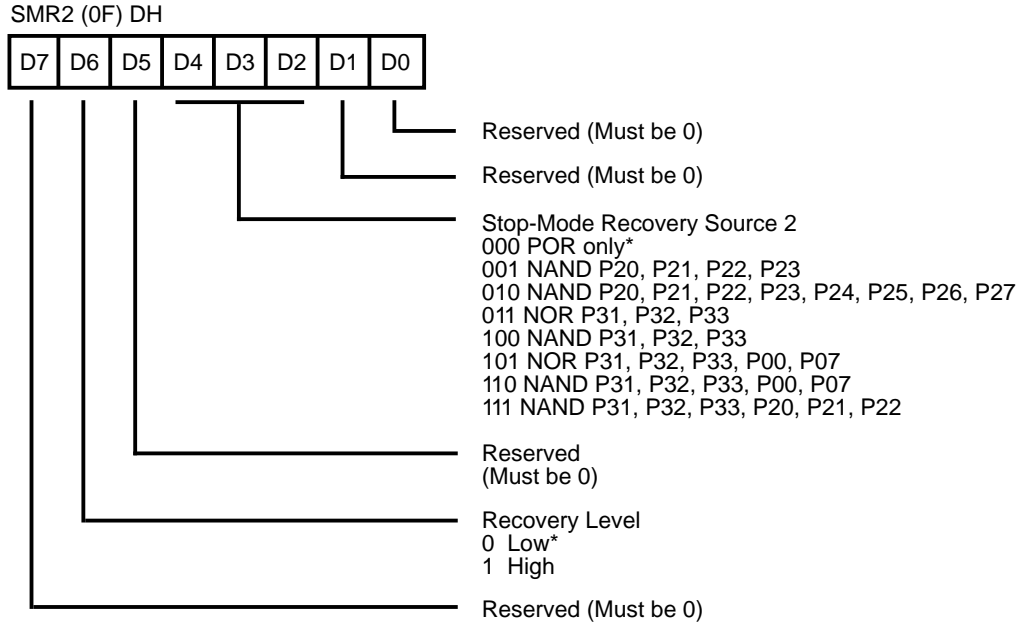
**Cold or Warm Start (D7).** This bit is set by the device upon entering STOP mode. It is a Read Only Flag bit. A 1 in D7 (warm) indicates that the device will awaken from a SMR source or a WDT while in STOP mode. A 0 in this bit (cold) indicates that the device will be reset by a POR or WDT while not in STOP.

**Stop-Mode Recovery Register 2 (SMR2).** This register determines the mode of STOP mode recovery for SMR2. (Figure 49)

If SMR2 is used in conjunction with SMR, either of the specified events will cause a Stop-Mode Recovery.

**Note:** Port pins configured as outputs are ignored as a SMR or SMR2 recovery source. For example, if the NAND of P23-P20 is selected as the recovery source and P20 is configured as an output then the remaining SMR pins (P23-P21) form the NAND equation.

COUNTER/TIMER REGISTER DESCRIPTION (Continued)



Note: If used in conjunction with SMR, either of the two specified events will cause a Stop-Mode Recovery.

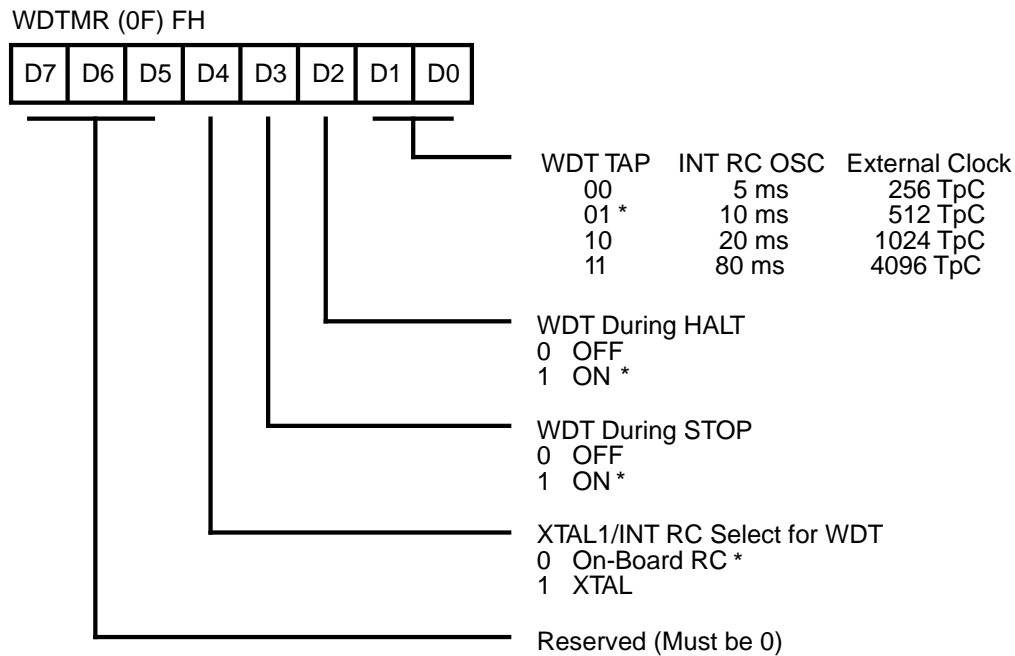
\*Default Setting After Reset

**Figure 42. Stop-Mode Recovery Register 2 ((0F) DH: D2-D4, D6 Write Only)**

**Watch-Dog Timer Mode Register (WDTMR).** The WDT is a retriggerable one-shot timer that resets the Z8 if it reaches its terminal count. The WDT must initially be enabled by executing the WDT instruction and refreshed on subsequent executions of the WDT instruction. The WDT circuit is driven by an on-board RC oscillator or external oscillator from the XTAL1 pin. The WDT instruction affects the Zero (Z), Sign (S), and Overflow (V) flags.

The POR clock source is selected with bit 4 of the WDT register. Bit 0 and 1 control a tap circuit that determines the time-out period. Bit 2 determines whether the WDT is active during HALT and Bit 3 determines WDT activity during STOP. Bits 5 through 7 are reserved (Figure 48).

This register is accessible only during the first 64 processor cycles (128 XTAL clocks) from the execution of the first instruction after Power-On-Reset, Watch-Dog Reset, or a Stop-Mode Recovery (Figure 40). After this point, the register cannot be modified by any means, intentional or otherwise. The WDTMR cannot be read and is located in Bank F of the Expanded Register Group at address location 0FH. It is organized as follows:



\* Default Setting After Reset

**Figure 43. Watch-Dog Timer Mode Register (Write Only)**

**WDT Time Select (D0, D1).** Selects the WDT time period. It is configured as shown in Table 13.

**Table 9. WDT Time Select**

D1	D0	Time-Out of Internal RC OSC	Time-Out of XTAL Clock
0	0	5 ms min	256 TpC
0	1	10 ms mi	512 TpC
1	0	20 ms mi	1024 TpC
1	1	80 ms mi	4096 TpC

**Notes:**

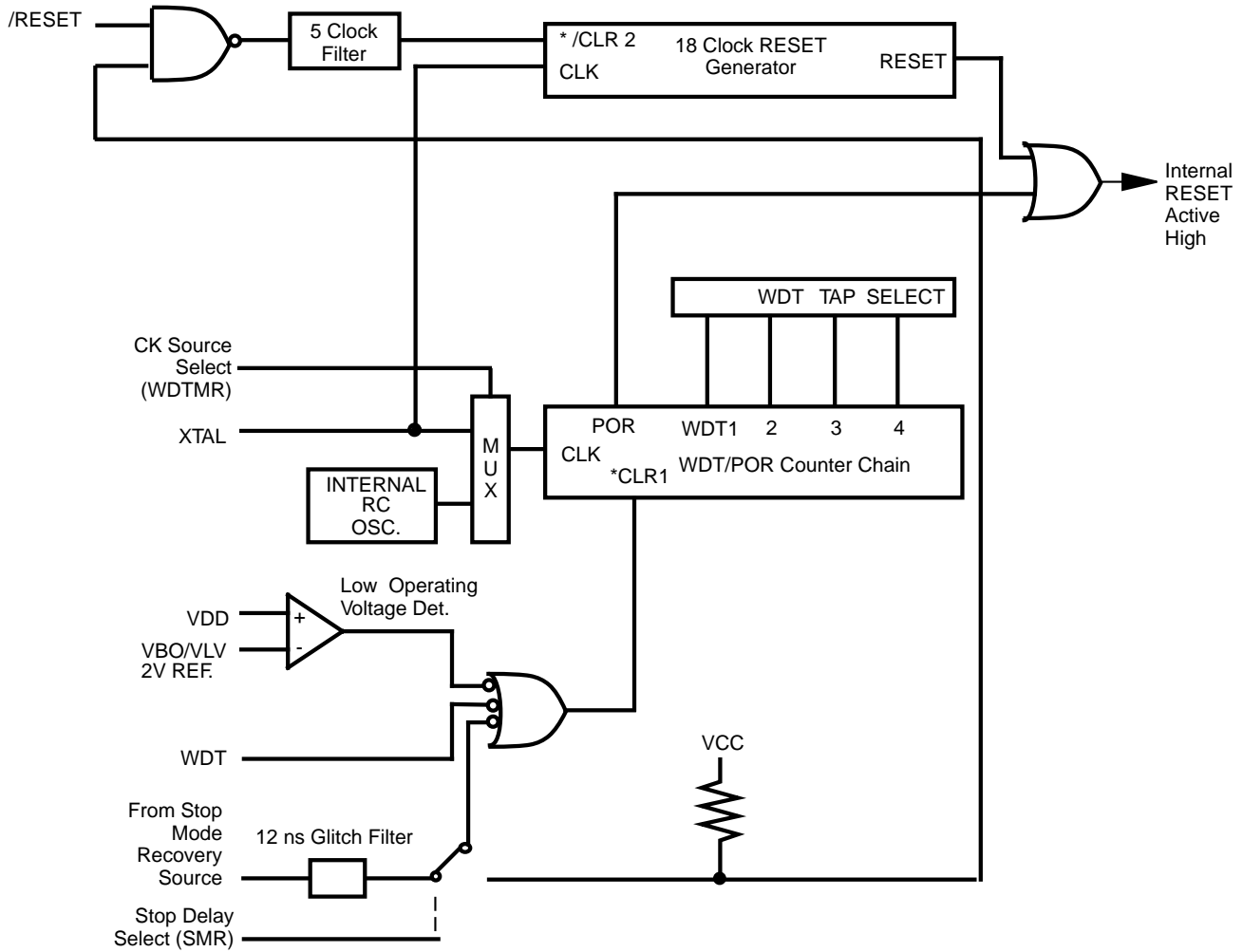
TpC = XTAL clock cycle  
The default on reset is 10 ms

**WDTMR During HALT (D2).** This bit determines whether or not the WDT is active during HALT mode. A 1 indicates active during HALT. The default is 1.

**WDTMR During STOP (D3).** This bit determines whether or not the WDT is active during STOP mode. Since the XTAL clock is stopped during STOP mode, the on-board RC has to be selected as the clock source to the WDT/POR counter. A 1 indicates active during STOP. The default is 1.

**Clock Source for WDT (D4).** This bit determines which oscillator source is used to clock the internal POR and WDT counter chain. If the bit is a 1, the internal RC oscillator is bypassed and the POR and WDT clock source is driven from the external pin, XTAL1. The default configuration of this bit is 0, which selects the RC oscillator.

COUNTER/TIMER REGISTER DESCRIPTION (Continued)



\*  $\overline{\text{CLR1}}$  and  $\overline{\text{CLR2}}$  enable the WDT/POR and 18 Clock Reset timers upon a Low to High input translation.

Figure 44. Resets and WDT

**Low Voltage Protection.** An on-board Voltage Comparator checks that  $V_{CC}$  is at the required level to ensure correct operation of the device. Reset is globally driven if  $V_{CC}$  is below  $V_{LV}$  (Low Voltage). The minimum operating voltage varies with the temperature and operating frequency, while  $V_{LV}$  varies with temperature only.

**Software Selectable Options.** There are four Software Selectable Options to choose from which corresponds to the ROM based parts mask options. Register (F0) EH OTP byte is where these options are controlled; these options are:

Bit Name	Reg(0F)EH
Port 0 Pull-ups (lower nibble)	On/Off
Port 0 Pull-ups (upper nibble)	On/Off
Port 2 Pull-ups	On/Off
Mouse/Normal	M/N

**Note:** The RC oscillator Xtal1/2 option is invoked during OTP programming as a user-selectable item.

The Low Voltage trip voltage ( $V_{LV}$ ) is less than 3.0V under the following conditions:

Maximum ( $V_{LV}$ ) Conditions:

$T_A = 0^\circ\text{C}, +70^\circ\text{C}$  Internal clock frequency equal to or less than 8.0 MHz

**Note:** The internal clock frequency is one-half the external clock frequency.

The device functions normally above 3.0V under all conditions. The minimum functionality point below 3V is to be defined. The  $V_{LV}$  is a function of temperature and process parameters.

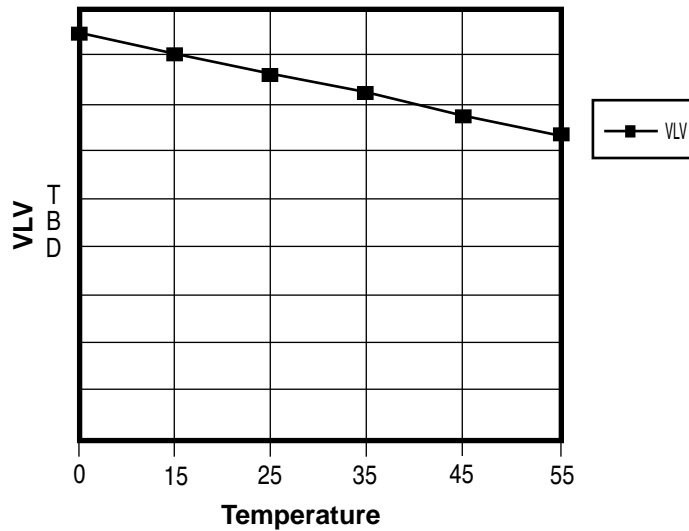


Figure 45. Typical Z86E7X Low Voltage vs Temperature at 8 MHz

## EPROM PROGRAMMING

Table 10. Programming and Testmode

Device Pins										
User/Test Mode	P33	P32	Pref1	P31	P20			Port 1	Test	
Device Pin #	V <sub>PP</sub>	EPM	/ICE	/OE	/PGM	Addr	V <sub>CC</sub>	CNFG	ADDR	
User Modes								DATA	A0-A3	Note
EPROM Read	V <sub>CC</sub>	V <sub>H</sub>	V <sub>IL</sub>	V <sub>IL</sub>	V <sub>IH</sub>	Addr	3.0V	Out	XX	
Program	V <sub>PP</sub>	V <sub>CC</sub>	V <sub>IL</sub>	V <sub>IH</sub>	V <sub>IL</sub>	Addr	6.0V	In	XX	
Program Verify	V <sub>PP</sub>	V <sub>CC</sub>	V <sub>IL</sub>	V <sub>IL</sub>	V <sub>IH</sub>	Addr	6.0V	Out	XX	
RC Option	V <sub>PP</sub>	V <sub>CC</sub>	V <sub>H</sub>	V <sub>IH</sub>	V <sub>IL</sub>	XX	6.0V	XX	XX	
Margin Read	V <sub>VA</sub>	V <sub>H</sub>	V <sub>IL</sub>	V <sub>H</sub>	V <sub>IH</sub>	Addr	6.0V	Out	00	1
Shadow Row Rd	V <sub>CC</sub>	V <sub>H</sub>	V <sub>IL</sub>	V <sub>IL</sub>	V <sub>IH</sub>	COL	3.0V	Out	01	1
Shadow Row Prg	V <sub>PP</sub>	V <sub>H</sub>	V <sub>IL</sub>	V <sub>IH</sub>	V <sub>IL</sub>	COL	6.0V	In	01	1
Shadow Row Ver	V <sub>PP</sub>	V <sub>H</sub>	V <sub>IL</sub>	V <sub>IL</sub>	V <sub>IH</sub>	COL	6.0V	Out	01	1
Shadow Col Rd	V <sub>CC</sub>	V <sub>H</sub>	V <sub>IL</sub>	V <sub>IL</sub>	V <sub>IH</sub>	ROW	3.0V	Out	02	1
Shadow Col Prg	V <sub>PP</sub>	V <sub>H</sub>	V <sub>IL</sub>	V <sub>IH</sub>	V <sub>IL</sub>	ROW	6.0V	In	03	1
Shadow Col Ver	V <sub>PP</sub>	V <sub>H</sub>	V <sub>IL</sub>	V <sub>IL</sub>	V <sub>IH</sub>	ROW	6.0V	Out	02	1
Page Prg 2 Byte	V <sub>PP</sub>	V <sub>H</sub>	V <sub>IL</sub>	V <sub>IH</sub>	V <sub>IL</sub>	TBD	6.0V	In	04	1
Page Prg 4 Byte	V <sub>PP</sub>	V <sub>H</sub>	V <sub>IL</sub>	V <sub>IH</sub>	V <sub>IL</sub>	TBD	6.0V	In	05	1
Page Prg 8 Byte	V <sub>PP</sub>	V <sub>H</sub>	V <sub>IL</sub>	V <sub>IH</sub>	V <sub>IL</sub>	TBD	6.0V	In	06	1
Page Prg 16 Byte	V <sub>PP</sub>	V <sub>H</sub>	V <sub>IL</sub>	V <sub>IH</sub>	V <sub>IL</sub>	TBD	6.0V	In	07	1

**Notes:**

- All test modes are entered by first setting up the corresponding test address and then latching the address by bringing the /OE to V<sub>H</sub> and then to V<sub>IL</sub>, except for the margin read which requires /OE to be kept at V<sub>H</sub>.

V<sub>VA</sub> = Variable from V<sub>CC</sub> to V<sub>PP</sub>

V<sub>PP</sub> = 12.5V ± 0.5V

V<sub>H</sub> = 12.5V ± 0.5V

V<sub>IH</sub> = 3V

V<sub>IL</sub> = 0V

XX = Irrelevant

I<sub>PP</sub> during programming = 40 mA maximum

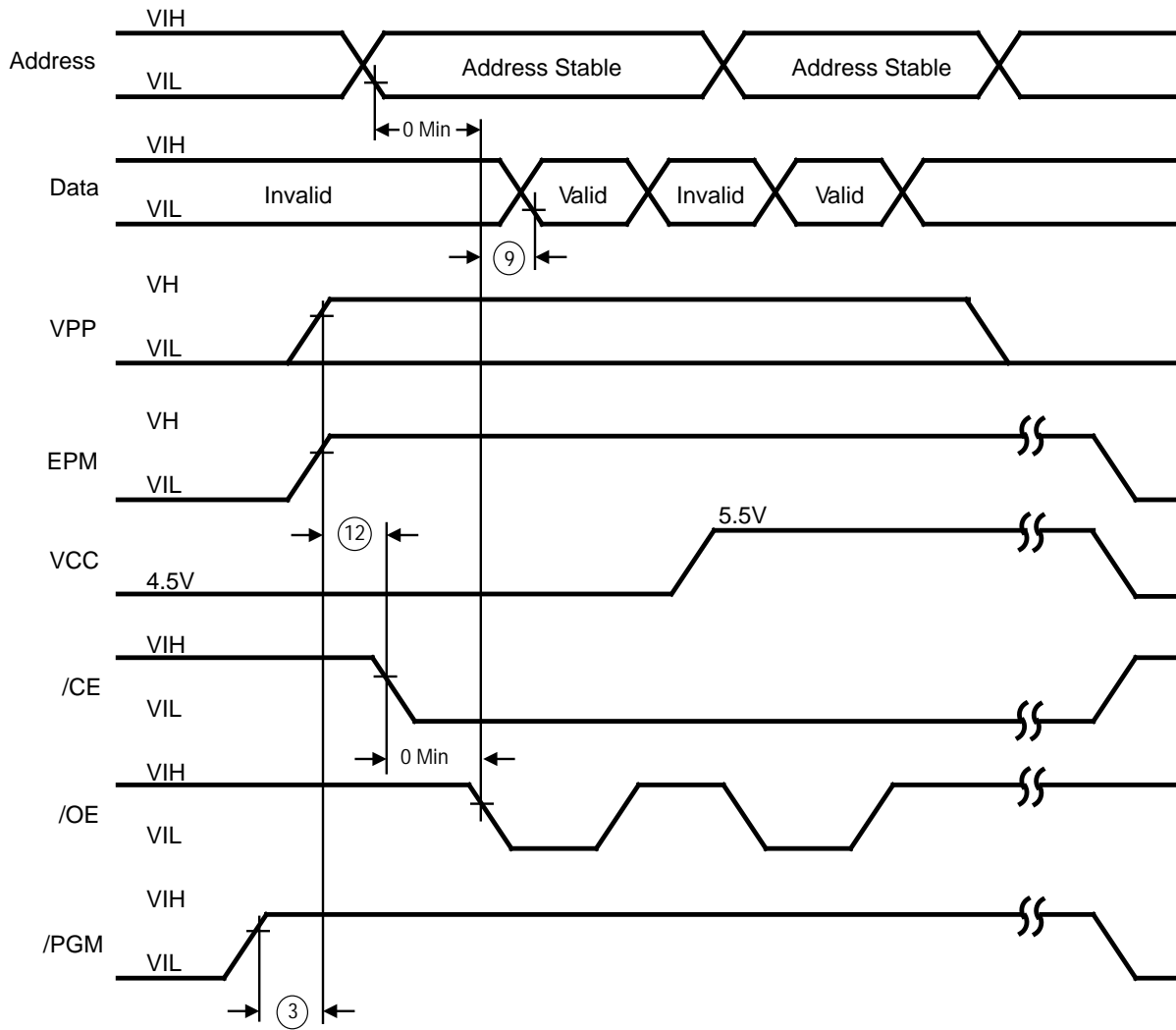
I<sub>CC</sub> during programming, verify, or read = 40 mA maximum.



**Table 11. Timing of Programming Waveform**

<b>Parameters</b>	<b>Name</b>	<b>Min</b>	<b>Max</b>	<b>Units</b>
1	Address Setup Time	2		μs
2	Data Setup Time	2		μs
3	V <sub>PP</sub> Setup Time	2		μs
4	V <sub>CC</sub> Setup Time	2		μs
5	Chip Enable Setup Time	2		μs
6	Program Pulse Width	0.95		μs
7	Data Hold Time	2		μs
8	/OE Setup Time	2		μs
9	Data Access Time		200	ns
10	Data Output Float Time		100	ns
11	Overprogram Pulse Width	2.85		ms
12	EPM Setup Time	2		μs
13	/PGM Setup Time	2		μs
14	Address to /OE Setup Time	2		μs
15	Option Program Pulse Width	78		ms

**EPROM PROGRAMMING** (Continued)



**Figure 46. EPROM Read**

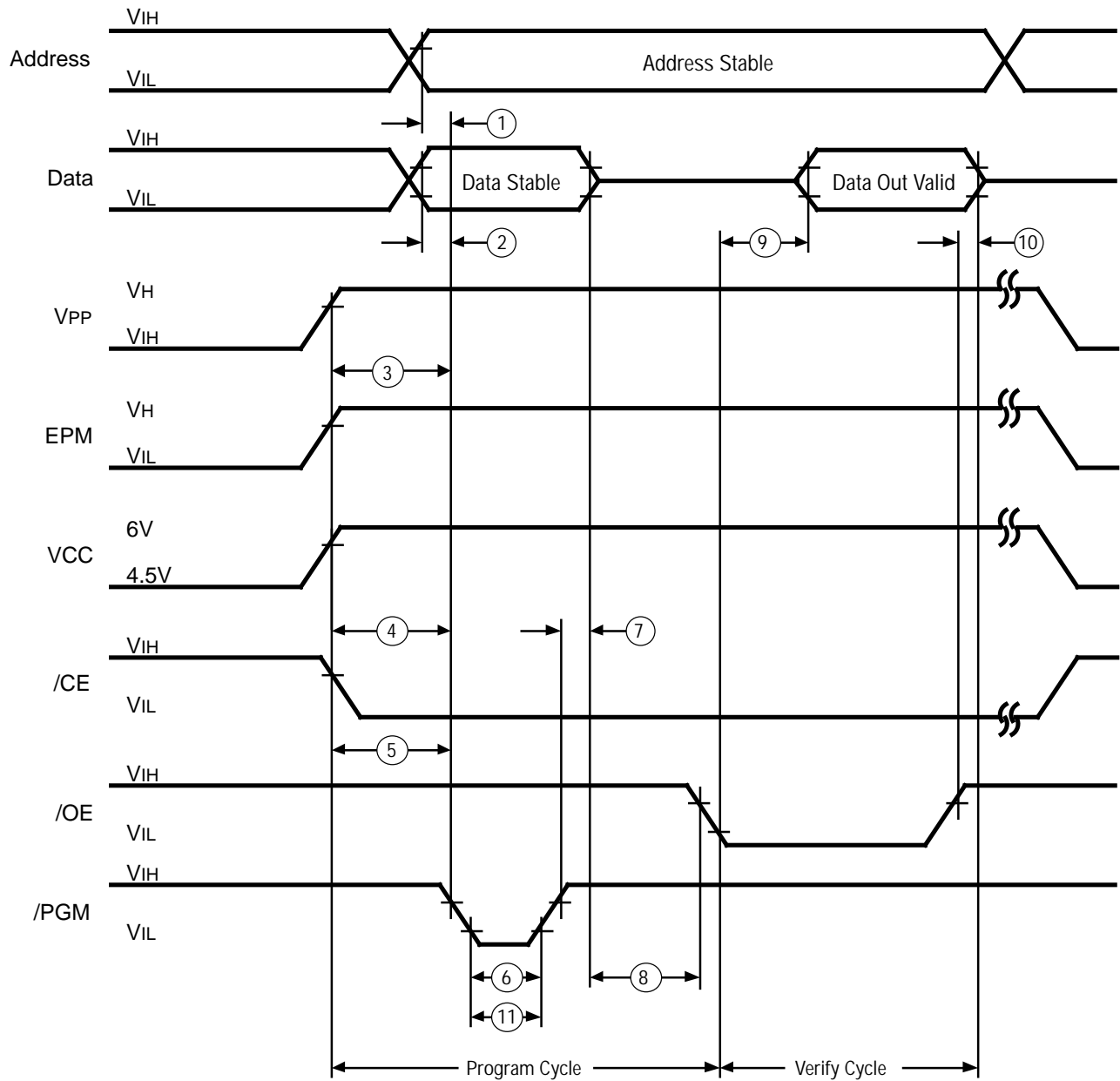
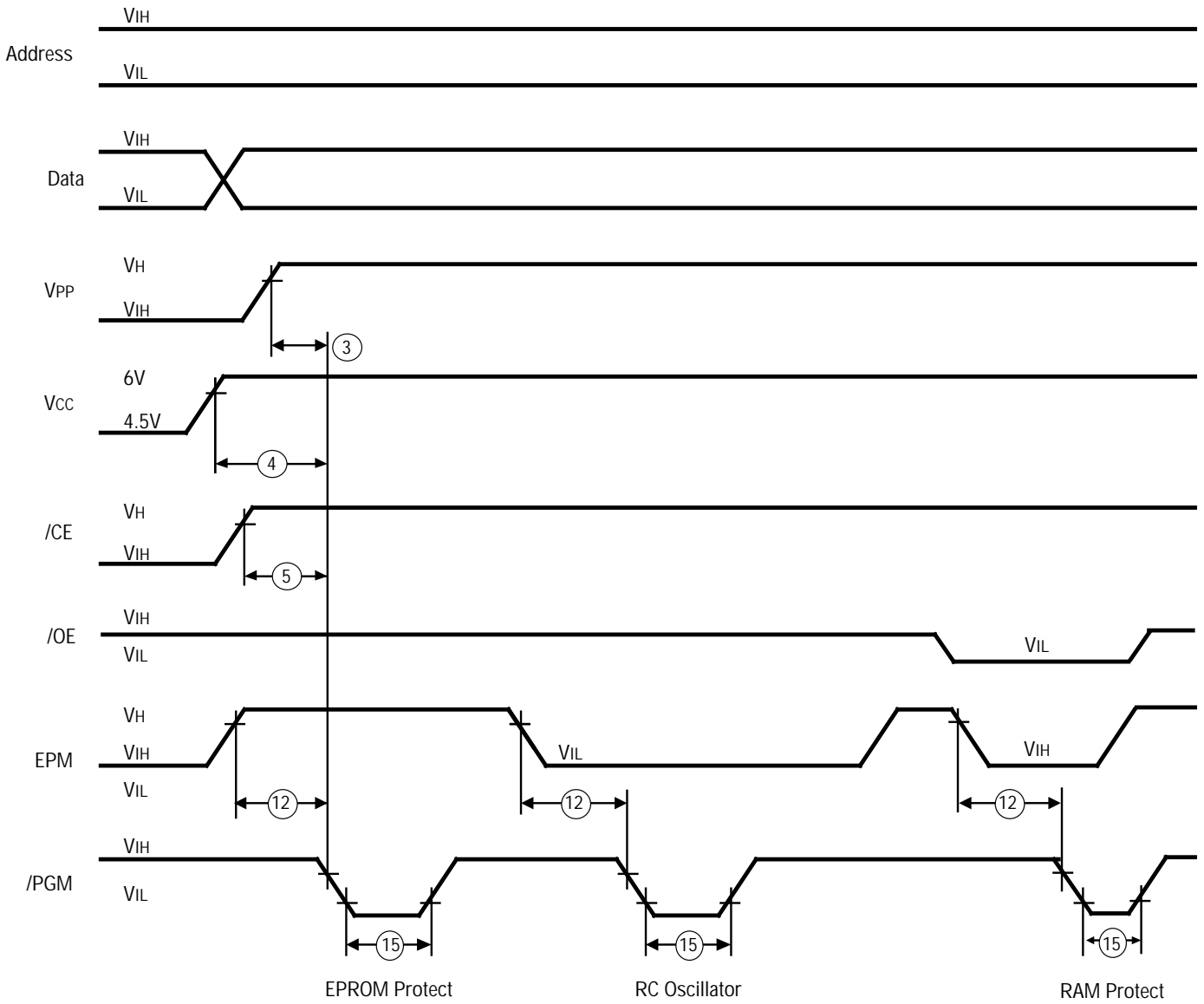


Figure 47. EPROM Program and Verify

**EPROM PROGRAMMING (Continued)**



**Figure 48. Programming EPROM, RAM Protect and 16K Size Selection**

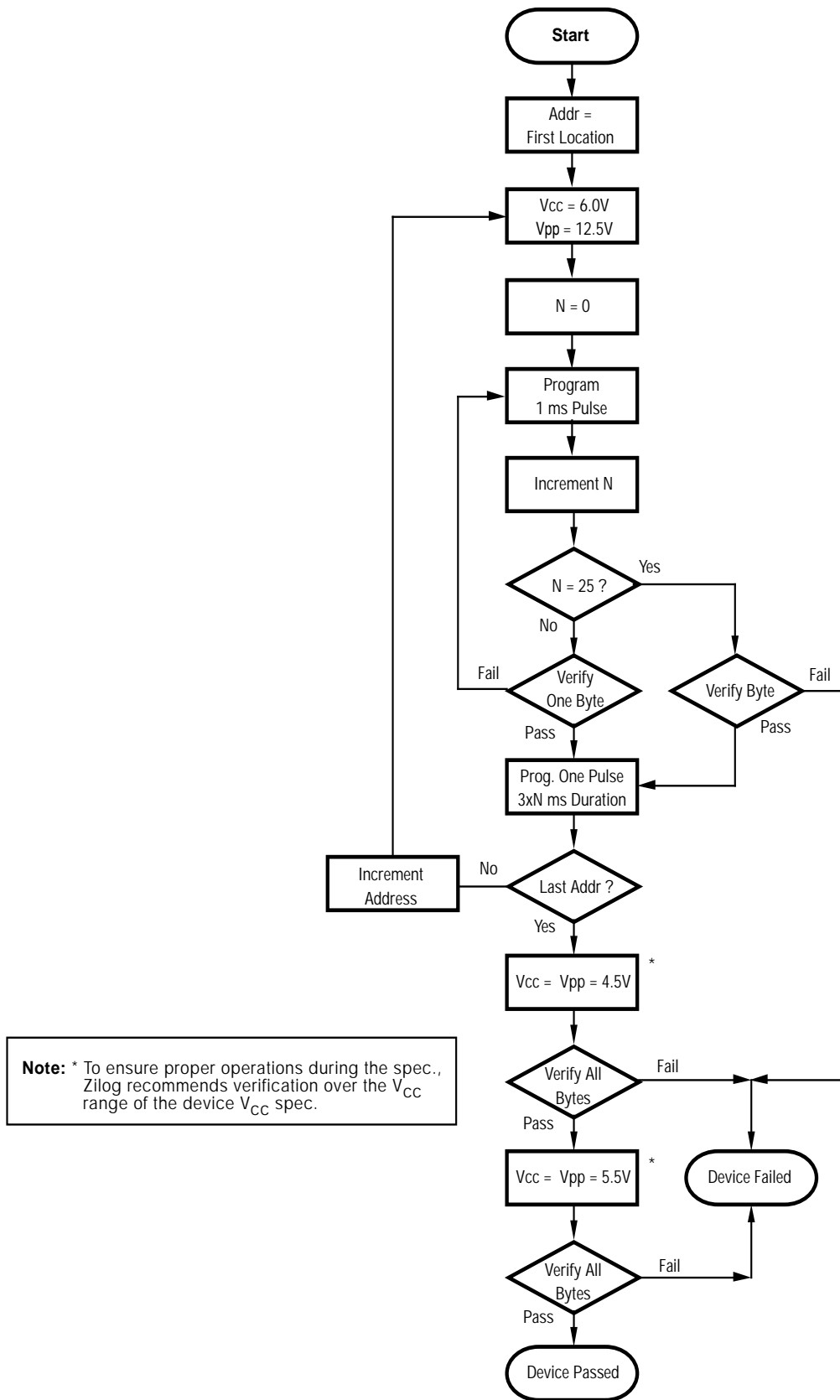
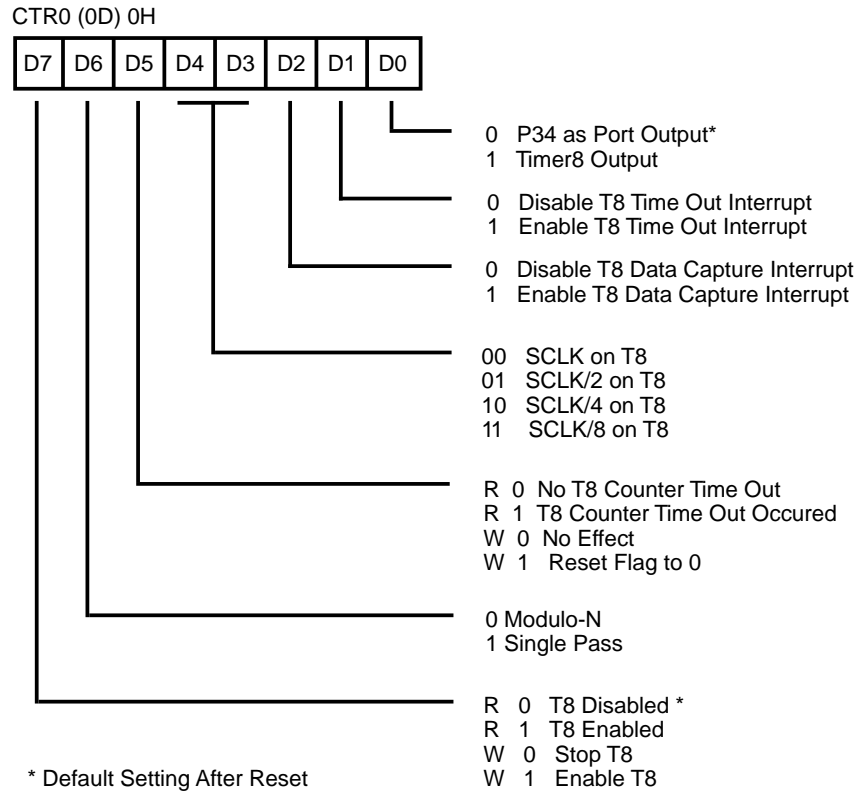


Figure 49. Programming Flowchart

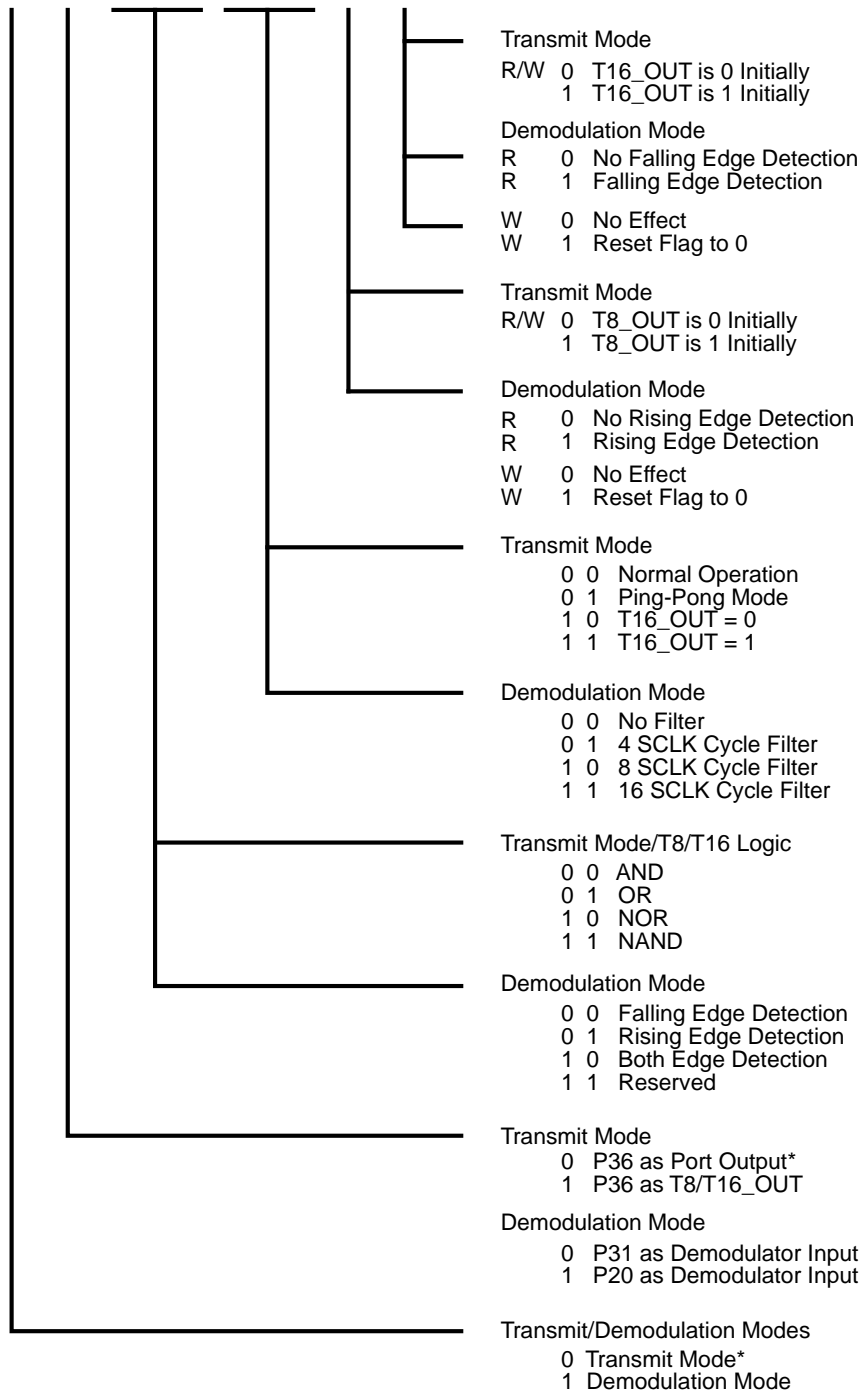
**EXPANDED REGISTER FILE CONTROL REGISTERS (0D)**



**Figure 50. TC8 Control Register  
 ((0D) 0H: Read/Write Except Where Noted)**

CTR1 (0D) 1H

D7	D6	D5	D4	D3	D2	D1	D0
----	----	----	----	----	----	----	----



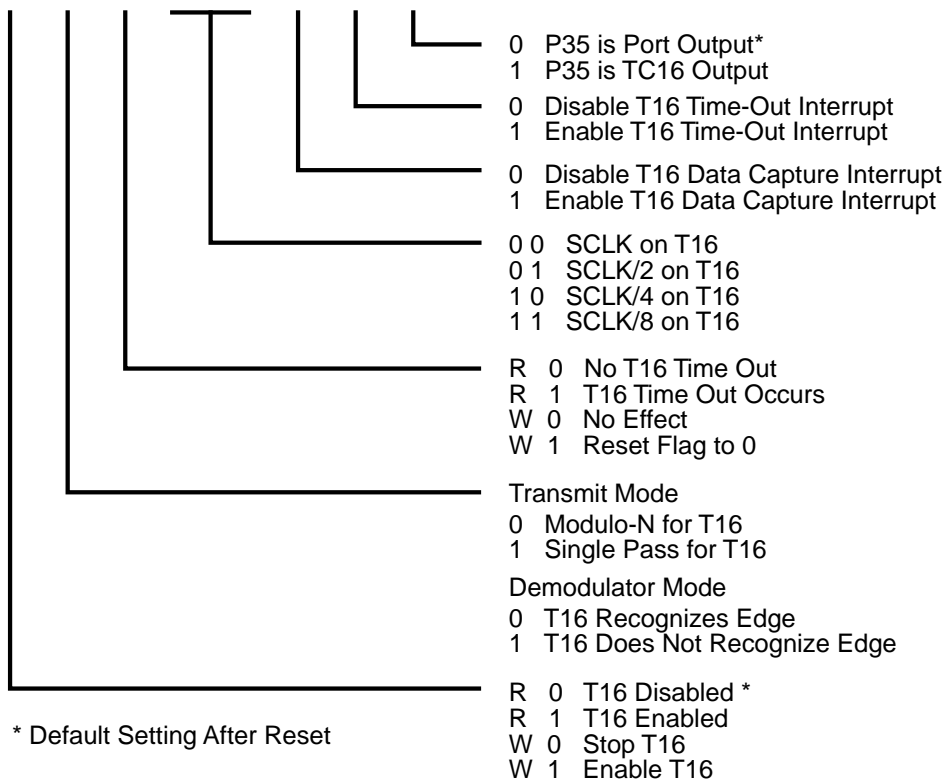
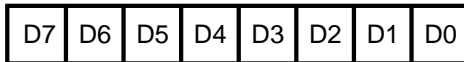
**Note:** Care must be taken in differentiating Transmit Mode from Demodulation Mode. Depending on which of these two modes is operating, the CTR1 bit will have different functions.

**\*Note:** Changing from one mode to another cannot be done without disabling the counter/timers.

**Figure 51. T8 and T16 Common Control Functions ((0D) 1H: Read/Write)**

**EXPANDED REGISTER FILE CONTROL REGISTERS (0D) (Continued)**

CTR2 (0D) 02H

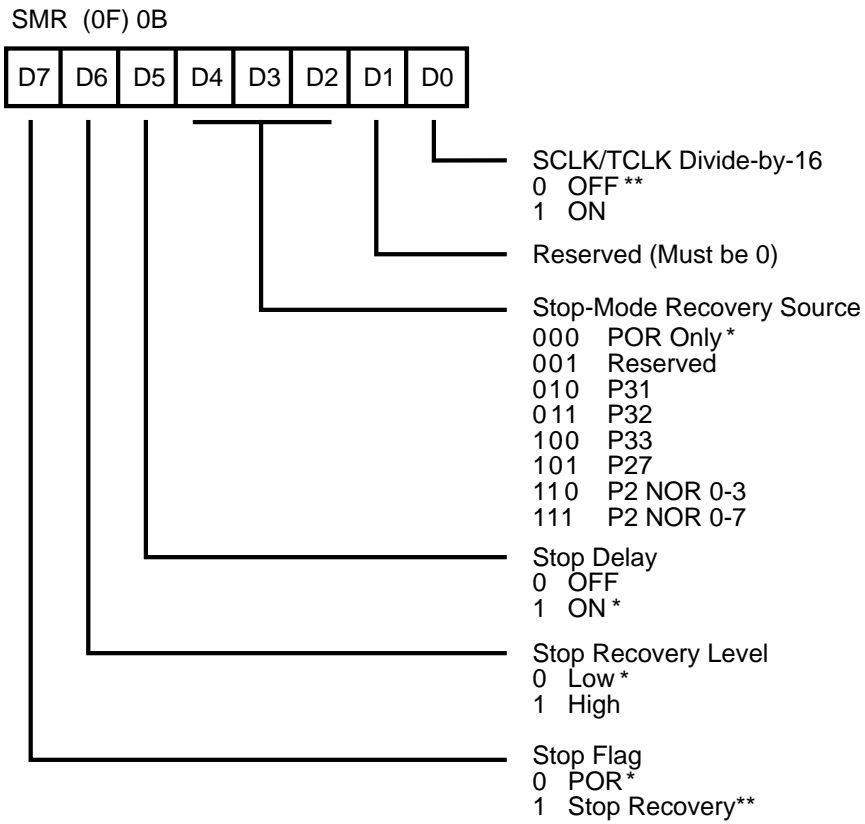


\* Default Setting After Reset

**Figure 52. T16 Control Register  
 ((0D) 2H: Read/Write Except Where Noted)**



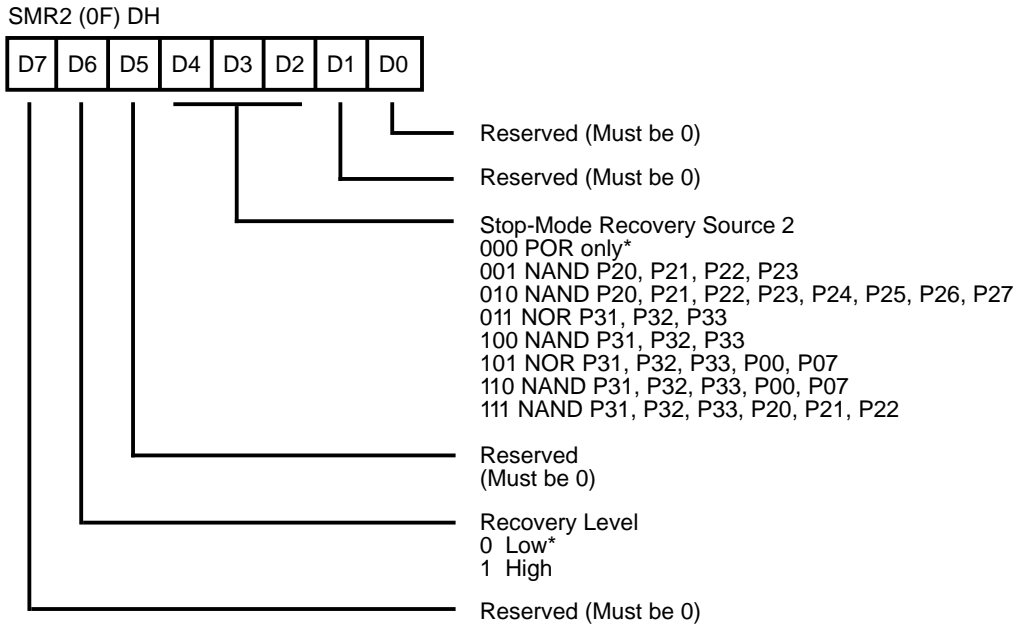
EXPANDED REGISTER FILE CONTROL REGISTERS (0F)



\* Default Setting After Reset

\*\* Default Setting After Reset and Stop-Mode Recovery

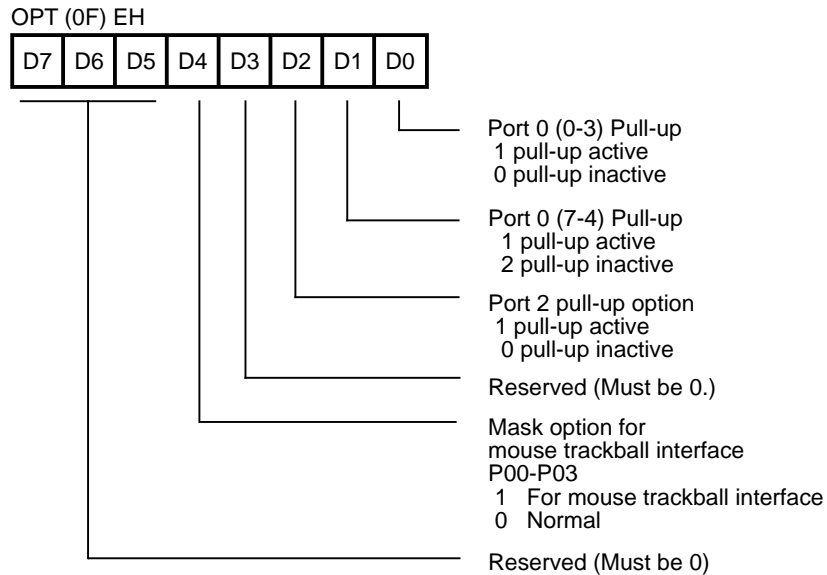
**Figure 53. Stop-Mode Recovery Register  
(F) 0BH: D6-D0 = Write Only, D7 = Read Only)**



Note: If used in conjunction with SMR, either of the two specified events will cause a Stop-Mode Recovery.

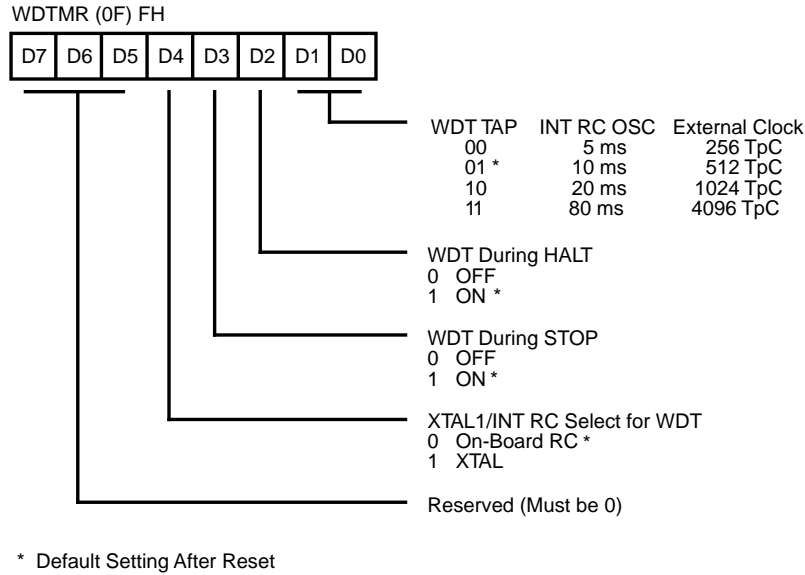
\*Default Setting After Reset

**Figure 54. Stop-Mode Recovery Register 2 ((0F) DH: D2-D4, D6 Write Only)**

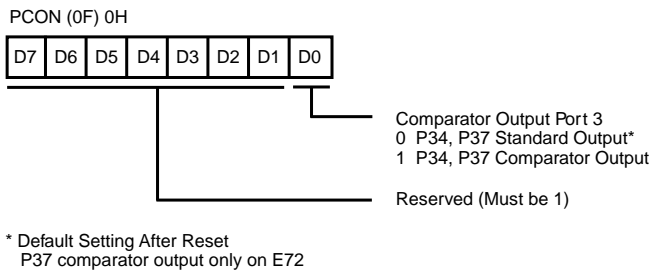


**Figure 55. Option Bit Register**

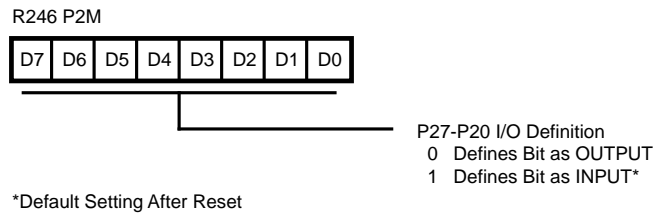
EXPANDED REGISTER FILE CONTROL REGISTERS (0F) (Continued)



**Figure 56. Watch-Dog Timer Mode Register ((F) 0FH: Write Only)**

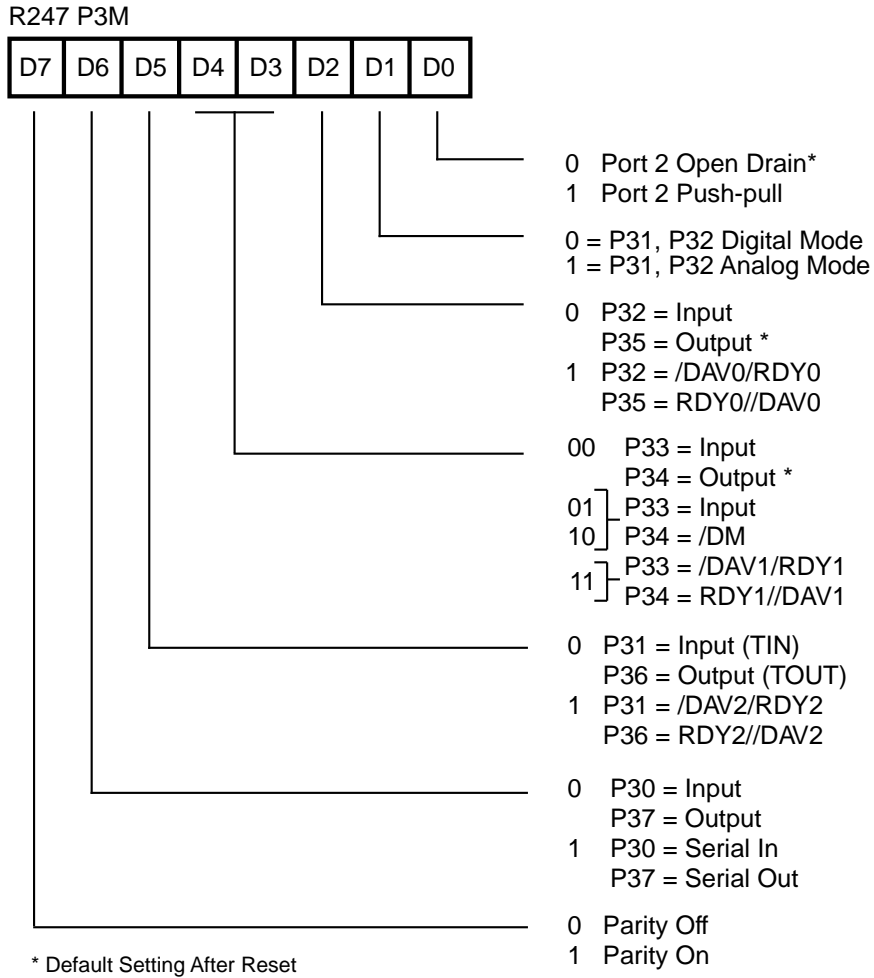


**Figure 57. Port Configuration Register (PCON) ((0F) 0H: Write Only)**



**Figure 58. Port 2 Mode Register (F6H: Write Only)**

Z8<sup>®</sup> STANDARD CONTROL REGISTER DIAGRAMS



**Figure 59. Port 3 Mode Register  
(F7H: Write Only)**

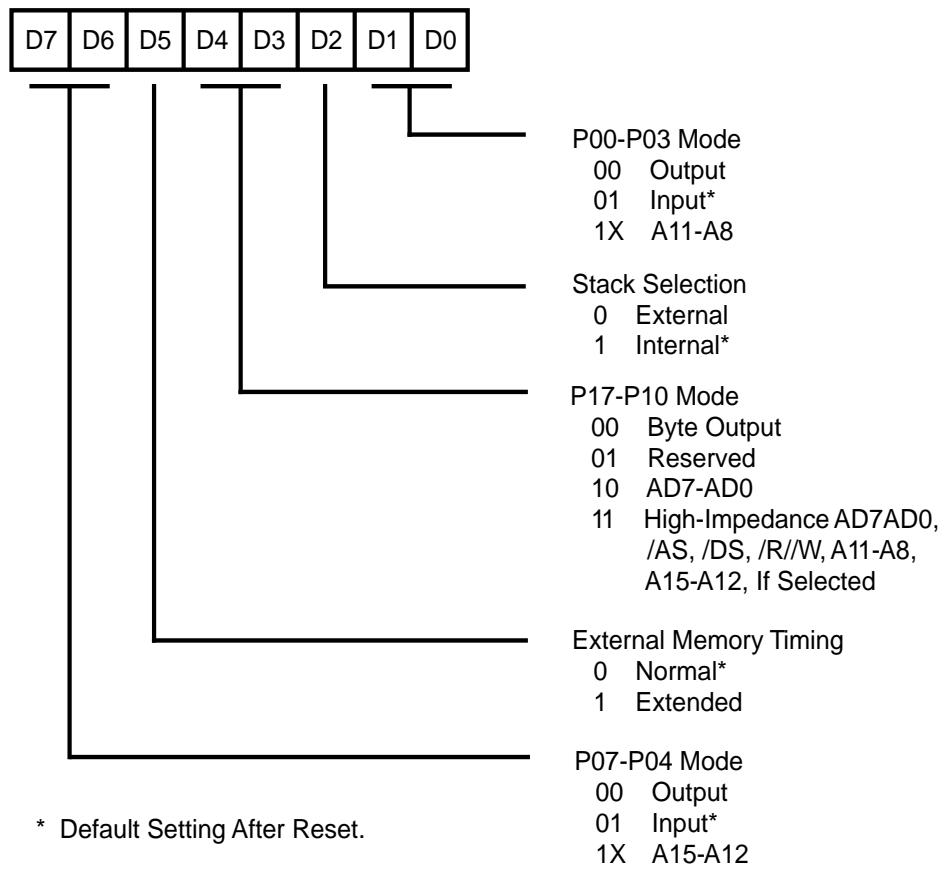
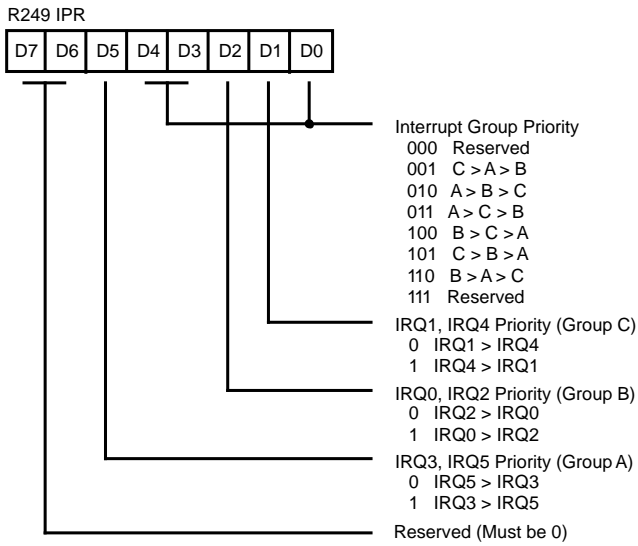
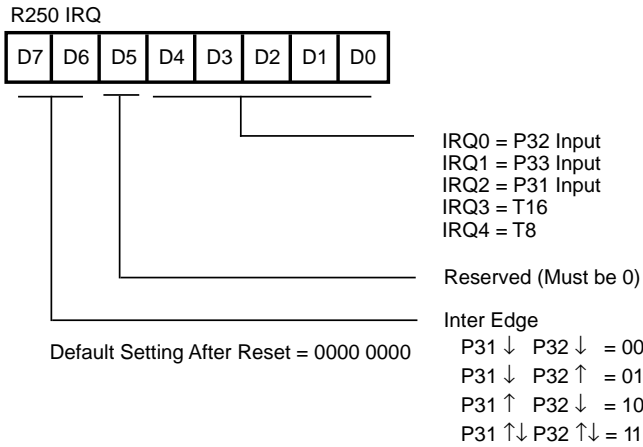


Figure 60. Port 0 and 1 Mode Register (F8H: Write Only)

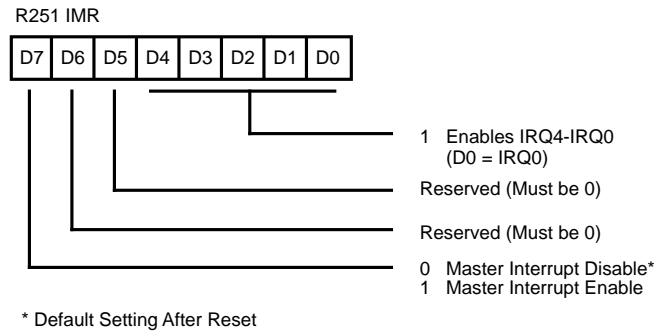
Z8® STANDARD CONTROL REGISTER DIAGRAMS (Continued)



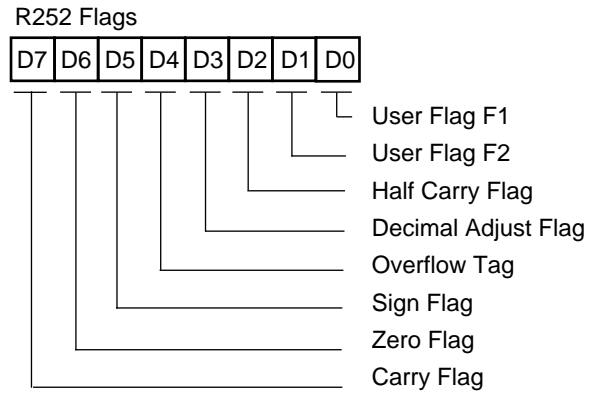
**Figure 61. Interrupt Priority Registers  
(0) F9H: Write Only**



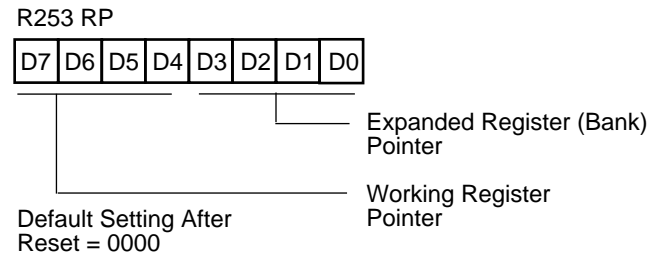
**Figure 62. Interrupt Request Register  
(0) FAH: Read/Write**



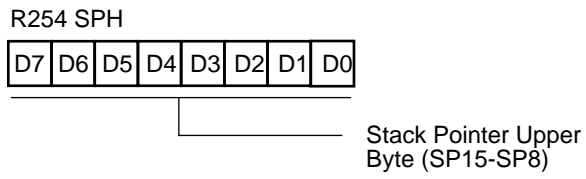
**Figure 63. Interrupt Mask Register  
(0) FBH: Read/Write**



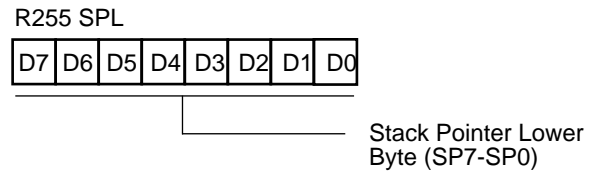
**Figure 64. Flag Register  
(0) FCH: Read/Write**



**Figure 65. Register Pointer  
(0) FDH: Read/Write**



**Figure 66. Stack Pointer High**  
**((0) FEH: Read/Write)**



**Figure 67. Stack Pointer Low**  
**((0) FFH: Read/Write)**

PACKAGE INFORMATION

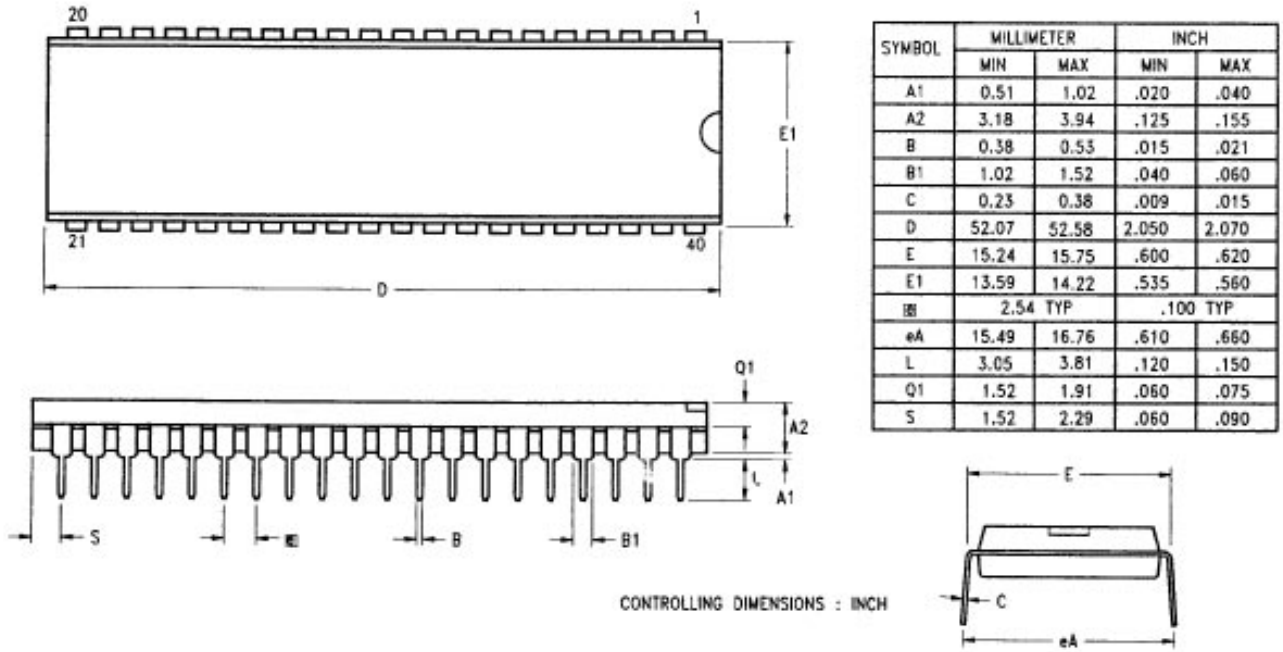


Figure 68. 40-Pin DIP Package Diagram



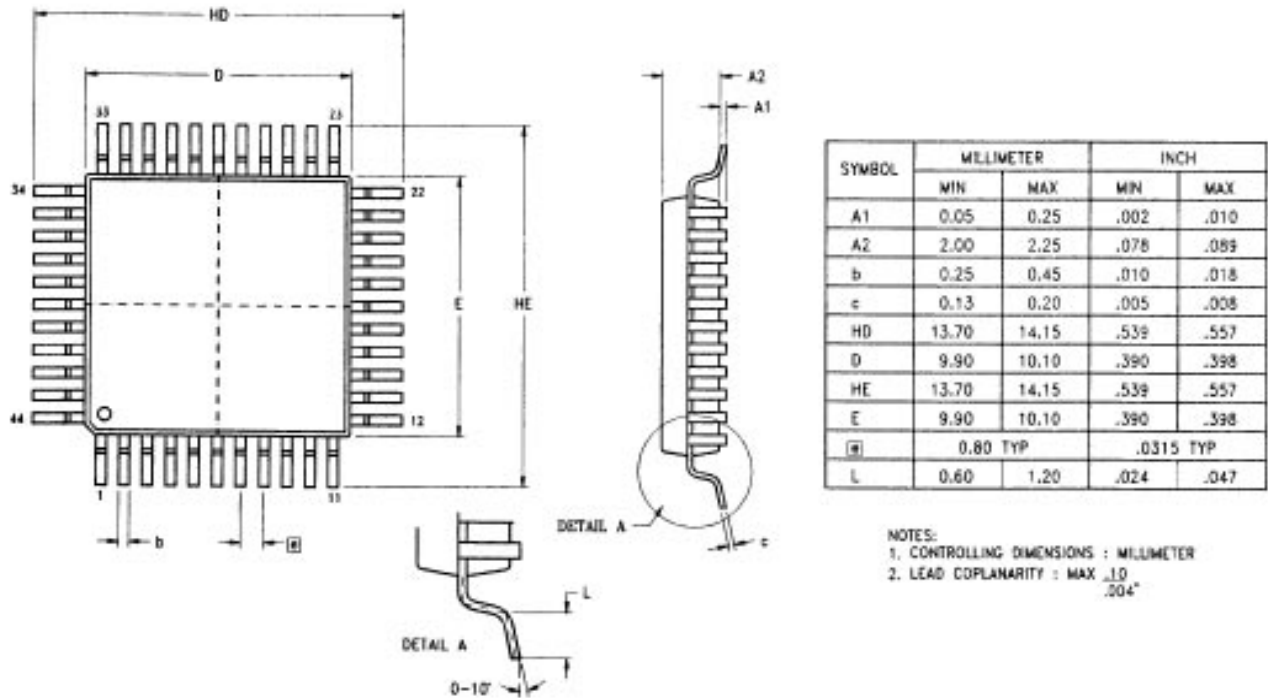


Figure 69. 44-Pin QFP Package Diagram

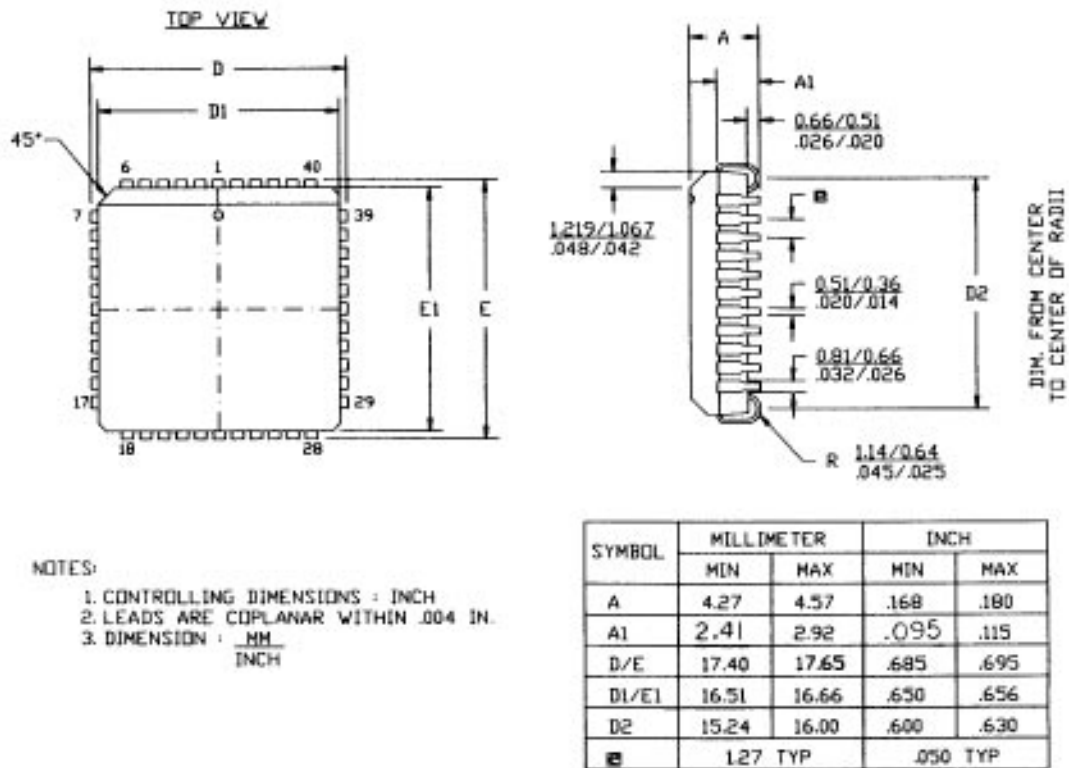


Figure 70. 44-Pin PLCC Package Diagram

## ORDERING INFORMATION

Z86E72/E73 16 MHz		
40-Pin DIP	44-Pin PLCC	44-Pin QFP
Z86E7216PSC	Z86E7216VSC	Z86E7216FSC
Z86E7316PSC	Z86E7316VSC	Z86E7316FSC

For fast results, contact your local Zilog sales office for assistance in ordering the part desired.

### Package

P = Plastic DIP  
F = Plastic Quad Flat Pack  
V = Plastic Chip Carrier

### Temperature

S = 0°C to +70°C

### Speed

16 = 16 MHz

### Environmental

C = Plastic Standard

### Example:

**Z 86E73 16 P S C** is an Z86E73, 16 MHz, DIP, 0°C to +70°C, Plastic Standard Flow

