

# Data Sheet



## THE SCA61T INCLINOMETER SERIES

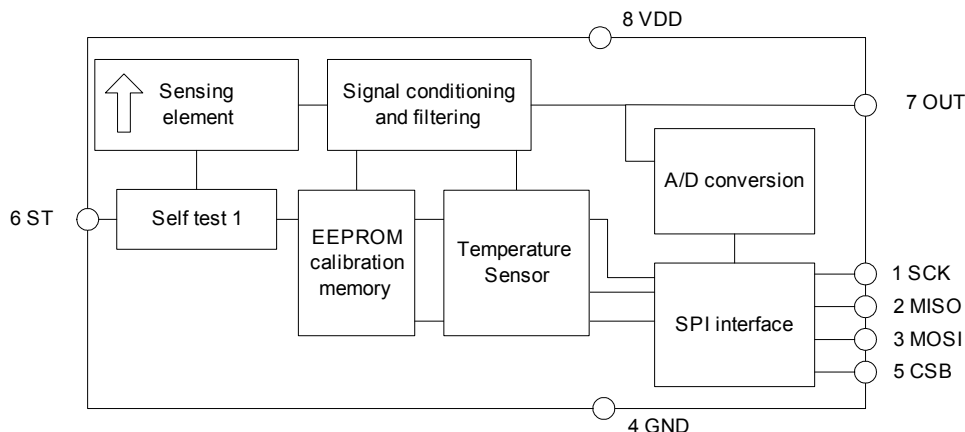
The SCA61T Series is a 3D-MEMS-based single axis inclinometer family that provides instrumentation grade performance for leveling applications. Low temperature dependency, high resolution and low noise together with robust sensing element design make the SCA61T ideal choice for leveling instruments. The VTI inclinometers are insensitive to vibration, due to their over damped sensing elements and can withstand mechanical shocks of 20000 g.

### Features

- Measuring ranges  $\pm 30^\circ$  SCA61T-FAHH1G and  $\pm 90^\circ$  SCA61T-FA1H1G
- 0.0025° resolution (10 Hz BW, analog output)
- Sensing element controlled over damped frequency response (-3dB 18Hz)
- Robust design, high shock durability (20000g)
- Excellent stability over temperature and time
- Single +5 V supply
- Ratiometric analog voltage outputs
- Digital SPI inclination and temperature output
- Comprehensive failure detection features
  - True self test by deflecting the sensing elements' proof mass by electrostatic force.
  - Continuous sensing element interconnection failure check.
  - Continuous memory parity check.
- RoHS compliant
- Compatible with Pb-free reflow solder process

### Applications

- Platform leveling and stabilization
- Leveling instruments
- Acceleration and motion measurement



**Figure 1.** Functional block diagram

# TABLE OF CONTENTS

**The SCA61T Inclinometer Series.....1**

    Features.....1

    Applications .....1

**Table of Contents .....2**

**1 Electrical Specifications .....3**

    1.1 Absolute Maximum Ratings.....3

    1.2 Performance Characteristics .....3

    1.3 Electrical Characteristics .....4

    1.4 SPI Interface DC Characteristics .....4

    1.5 SPI Interface AC Characteristics .....4

    1.6 SPI Interface Timing Specifications .....5

    1.7 Electrical Connection .....6

    1.8 Typical Performance Characteristics.....6

    1.9 Additional External Compensation .....7

**2 Functional Description .....9**

    2.1 Measuring Directions .....9

    2.2 Voltage to Angle Conversion.....9

    2.3 Ratiometric Output .....9

    2.4 SPI Serial Interface .....10

    2.5 Digital Output to Angle Conversion .....12

    2.6 Self Test and Failure Detection Modes .....13

    2.7 Temperature Measurement.....14

**3 Application Information .....15**

    3.1 Recommended Circuit Diagrams and Printed Circuit Board Layouts .....15

    3.2 Recommended Printed Circuit Board Footprint .....16

**4 Mechanical Specifications and Reflow Soldering .....16**

    4.1 Mechanical Specifications (Reference only) .....16

    4.2 Reflow Soldering.....17

**5 Document Change Control .....18**

**6 Contact Information .....18**

## 1 Electrical Specifications

The SCA61T product family comprises two versions, the SCA61T-FAHH1G and the SCA61T-FA1H1G, that differ in measurement range. The product version specific performance specifications are listed in the following table below. All other specifications are common to both versions. Vdd=5.00V and ambient temperature unless otherwise specified.

### 1.1 Absolute Maximum Ratings

Supply voltage (VDD)	-0.3 V to +5.5V
Voltage at input / output pins	-0.3V to (VDD + 0.3V)
Storage temperature	-55°C to +125°C
Operating temperature	-40°C to +125°C
Mechanical shock	Drop from 1 meter on a concrete surface (20000g). Powered or non-powered

### 1.2 Performance Characteristics

Parameter	Condition	SCA61T-FAHH1G	SCA61T-FA1H1G	Units
Measuring range	Nominal	±30	±90	°
		±0.5	±1.0	g
Frequency response	-3dB LP <sup>(1)</sup>	8-28	8-28	Hz
Offset (Output at 0g)	Ratiometric output	Vdd/2	Vdd/2	V
Offset calibration error		±0.11	±0.23	°
Offset Digital Output		1024	1024	LSB
Sensitivity		4	2	V/g
	between 0...1° <sup>(2)</sup>	70	35	mV/°
Sensitivity calibration error		±0.5	±0.5	%
Sensitivity Digital Output		1638	819	LSB / g
Offset temperature dependency	-25...85°C (typical)	±0.008	±0.008	°/°C
	-40...125°C (max)	±0.86	±0.86	°
Sensitivity temperature dependency	-25...85°C (typical)	±0.014	±0.014	%/°C
	-40...125°C (max)	-2.5...+1	-2.5...+1	%
Typical non-linearity	Measuring range	±0.11	±0.57	°
Digital output resolution		11	11	Bits
	between 0...1° <sup>(2)</sup>	0.035	0.07	° / LSB
Output noise density	From DC...100Hz	0.0008	0.0008	° / √Hz
Analog output resolution	Bandwidth 10 Hz <sup>(3)</sup>	0.0025	0.0025	°
Ratiometric error	Vdd = 4.75...5.25V	±1	±1	%
Cross-axis sensitivity	Max.	4	4	%
Long term Stability <sup>(4)</sup>		<0.014	<0.014	°

Note 1. The frequency response is determined by the sensing element's internal gas damping.

Note 2. The angle output has SIN curve relationship to voltage output refer to paragraph 2.2

Note 3. Resolution = Noise density \* √(bandwidth)

Note 4. Power continuously connected (@ 23°C).

### 1.3 Electrical Characteristics

Parameter	Condition	Min.	Typ	Max.	Units
Supply voltage Vdd		4.75	5.0	5.25	V
Current consumption	Vdd = 5 V; No load		2.5	4	mA
Operating temperature		-40		+125	°C
Analog resistive output load	Vout to Vdd or GND	10			kOhm
Analog capacitive output load	Vout to Vdd or GND			20	nF
Start-up delay	Reset and parity check			10	ms

### 1.4 SPI Interface DC Characteristics

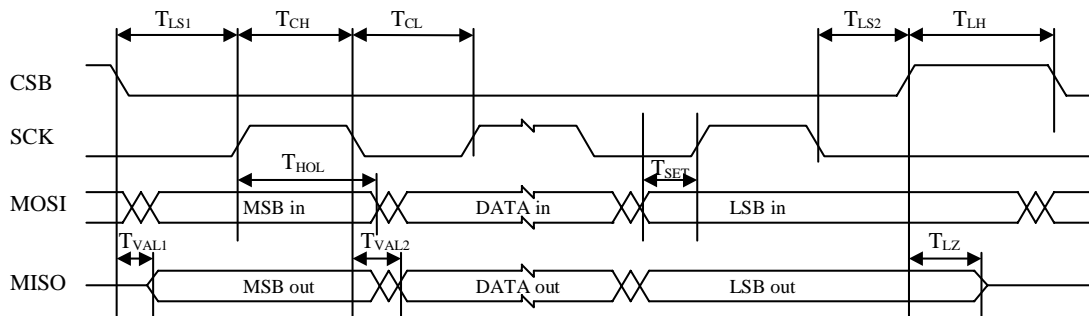
Parameter	Conditions	Symbol	Min	Typ	Max	Unit
1.4.1.1.1 Input terminal CSB						
Pull up current	$V_{IN} = 0\text{ V}$	$I_{PU}$	13	22	35	$\mu\text{A}$
Input high voltage		$V_{IH}$	4		Vdd+0.3	V
Input low voltage		$V_{IL}$	-0.3		1	V
Hysteresis		$V_{HYST}$		0.23*Vdd		V
Input capacitance		$C_{IN}$		2		pF
1.4.1.1.2 Input terminal MOSI, SCK						
Pull down current	$V_{IN} = 5\text{ V}$	$I_{PD}$	9	17	29	$\mu\text{A}$
Input high voltage		$V_{IH}$	4		Vdd+0.3	V
Input low voltage		$V_{IL}$	-0.3		1	V
Hysteresis		$V_{HYST}$		0.23*Vdd		V
Input capacitance		$C_{IN}$		2		pF
1.4.1.1.3 Output terminal MISO						
Output high voltage	$I > -1\text{ mA}$	$V_{OH}$	Vdd-0.5			V
Output low voltage	$I < 1\text{ mA}$	$V_{OL}$			0.5	V
Tristate leakage	$0 < V_{MISO} < V_{dd}$	$I_{LEAK}$		5	100	pA

### 1.5 SPI Interface AC Characteristics

Parameter	Condition	Min.	Typ.	Max.	Units
Output load	@500kHz			1	nF
SPI clock frequency				500	kHz
Internal A/D conversion time			150		$\mu\text{s}$
Data transfer time	@500kHz		38		$\mu\text{s}$

## 1.6 SPI Interface Timing Specifications

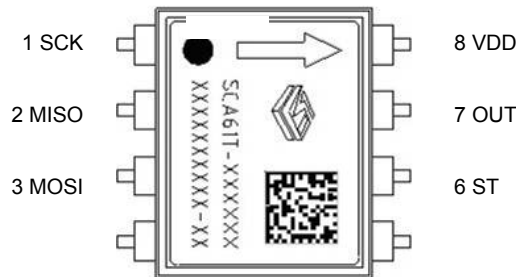
Parameter	Conditions	Symbol	Min.	Typ.	Max.	Unit
<b>Terminal CSB, SCK</b>						
Time from CSB (10%) to SCK (90%)		$T_{LS1}$	120			ns
Time from SCK (10%) to CSB (90%)		$T_{LS2}$	120			ns
<b>Terminal SCK</b>						
SCK low time	Load capacitance at MISO < 2 nF	$T_{CL}$	1			$\mu$ s
SCK high time	Load capacitance at MISO < 2 nF	$T_{CH}$	1			$\mu$ s
<b>Terminal MOSI, SCK</b>						
Time from changing MOSI (10%, 90%) to SCK (90%). Data setup time		$T_{SET}$	30			ns
Time from SCK (90%) to changing MOSI (10%,90%). Data hold time		$T_{HOL}$	30			ns
<b>Terminal MISO, CSB</b>						
Time from CSB (10%) to stable MISO (10%, 90%).	Load capacitance at MISO < 15 pF	$T_{VAL1}$	10		100	ns
Time from CSB (90%) to high impedance state of MISO.	Load capacitance at MISO < 15 pF	$T_{LZ}$	10		100	ns
<b>Terminal MISO, SCK</b>						
Time from SCK (10%) to stable MISO (10%, 90%).	Load capacitance at MISO < 15 pF	$T_{VAL2}$			100	ns
<b>Terminal CSB</b>						
Time between SPI cycles, CSB at high level (90%)		$T_{LH}$	15			$\mu$ s
When using SPI commands RDAX, RDAY, RWTR: Time between SPI cycles, CSB at high level (90%)		$TLH$	150			$\mu$ s



**Figure 2.** Timing diagram for SPI communication

### 1.7 Electrical Connection

If the SPI interface is not used SCK (pin1), MISO (pin3), MOSI (pin4) and CSB (pin7) must be left floating. Self-test can be activated applying logic “1” (positive supply voltage level) to ST pin (pin 6). If ST feature is not used pin 6 must be left floating or connected to GND. Inclination signal is provided from pin OUT.

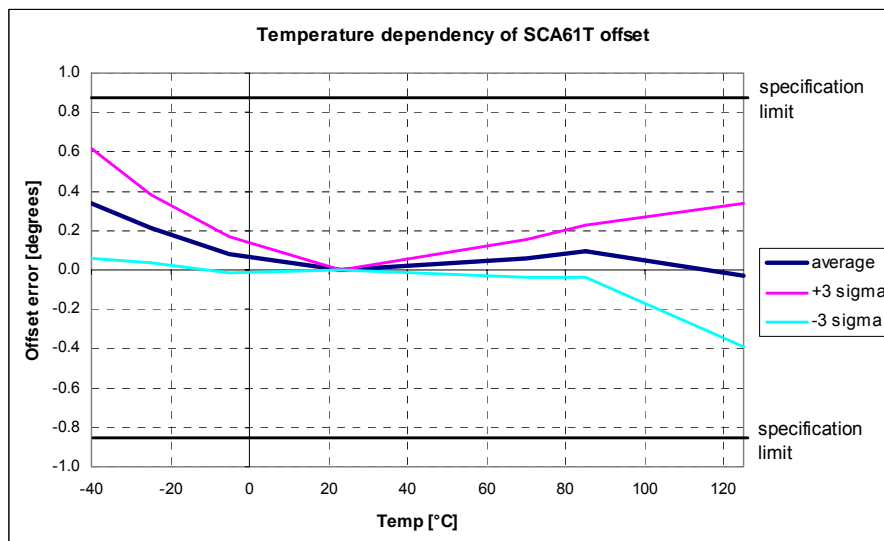


**Figure 3.** SCA61T electrical connection

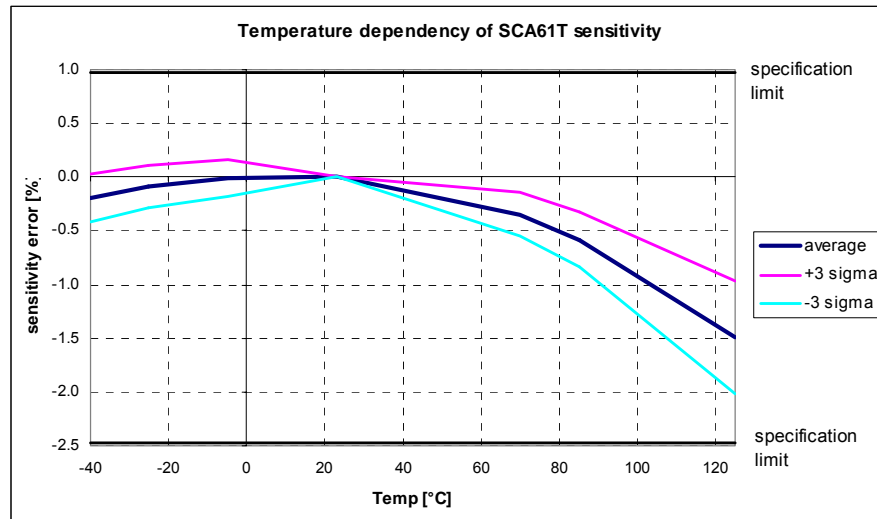
No.	Node	I/O	Description
1	SCK	Input	Serial clock
2	MISO	Output	Master in slave out; data output
3	MOSI	Input	Master out slave in; data input
4	GND	Supply	Ground
5	CSB	Input	Chip select (active low)
6	ST	Input	Self test input
7	Out	Output	Output
8	VDD	Supply	Positive supply voltage (+5V DC)

### 1.8 Typical Performance Characteristics

Typical offset and sensitivity temperature dependencies of SCA61T are presented in following diagrams. These results represent the typical performance of SCA61T components. The mean value and 3 sigma limits (mean  $\pm 3 \times$  standard deviation) and specification limits are presented in following diagrams. The 3 sigma limits represents 99.73% of the SCA61T population.



**Figure 4.** Typical temperature dependency of the SCA61T offset



**Figure 5.** Typical temperature dependency of SCA61T sensitivity

## 1.9 Additional External Compensation

To achieve the best possible accuracy, the temperature measurement information and typical temperature dependency curves can be used for SCA61T offset and sensitivity temperature dependency compensation. The equation for the fitted 3<sup>rd</sup> order polynome curve for offset compensation is:

$$Offcorr = -0.0000005 * T^3 + 0.0000857 * T^2 - 0.0032 * T + 0.0514$$

Where:

Offcorr: 3<sup>rd</sup> order polynome fitted to average offset temperature dependency curve  
T temperature in °C (Refer to paragraph 2.7 Temperature Measurement)

The calculated compensation curve can be used to compensate for the temperature dependency of the SCA61T offset by using the following equation:

$$OFFSETcomp = Offset - Offcorr$$

Where:

OFFSETcomp temperature compensated offset in degrees  
Offset Nominal offset in degrees

The equation for the fitted 2<sup>nd</sup> order polynome curve for sensitivity compensation is:

$$Scorr = -0.00011 * T^2 + 0.0019 * T + 0.0362$$

Where:

Scorr: 2<sup>nd</sup> order polynome fitted to average sensitivity temperature dependency curve  
T temperature in °C

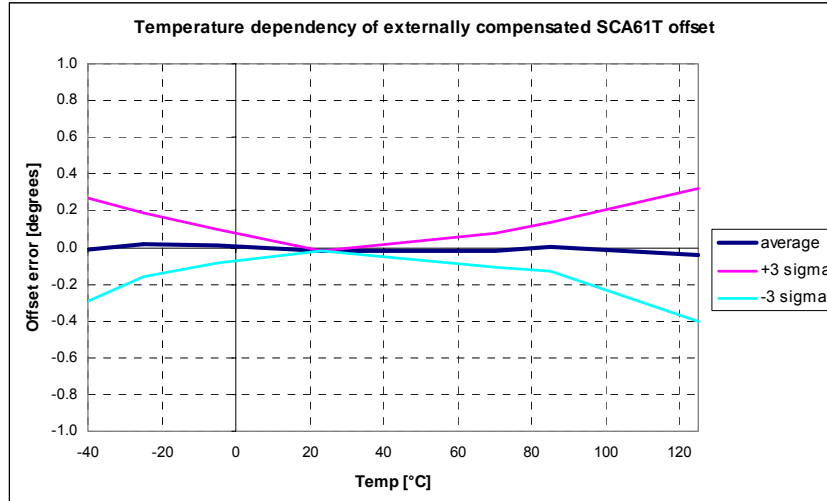
The calculated compensation curve can be used to compensate the temperature dependency of the SCA61T sensitivity by using the following equation:

$$SENScomp = SENS * (1 + Scorr / 100)$$

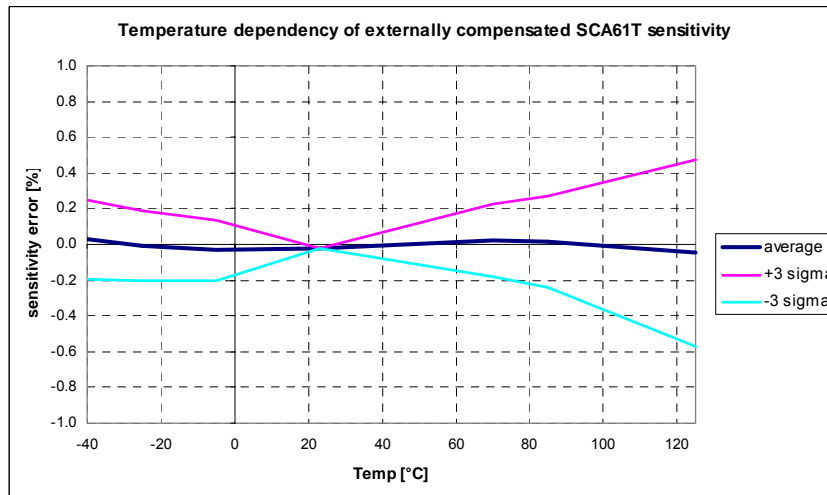
Where:

SENScomp temperature compensated sensitivity  
SENS Nominal sensitivity (4V/g SCA61T-FAHH1G, 2V/g SCA61T-FA1H1G)

The typical offset and sensitivity temperature dependency after external compensation is shown in the following diagrams.



**Figure 6.** The temperature dependency of externally compensated SCA61T offset

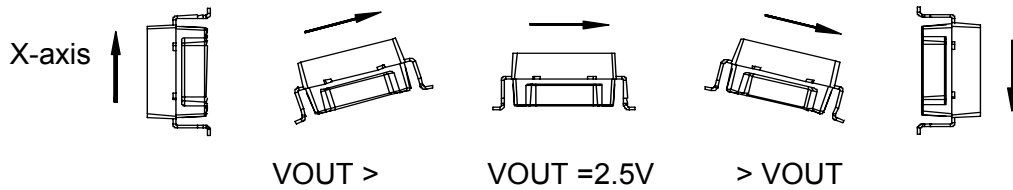


**Figure 7.** The temperature dependency of externally compensated SCA61T sensitivity



## 2 Functional Description

### 2.1 Measuring Directions



**Figure 8.** The measuring direction of the SCA61T

### 2.2 Voltage to Angle Conversion

Analog output can be transferred to angle using the following equation for conversion:

$$\alpha = \arcsin\left(\frac{V_{out} - Offset}{Sensitivity}\right)$$

where: Offset = output of the device at 0° inclination position, Sensitivity is the sensitivity of the device and  $V_{Dout}$  is the output of SCA61T. The nominal offset is 2.5 V and the sensitivity is 4 V/g with SCA61T-FAHH1G and 2 V/g with SCA61T-FA1H1G.

Angles close to 0° inclination can be estimated quite accurately with straight line conversion but for best possible accuracy arcsine conversion is recommended to be used. The following table shows the angle measurement error if straight line conversion is used.

Straight line conversion equation:

$$\alpha = \frac{V_{out} - Offset}{Sensitivity}$$

Where: Sensitivity = 70mV/° with SCA61T-FAHH1G or Sensitivity= 35mV/° with SCA61T-FA1H1G

Tilt angle [°]	Straight line conversion error [°]
0	0
1	0.0027
2	0.0058
3	0.0094
4	0.0140
5	0.0198
10	0.0787
15	0.2185
30	1.668

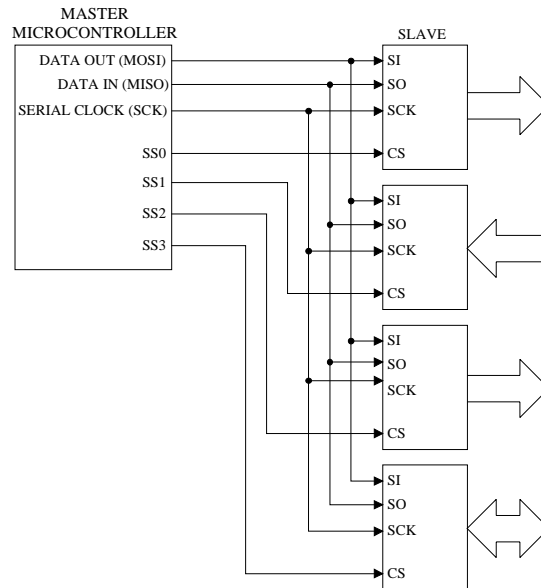
### 2.3 Ratiometric Output

Ratiometric output means that zero offset point and sensitivity of the sensor are proportional to the supply voltage. If the SCA61T supply voltage is fluctuating, the SCA61T output will also vary. When the same reference voltage for both the SCA61T sensor and the measuring part (A/D-converter) is used, the error caused by reference voltage variation is automatically compensated for.

## 2.4 SPI Serial Interface

A Serial Peripheral Interface (SPI) system consists of one master device and one or more slave devices. The master is defined as a micro controller providing the SPI clock and the slave as any integrated circuit receiving the SPI clock from the master. The ASIC in VTI Technologies' products always operates as a slave device in master-slave operation mode.

The SPI has a 4-wire synchronous serial interface. Data communication is enabled with a low active Slave Select or Chip Select wire (CSB). Data is transmitted with a 3-wire interface consisting of wires for serial data input (MOSI), serial data output (MISO) and serial clock (SCK).



**Figure 9.** Typical SPI connection

The SPI interface in VTI products is designed to support any micro controller that uses an SPI bus. Communication can be carried out by a software or hardware based SPI. Please note that in the case of a hardware based SPI, the received acceleration data is 11 bits. The data transfer uses the following 4-wire interface:

MOSI	master out slave in	$\mu\text{P} \rightarrow \text{SCA61T}$
MISO	master in slave out	$\text{SCA61T} \rightarrow \mu\text{P}$
SCK	serial clock	$\mu\text{P} \rightarrow \text{SCA61T}$
CSB	chip select (low active)	$\mu\text{P} \rightarrow \text{SCA61T}$

Each transmission starts with a falling edge of CSB and ends with the rising edge. During transmission, commands and data are controlled by SCK and CSB according to the following rules:

- commands and data are shifted; MSB first, LSB last
- each output data/status bits are shifted out on the falling edge of SCK (MISO line)
- each bit is sampled on the rising edge of SCK (MOSI line)
- after the device is selected with the falling edge of CSB, an 8-bit command is received. The command defines the operations to be performed
- the rising edge of CSB ends all data transfer and resets internal counter and command register
- if an invalid command is received, no data is shifted into the chip and the MISO remains in high impedance state until the falling edge of CSB. This reinitializes the serial communication.
- data transfer to MOSI continues immediately after receiving the command in all cases where data is to be written to SCA61T's internal registers

- data transfer out from MISO starts with the falling edge of SCK immediately after the last bit of the SPI command is sampled in on the rising edge of SCK
- maximum SPI clock frequency is 500kHz
- maximum data transfer speed for RDAX is 5300 samples per sec / channel

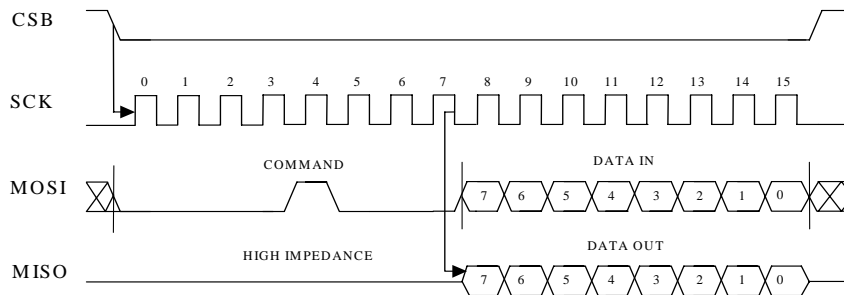
The SPI command can be either an individual command or a combination of command and data. In the case of combined command and data, the input data follows uninterruptedly the SPI command and the output data is shifted out parallel with the input data.

The SPI interface uses an 8-bit instruction (or command) register. The list of commands is given in Table below.

Command Name	Command Format	Description:
MEAS	00000000	Measure mode (normal operation mode after power on)
RWTR	00001000	Read and write temperature data register
RDSR	00001010	Read status register
RLOAD	00001011	Reload NV data to memory output register
STX	00001110	Activate Self test for X-channel
RDAX	00010000	Read X-channel acceleration through SPI

**Measure mode (MEAS)** is standard operation mode after power-up. During normal operation, the MEAS command is the exit command from Self test.

**Read temperature data register (RWTR)** reads temperature data register during normal operation without effecting the operation. Temperature data register is updated every 150  $\mu$ s. The load operation is disabled whenever the CSB signal is low, hence CSB must stay high at least 150  $\mu$ s prior the RWTR command in order to guarantee correct data. The data transfer is presented in Figure below. The data is transferred MSB first. In normal operation, it does not matter what data is written into temperature data register during the RWTR command and hence writing all zeros is recommended.

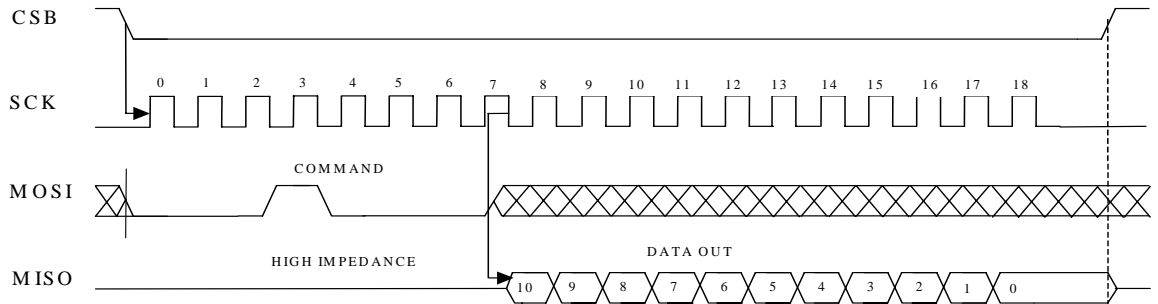


**Figure 10.** Command and 8 bit temperature data transmission over the SPI

**Self test for X-channel (STX)** activates the self test function for the X-channel (Channel 1). The Internal charge pump is activated and a high voltage is applied to the X-channel acceleration sensor element electrode. This causes the electrostatic force that deflects the beam of the sensing element and simulates the acceleration to the positive direction. The self-test is de-activated by giving the MEAS command.

**Read X-channel acceleration (RDAX)** accesses the AD converted X-channel acceleration signal stored in acceleration data register X.

During normal operation, acceleration data registers are reloaded every 150  $\mu$ s. The load operation is disabled whenever the CSB signal is low, hence CSB must stay high at least 150  $\mu$ s prior the RDAX command in order to guarantee correct data. Data output is an 11-bit digital word that is fed out MSB first and LSB last.



**Figure 11.** Command and 11 bit acceleration data transmission over the SPI

## 2.5 Digital Output to Angle Conversion

The acceleration measurement results in RDAX data register are in 11 bit digital word format. The data range is from 0 to 2048. The nominal content of RDAX data register in zero angle position is:  
Binary: 100 0000 0000  
Decimal: 1024

The transfer function from differential digital output to angle can be presented as

$$\alpha = \arcsin\left(\frac{D_{out} [\text{LSB}] - D_{out@0^\circ} [\text{LSB}]}{Sens [\text{LSB/g}]}\right)$$

where;

- $D_{out}$  digital output (RDAX)
- $D_{out@0^\circ}$  digital offset value, nominal value = 1024
- $\alpha$  angle
- $Sens$  sensitivity of the device. (SCA61T-FAHH1G: 1638, SCA61T-FA1H1G: 819)

As an example following table contains data register values and calculated differential digital output values with -5, -1 0, 1 and 5 degree tilt angles.

Angle [°]	Acceleration [mg]	RDAX (SCA61T-FAHH1G)	RDAX (SCA61T-FA1H1G)
-5	-87.16	dec: 881 bin: 011 0111 0001	dec: 953 bin: 011 1011 1001
-1	-17.45	dec: 995 bin: 011 1110 0011	dec: 1010 bin: 011 1111 0010
0	0	dec: 1024 bin: 100 0000 0000	dec: 1024 bin: 100 0000 0000
1	17.45	dec: 1053 bin: 100 0001 1101	dec: 1038 bin: 100 0000 1110
5	87.16	dec: 1167 bin: 100 1000 1111	dec: 1095 bin: 100 0100 0111

## 2.6 Self Test and Failure Detection Modes

To ensure reliable measurement results the SCA61T has continuous interconnection failure and calibration memory validity detection. A detected failure forces the output signal close to power supply ground or VDD level, outside the normal output range. The normal output ranges are: analog 0.25-4.75 V (@Vdd=5V) and SPI 102...1945 counts.

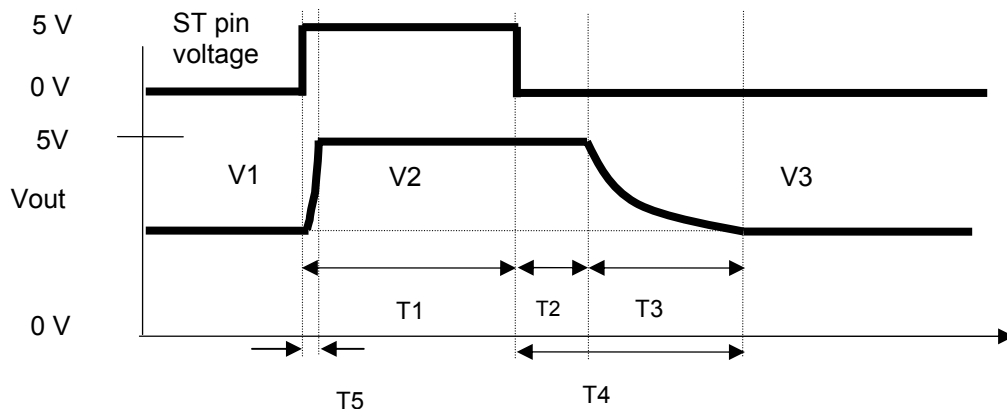
The calibration memory validity is verified by continuously running parity check for the control register memory content. In the case where a parity error is detected the control register is automatically re-loaded from the EEPROM. If a new parity error is detected after re-loading data both analog output voltage is forced to go close to ground level (<0.25 V) and SPI outputs goes below 102 counts.

The SCA61T also includes a separate self test mode. The true self test simulates acceleration, or deceleration, using an electrostatic force. The electrostatic force simulates acceleration that is high enough to deflect the proof mass to the extreme positive position, and this causes the output signal to go to the maximum value. The self test function is activated either by a separate on-off command on the self test input, or through the SPI.

The self-test generates an electrostatic force, deflecting the sensing element's proof mass, thus checking the complete signal path. The true self test performs following checks:

- Sensing element movement check
- ASIC signal path check
- PCB signal path check
- Micro controller A/D and signal path check

The created deflection can be seen in both the SPI and analogue output. The self test function is activated digitally by a STX command, and de-activated by a MEAS command. Self test can be also activated applying logic "1" (positive supply voltage level) to ST pin (pins 6) of SCA61T. The self test input high voltage level is  $4 - V_{dd} + 0.3$  V and input low voltage level is  $0.3 - 1$  V.



**Figure 12.** Self test wave forms

V1 = initial output voltage before the self test function is activated.

V2 = output voltage during the self test function.

V3 = output voltage after the self test function has been de-activated and after stabilization time. Please note that the error band specified for V3 is to guarantee that the output is within 5% of the initial value after the specified stabilization time. After a longer time (max. 1 second)  $V1 = V3$ .

T1 = Pulse length for Self test activation

T2 = Saturation delay

T3 = Recovery time

T4 = Stabilization time =  $T2 + T3$

T5 = Rise time during self test.

Self test characteristics:

T1 [ms]	T2 [ms]	T3 [ms]	T4 [ms]	T5 [ms]	V2:	V3:
20-100	Typ. 25	Typ. 30	Typ. 55	Typ. 15	Min 0.95*VDD (4.75V @Vdd=5V)	0.95*V1-1.05*V1

## 2.7 Temperature Measurement

The SCA61T has an internal temperature sensor, which is used for internal offset compensation. The temperature information is also available for additional external compensation. The temperature sensor can be accessed via the SPI interface and the temperature reading is an 8-bit word (0...255). The transfer function is expressed with the following formula:

$$T = \frac{Counts - 197}{-1.083}$$

Where:

Counts	Temperature reading
T	Temperature in °C

The temperature measurement output is not calibrated. The internal temperature compensation routine uses relative results where absolute accuracy is not needed. If the temperature measurement results are used for additional external compensation then one point calibration in the system level is needed to remove the offset. With external one point calibration the accuracy of the temperature measurement is about  $\pm 1$  °C.

### 3 Application Information

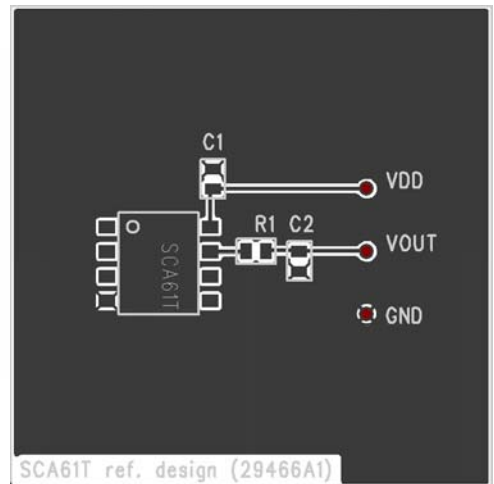
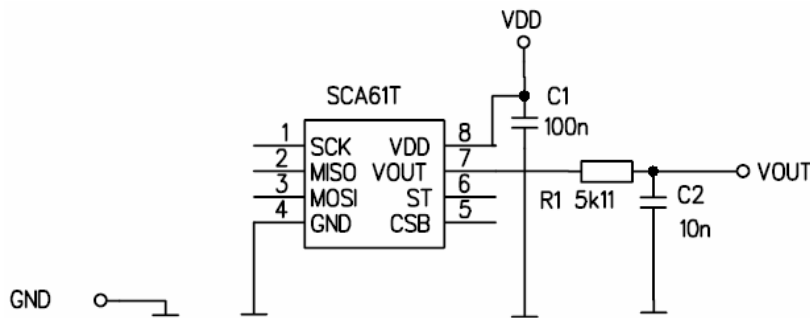
#### 3.1 Recommended Circuit Diagrams and Printed Circuit Board Layouts

The SCA61T should be powered from well regulated 5 V DC power supply. Coupling of digital noise to power supply line should be minimized. 100nF filtering capacitor between VDD pin 8 and GND plane must be used.

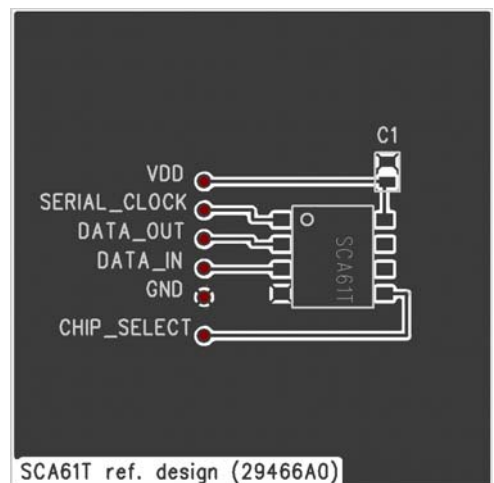
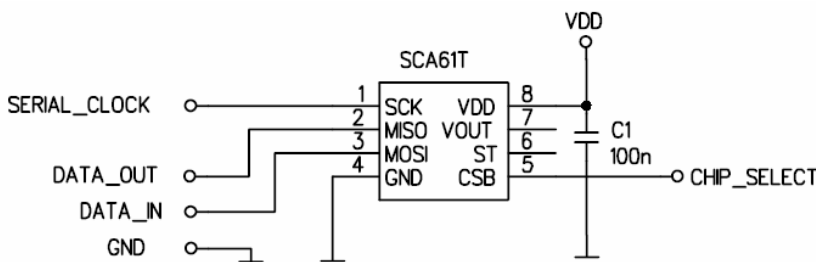
The SCA61T has ratiometric output. To get best performance use the same reference voltage for both the SCA61T and Analog/Digital converter.

Use low pass RC filter with 5.11 kΩ and 10nF on the SCA61T output to minimize clock noise.

Locate the 100nF power supply filtering capacitor close to VDD pin 8. Use as short trace length as possible. Connect the other end of capacitor directly to ground plane. Connect the GND pin 6 to underlying ground plane. Use as wide ground and power supply planes as possible. Avoid narrow power supply or GND connection strips on PCB.

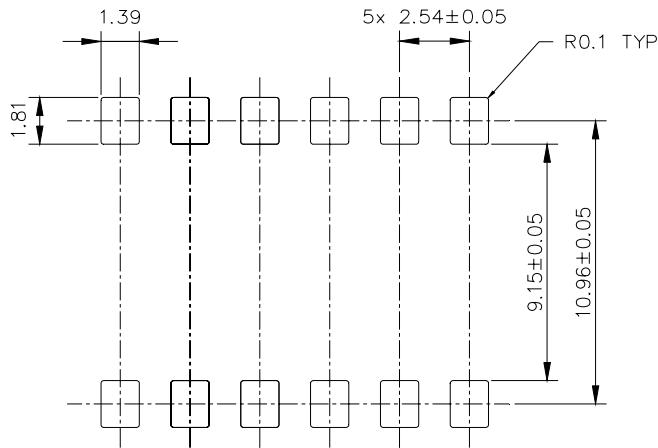


**Figure 13.** Analog connection and layout example



**Figure 14.** SPI connection example

### 3.2 Recommended Printed Circuit Board Footprint



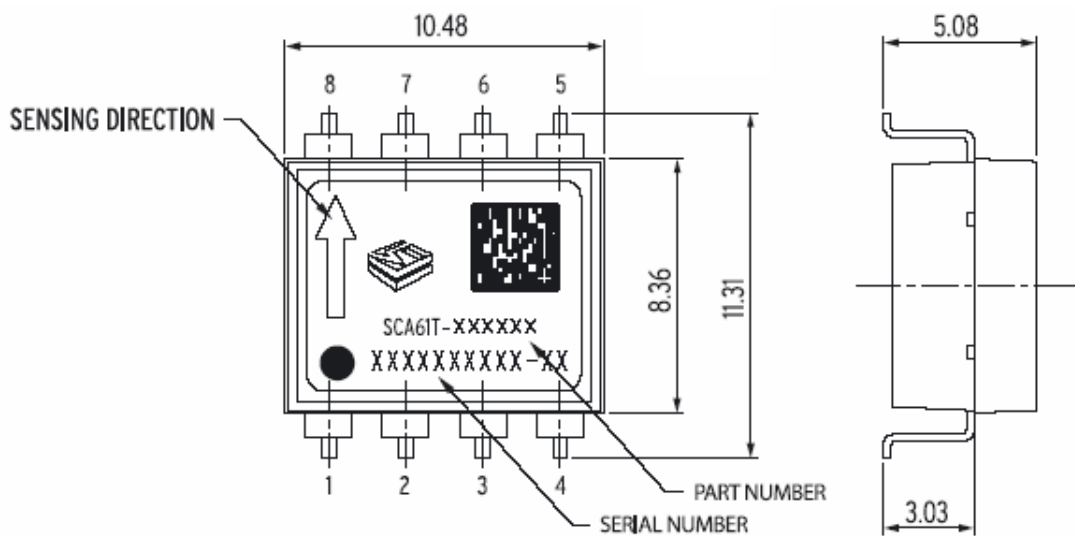
**Figure 15.** Recommended PCB footprint

## 4 Mechanical Specifications and Reflow Soldering

### 4.1 Mechanical Specifications (Reference only)

Lead frame material:  
Plating:  
Solderability:  
RoHS compliance:  
Co-planarity error  
The part weights

Copper  
Nickel followed by Gold  
JEDEC standard: JESD22-B102-C  
RoHS compliant lead free component.  
0.1mm max.  
<1 g

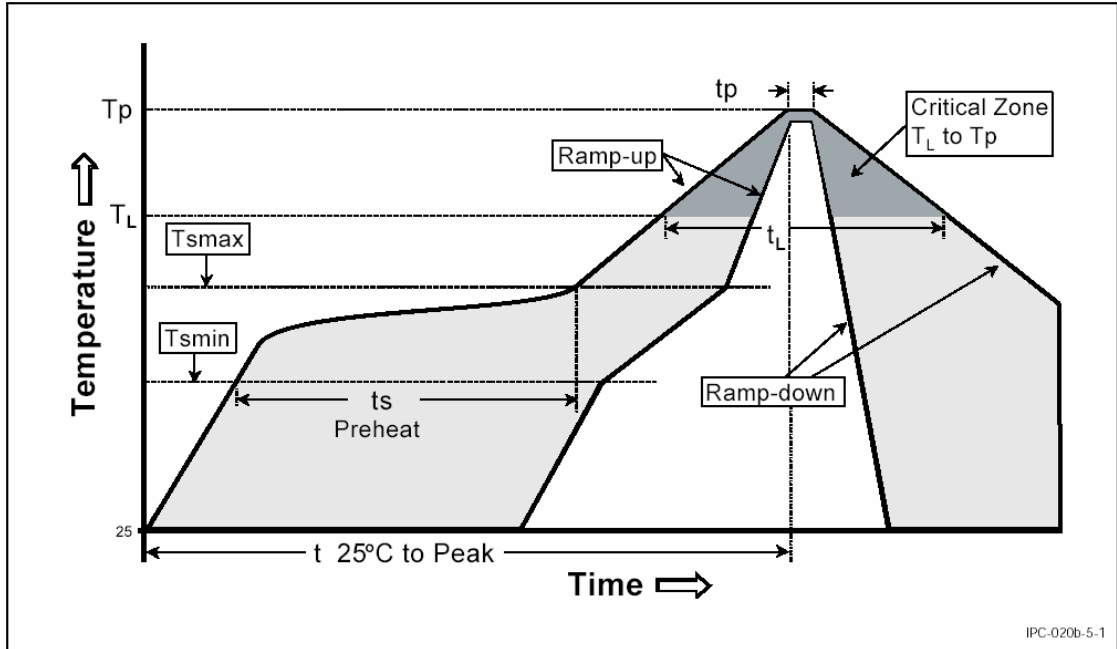


**Figure 16.** Mechanical dimensions of the SCA61T. (Dimensions in mm)



## 4.2 Reflow Soldering

The SCA61T is suitable for Sn-Pb eutectic and Pb- free soldering process and mounting with normal SMD pick-and-place equipment.



**Figure 17.** Recommended SCA61T body temperature profile during reflow soldering. Ref. IPC/JEDEC J-STD-020B.

Profile feature	Sn-Pb Eutectic Assembly	Pb-free Assembly
Average ramp-up rate ( $T_L$ to $T_P$ )	3°C/second max.	3°C/second max.
Preheat		
- Temperature min ( $T_{smin}$ )	100°C	150°C
- Temperature max ( $T_{smax}$ )	150°C	200°C
- Time (min to max) ( $t_s$ )	60-120 seconds	60-180 seconds
$T_{smax}$ to $T_P$ Ramp up rate		3°C/second max
Time maintained above:		
- Temperature ( $T_L$ )	183°C	217°C
- Time ( $t_L$ )	60-150 seconds	60-150 seconds
Peak temperature ( $T_P$ )	240 +0/-5°C	250 +0/-5°C
Time within 5°C of actual Peak Temperature ( $T_P$ )	10-30 seconds	20-40 seconds
Ramp-down rate	6°C/second max	6°C/second max
Time 25° to Peak temperature	6 minutes max	8 minutes max

The Moisture Sensitivity Level of the part is 3 according to the IPC/JEDEC J-STD-020B. The part should be delivered in a dry pack. The manufacturing floor time (out of bag) in the customer's end is 168 hours.

### Notes:

- Preheating time and temperatures according to solder paste manufacturer.
- It is important that the part is parallel to the PCB plane and that there is no angular alignment error from intended measuring direction during assembly process.
- Wave soldering is not recommended.
- **Ultrasonic cleaning is not allowed.** The sensing element may be damaged by ultrasonic cleaning process.

## 5 Document Change Control

Version	Date	Change Description
A	1.9.-06	Initial release

## 6 Contact Information

**Finland  
(head office)**  
 VTI Technologies Oy  
 P.O. Box 27  
 Myllynkivenkuja 6  
 FI-01621 Vantaa  
 Finland  
 Tel. +358 9 879 181  
 Fax +358 9 8791 8791  
 E-mail: sales@vti.fi

**Germany**  
 VTI Technologies Oy  
 Branch Office Frankfurt  
 Rennbahnstrasse 72-74  
 D-60528 Frankfurt am Main,  
 Germany  
 Tel. +49 69 6786 880  
 Fax +49 69 6786 8829  
 E-mail: sales.de@vti.fi

**USA**  
 VTI Technologies, Inc.  
 One Park Lane Blvd.  
 Suite 804 - East Tower  
 Dearborn, MI 48126  
 USA  
 Tel. +1 313 425 0850  
 Fax +1 313 425 0860  
 E-mail sales@vtitechnologies.com

**Japan**  
 VTI Technologies Oy Tokyo Office  
 Tokyo-to, Minato-ku 2-7-16  
 Bureau Toranomom  
 401105-0001  
 Japan  
 Tel. +81 3 6277 6618  
 Fax +81 3 6277 6619

**China**  
 VTI Technologies Shanghai Office  
 6th floor, Room 618  
 780 Cailun Lu  
 Pudong New Area  
 201203 Shanghai  
 P.R. China  
 Tel. +86 21 5132 0418 or  
 +86 21 5132 0400 \*112  
 Fax +86 21 513 20 416  
 E-mail: forename.surname@vti.fi

To find out your local sales representative visit [www.vti.fi](http://www.vti.fi)

VTI Technologies reserves all rights to modify this document without prior notice.