

3.3V Precision Clock Generator

Features

- No external capacitors (919 only)
- Excellent signal quality
- Very low jitter
- Precise frequencies
- Minimal undershoot, ringback or overshoot
- Nearly perfect 50% duty cycle
- Four selectable clock frequencies
- Operates at $V_{cc} = 3.3V$
- Output may be disabled to save power
- Small 150-mil wide SOIC -8 (W8) package saves board area

Pin Configuration

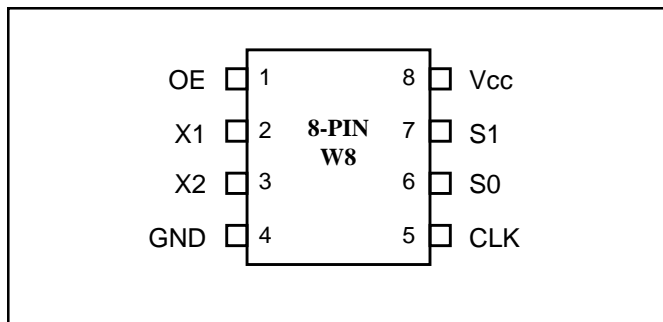

Output CLK Frequency Selection

Selection S1, S0	N/M ⁽²⁾	Clock (using 10 MHz Xtal)	Clock (using 16.6 MHz Xtal)	Clock (using 20 MHz Xtal)	Clock (using 22.1 MHz Xtal)
00	2	–	33.3 ⁽¹⁾	40	44.2
01	4	40 ⁽¹⁾	66.6 ⁽¹⁾	80 ⁽¹⁾	88.4
10	5	50 ⁽¹⁾	83	100 ⁽¹⁾	110.5
11	7	70 ⁽¹⁾	116	–	–

Notes:

1. Indicates popular target frequencies.
2. The ratio of N/M may be changed by mask option.

Description

The PI6C918 and PI6C919 are high-precision, low-voltage general-purpose clock generators that reach a maximum output frequency of 120 MHz. These devices use an external low-cost crystal to generate very accurate and stable system clocks.

These frequency synthesizers include a crystal oscillator, a programmable PLL and an output buffer. Any one of four different output frequencies can be selected via two select pins (S0, S1). The frequency multipliers are: 2, 4, 5, and 7.

The PI6C919 has on-chip capacitors, eliminating the need for external capacitors at the X1, X2 pins. This reduces overall parts count and board area, and increases reliability.

The OE (output enable) pin may be pulled down to disable the output buffer and save system power.

The small surface-mount SOIC-8 package is ideal for compact portable equipment applications.

Pin Description

Pin Name	Pin #	I/O	Description
S0	6	I	Select 0, internal pull-up
S1	7	I	Select 1, internal pull-up
X1	2	C	Crystal or clock input, 8 to 23 MHz
X2	3	C	Crystal connection or no connect
CLK	5	O	Clock output
OE	1	I	OE = 1 Enable CLK output OE = 0 Disable CLK output

Note:

1. I = Input, O = Output, C = Crystal

Product Speed Grades

Part No.	Max CLK Output Freq.	Max VCO Frequency
PI6C918/919	80 MHz	160 MHz
PI6C918A/919A	100 MHz	200 MHz
PI6C918B/919B	120 MHz	240 MHz

Maximum Ratings

Storage Temperature	-65°C to +150°C
Ambient Temperature with Power Applied	0°C to +70°C
Supply Voltage to Ground Potential (Inputs & V _{CC} Only)	-0.5V to +7.0V
Supply Voltage to Ground Potential (Outputs & D/O Only)	-0.5V to +7.0V
DC Input Voltage	-0.5V to +7.0V
DC Output Current	120 mA
Power Dissipation	0.5W

Note:

Stresses greater than those listed under MAXIMUM RATINGS may cause permanent damage to the device. This is a stress rating only and functional operation of the device at these or any other conditions above those indicated in the operational sections of this specification is not implied. Exposure to absolute maximum rating conditions for extended periods may affect reliability.

DC Electrical Characteristics

Operating Range, V_{CC} = 3.3V ±10% (918/919/918A/919A). V_{CC} = 3.3V ±5% (918B/919B), Temperature 0°C to +70°C

Symbol	Description	Test Conditions	Min.	Typ.	Max.	Units
V _{OH}	Output HIGH Voltage	V _{CC} = Min., V _{IN} = V _{IH} or V _{IL}	V _{CC} - 0.4	-	-	V
V _{OL}	Output LOW Voltage					
V _{IH}	Select Input HIGH Voltage	V _{CC} = 5V	2.0	-	-	
V _{IL}	Select Input LOW Voltage					
V _{IH}	Select Input HIGH Current	V _{CC} = Max., V _{IN} = V _{CC}	-	-	5	μA
V _{IL}	Select Input LOW Current	V _{CC} = Max., V _{IN} = 0V	-	-	-10	
I _{CC}	Supply Current	V _{CC} = Max., CLK frequency = 40 MHz	-	10	20	mA
RL	X1, X2 Negative Resistance		-1,000	-2,000	-	Ω
R _{FB}	On-chip X1, X2 Internal Feedback Resistance		227	-	-	kΩ

Note: 1. There is no guarantee that on-chip capacitance eliminates the need for external capacitors.

AC Electrical Characteristics

Operating Range, V_{CC} = 3.3V ±10% (918/919/918A/919A). V_{CC} = 3.3V ±5% (918B/919B), Temperature 0°C to +70°C

Symbol	Description	Test Conditions ⁽¹⁾	Min.	Typ.	Max.	Units
d _T	Duty Cycle,	V _{TH} = 1.4V	45	50	55	%
T _r , T _f	Rise/Fall Time	20% and 80% V _{CC}	—	—	3	ns
t _{PU}	Power-up Time ⁽²⁾		—	—	10	ms
F _{XTAL}	Crystal Input Frequency	918/918A/919/919A	10	—	20	MHz
		918B/919B	10	—	24	
T _{J1s}	One Sigma Jitter	f _{VCO} ≥60 MHz	—	—	60	ps

Note:

1. Test load of 15 pF, 2-inch trace
2. Time from when the power supply reaches 90% until locked clock output waveform is reached.

External Circuit

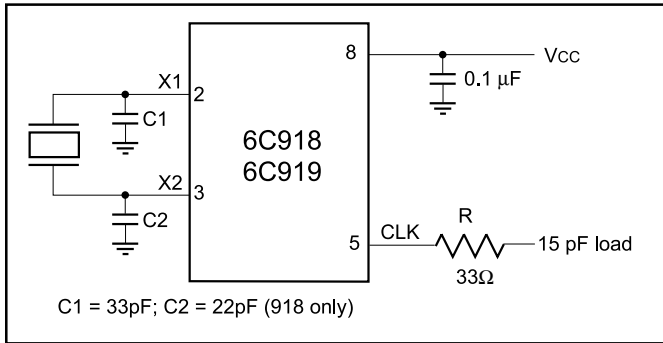

Notes:

- a. Locate crystal as close to X1, X2 pins as possible.
- b. Connect a 0.1 μF bypass capacitor at Vcc (Pin 8).

Ordering Information

Part No.	Max. Freq.	Package
PI6C918W	80MHz	Narrow SOIC-8
PI6C918AW	100MHz	
PI6C918BW	120MHz	
PI6C919W	80MHz	
PI6C919AW	100MHz	
PI6C919BW	120MHz	

Crystal Specifications

It is the customer's responsibility to procure the prototype and production crystals directly from crystal vendors.

Typical Characteristic ⁽¹⁾	Value
Frequency, F	18.43200 MHz nominal
Frequency Tolerance at 25° C	±50 ppm
Frequency Stability vs. Temperature vs. Aging	±35 ppm (0°C to 70°C) ±15 ppm/4 years
Oscillation Mode	Fundamental
Calibration Mode	Parallel resonant
Load Capacitance, C _L	20 pF, Fundamental
Shunt Capacitance, C _O	7 pF max., Fundamental
Series Resistance, R1	50Ω Typical
Drive Level	1mΩ Typical
Operating Temperature	0° to 70°C
Storage Temperature	-40° to 85°C