

Features

- Inputs and outputs operate at negative supply rail
- Unity gain bandwidth—30 MHz
- High slew rate—40 V/ μ s
- Settles to 0.01% of a 10V swing in 500 ns
- Operates with supplies as low as 3V or as great as 32V while consuming only 3.7 mA per amplifier
- Large open loop gain—110 dB
- Inputs tolerant of overload
- MIL-STD-883 Rev. C compliant

Applications

- Battery-powered instruments
- 12-bit DAC output amplifiers
- Fast-settling instrumentation amplifiers

Ordering Information

Part No.	Temp. Range	Pkg.	Outline #
EL2242CN	0°C to +75°C	8-Pin P-DIP	MDP0031
EL2242CM	0°C to +75°C	20-Lead SOL	MDP0027

General Description

The EL2242 dual monolithic operational amplifier is as flexible as prior 324 devices but offers 30 times the bandwidth and slew-rate. Its inputs and outputs are able to operate down to the negative supply and are not damaged by overloads.

The EL2242 is useable in battery-operated systems with supplies as low as 3V, yet it has excellent gain and settling times while consuming only 3.7 mA per amplifier.

Elantec's products and facilities comply with MIL-I-45208A and other applicable quality specifications. For information on Elantec's processing, see the Elantec document QRA-1: *Elantec's processing-Monolithic Products.*

Connection Diagrams

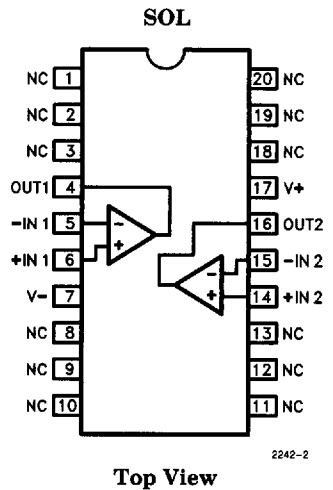
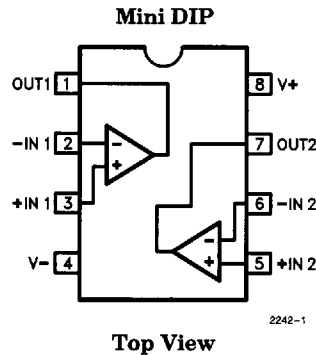

1

EL2242C

Dual Fast Single-Supply Unity-Gain Stable Op Amp

Absolute Maximum Ratings ($T_A = 25^\circ\text{C}$)

Voltage between $V+$ and $V-$	36V	Operating Junction Temperature	150°C
Voltage between $-IN$ and $+IN$ pins	36V	Storage Temperature Range	-65°C to $+150^\circ\text{C}$
Voltage at $-IN$ or $+IN$ pins	$V+$ to $V-$	Lead Temperature	
Output Current	50 mA (Peak)	DIP Package	
	30 mA (Continuous)	(Soldering, <10 seconds)	300°C
Current into $+IN$ or $-IN$	5 mA	SOL Package	
Internal Power Dissipation	See Curves	Vapor Phase (<60 seconds)	215°C
Operating Ambient Temperature Range	0°C to $+75^\circ\text{C}$	Infrared (<15 seconds)	220°C

Important Note:

All parameters having Min/Max specifications are guaranteed. The Test Level column indicates the specific device testing actually performed during production and Quality Inspection. Elantec performs most electrical tests using modern high-speed automatic test equipment, specifically the LTX77 Series system. Unless otherwise noted, all tests are pulsed tests, therefore $T_J - T_C = T_A$.

Test Level

Test Procedure

I	100% production tested and QA sample tested per QA test plan QCX0002.
II	100% production tested at $T_A = 25^\circ\text{C}$ and QA sample tested at $T_A = 25^\circ\text{C}$, T_{MAX} and T_{MIN} per QA test plan QCX0002.
III	QA sample tested per QA test plan QCX0002.
IV	Parameter is guaranteed (but not tested) by Design and Characterization Data.
V	Parameter is typical value at $T_A = 25^\circ\text{C}$ for information purposes only.

DC Electrical Characteristics

$V_S = \pm 15\text{V}$; $R_L = 1\text{k}$; $T_A = 25^\circ\text{C}$, unless otherwise specified

Parameter	Description	Temp	Min	Typ	Max	Test Level	Units
V_{OS}	Input Offset Voltage	25°C		2	7	I	mV
		Full			9	III	mV
TCV_{OS}	Average Offset Voltage Drift	Full		7		V	$\mu\text{V}/^\circ\text{C}$
I_B	Input Bias Current	25°C		0.5	1.0	I	μA
		Full			2.0	III	μA
I_{OS}	Input Offset Current	25°C		0.200	0.200	I	μA
		Full			0.300	III	μA
$R_{IN, DIFF}$	Input Differential Resistance	25°C		20		V	$\text{M}\Omega$
$R_{IN, COMM}$	Input Common-Mode Resistance	25°C		100		V	$\text{M}\Omega$
C_{IN}	Input Capacitance	25°C		2		V	pF
V_{CM+}	Positive Common-Mode Input Range	Full	12	13.3		II	V
V_{CM-}	Negative Common-Mode Input Range	Full	-15	-15.3		II	V
E_{IN}	Input Noise Voltage ($f = 1\text{ kHz}$, $R_S = 0\Omega$)	25°C		15		VV	$\text{nV}/\sqrt{\text{Hz}}$

DC Electrical Characteristics

$V_S = \pm 15V$; $R_L = 1k$; $T_A = 25^\circ C$, unless otherwise specified — Contd.

Parameter	Description	Temp	Min	Typ	Max	Test Level	Units
A_{VOL}	Large Signal Voltage Gain ($V_O = \pm 10V$)	25°C	150	300		I	V/mV
		Full	15			III	V/mV
CMRR	Common-Mode Rejection Ratio (Note 1)	Full	70	95		II	dB
PSRR	Power-Supply Rejection Ratio (Note 2)	Full	70	95		II	dB
V_O	Output Voltage Swing Negative Swing, R_L to V^- $V^+ = +5V$, $V^- = 0V$	Full	± 12	± 13.5		II	V
		Full			+20	II	mV
I_O	Output Current (Note 3)	Full	± 12	± 50	± 70	II	mA
I_S	Supply Current (Both Amplifiers)	Full		8.2	10	II	mA

AC Electrical Characteristics

$V_S = \pm 15V$; $R_L = 1k\Omega$; $C_L = 20pF$; $T_A = 25^\circ C$, unless otherwise specified

Parameter	Description	Min	Typ	Max	Test Level	Units
BW	Unity Gain -3 dB Bandwidth (Note 4)		30		V	MHz
GBW	Gain-Bandwidth Product (Note 4)		16		V	MHz
SR	Slew Rate ($V_O = \pm 10V$)		40		V	V/ μs
OS	Overshoot (Note 4)		30		V	%
t_s	Settling Time 10V Step	to 0.1%	480		V	ns
		to 0.01%	550		V	ns

Note 1: Two tests are performed with $V_{CM} = 0V$ to $-12V$ and $V_{CM} = 0V$ to $12V$.

Note 2: Two tests are performed with $V^+ = 3V$, V^- changed from $-2V$ to $-27V$; $V^- = -2V$, V^+ changed from $3V$ to $28V$.

Note 3: The inputs are overdriven by $\pm 15V$ and the output $R_L = 100\Omega$.

Note 4: $V_{IN} = 100mV$ peak-to-peak.

Test Circuit

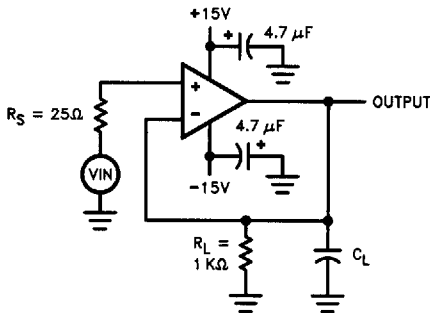

2242-3

Burn-In Circuit

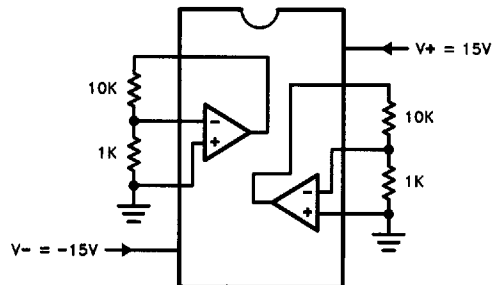

2242-4

EL2242C

Dual Fast Single-Supply Unity-Gain Stable Op Amp

Typical Performance Curves

Input Bias Current vs Common-Mode Voltage

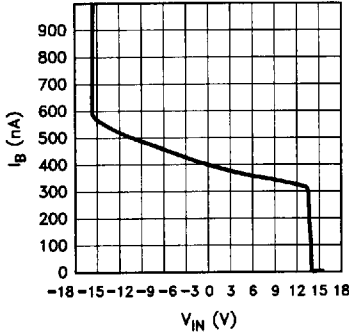

Input Bias Current vs Temperature

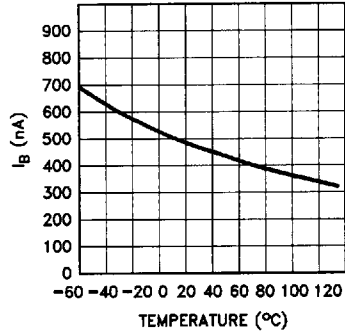

Voltage Gain vs Temperature

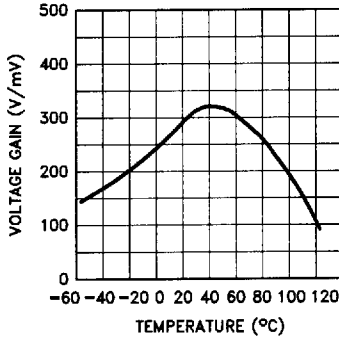

Input-Output Transfer Function, +5V Supply

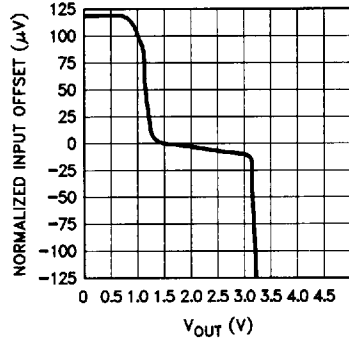

Input and Output Voltage Swings vs Supply Voltages

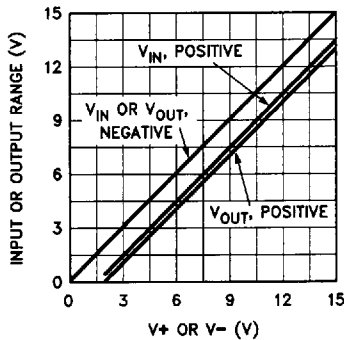

Output Voltage vs Current Sinking

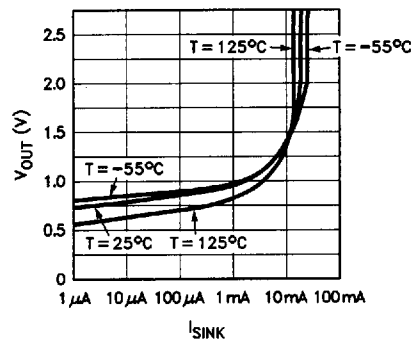

EL2242C

Dual Fast Single-Supply Unity-Gain Stable Op Amp

Typical Performance Curves — Contd.

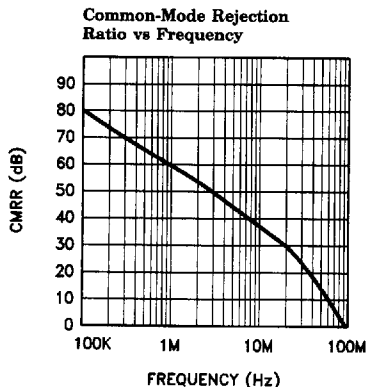
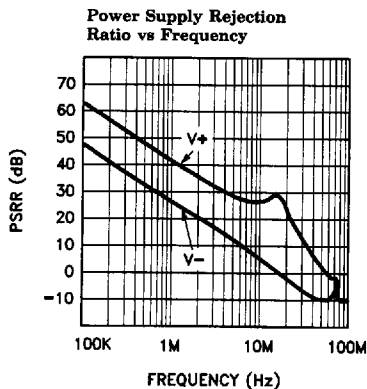
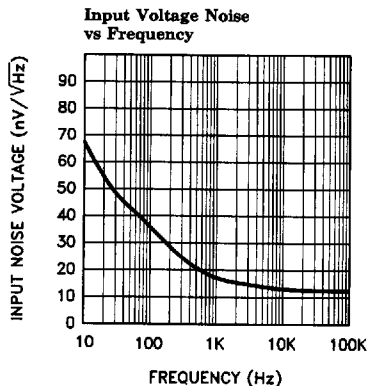
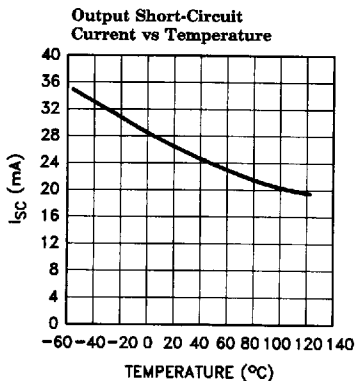
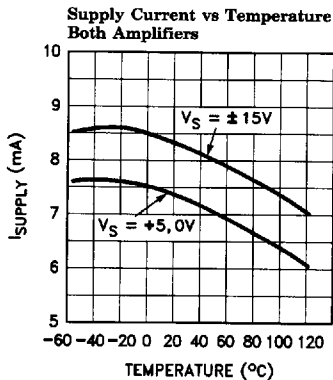
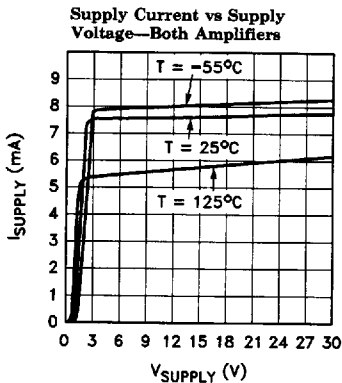

2242-6

EL2242C

Dual Fast Single-Supply Unity-Gain Stable Op Amp

Typical Performance Curves — Contd.

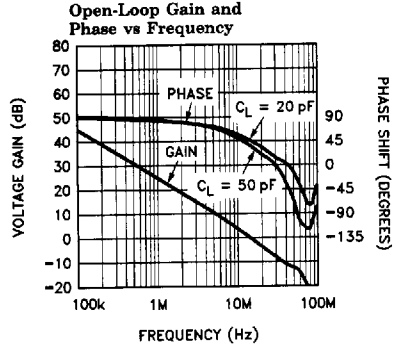
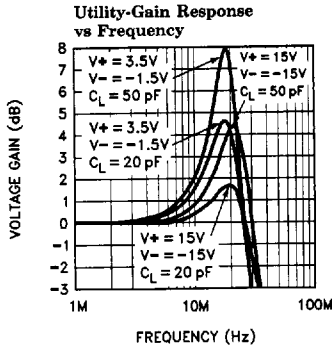

2242-7

Pulse Response with $V_+ = 3V, V_- = -2V$

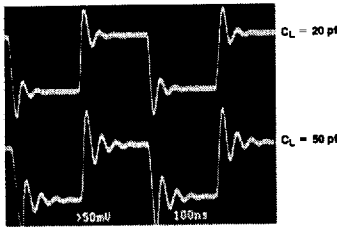

2242-8

Pulse Response with $V_+ = 15V, V_- = -15V$

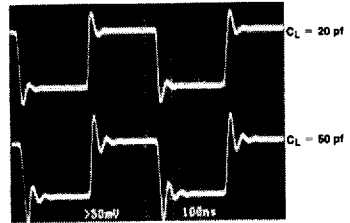

2242-9

Slew Characteristics

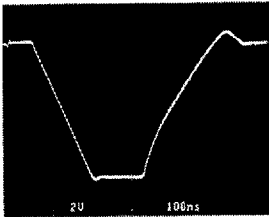

2242-10

Slew Rate vs Temperature

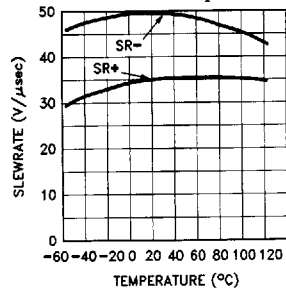

2242-11

Settling Time vs Output Swing, $V_S = \pm 15V$

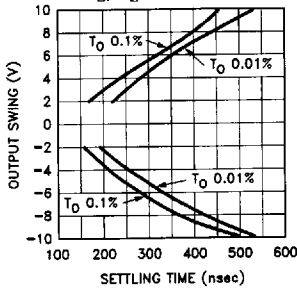

Amplifier-to-Amplifier Isolation vs Frequency

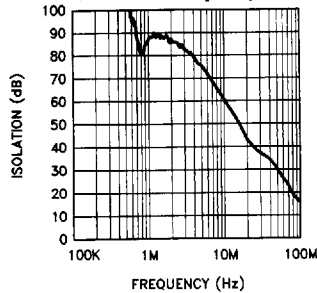

2242-12

EL2242C

Dual Fast Single-Supply Unity-Gain Stable Op Amp

EL2242C

Typical Performance Curves — Contd.

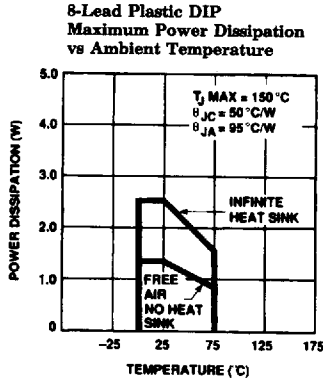

2242-13

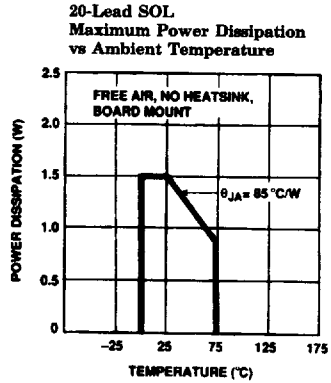

2242-15

1

Simplified Schematic (One Amplifier)

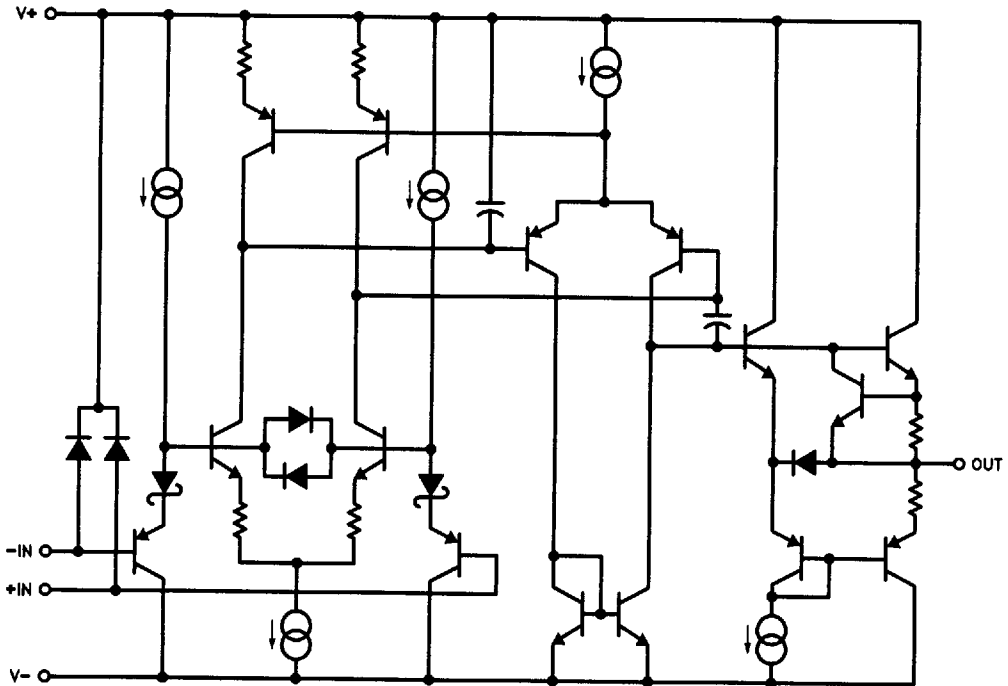

2242-16

EL2242C

Dual Fast Single-Supply Unity-Gain Stable Op Amp

Applications Information

The EL2242 is a fast amplifier designed to operate from a very wide range of power supply voltages. The inputs operate all the way to the negative supply (actually about 200 mV below it) and up to typically 2V below the positive supply. The outputs swing a similar range, but some attention is required in practice.

Specifically, while the output NPN transistor can source load current over the full output span (see the simplified schematic), the output PNP device simply turns off at negative swings below about a volt above the negative supply rail. This property is shown in the "Output Voltage vs Current-Sinking" typical curve. All single-supply amplifiers have this characteristic, and the solution is to provide a load resistor from the output to the negative supply rail.

When the output is in this extreme negative swing region, the bandwidth, gain, and settling properties are all degraded by a factor of about 2. Even so, the AC characteristics are well-behaved in this region.

Electrostatic discharge protection devices clamp the inputs a diode drop above $V+$ and a diode drop below $V-$.

As for all amplifiers, good supply bypassing will optimize settling and amplifier-to-amplifier rejection. 4.7 μF tantalum capacitors seem to be the best, and no additional small capacitor is needed in parallel for very high-frequency bypassing. Reasonably low feedback impedances are important to preserving closed-loop stability, 1k or less being acceptable when capacitive parasitics are minimized. Stability is best when the EL2242 is operated from large supplies, especially when driving capacitive loads.

EL2242C

Dual Fast Single-Supply Unity-Gain Stable Op Amp

EL2242C

EL2242 Macromodel

```
* Connections:  + input
*               |
*               | -input
*               |
*               | +Vsupply
*               | -Vsupply
*               |
*               | output
*               |
.subckt M2242  3  2  7  4  6
```

*** Input Stage**

```
ie 7 37 84uA
r6 36 37 2.1K
r7 38 37 2.1K
rc1 4 30 6K
rc2 4 39 6K
q1 30 3 36 qp
q2 39 2 38 qpa
ediff 33 0 39 30 1.0
rdiff 33 0 1Meg
```

*** Compensation Section**

```
ga 0 34 33 0 1m
rh 34 0 175Meg
ch 34 0 5pF
rc 34 40 1K
cc 40 0 7pF
```

*** Poles**

```
ep 41 0 40 0 1.0
rpa 41 42 200
cpa 42 0 4pF
rpb 42 43 1K
cpb 43 0 2pF
```

*** Output Stage**

```
ios1 7 50 1.0mA
ios2 51 4 1.0mA
q3 4 43 50 qp
q4 7 43 51 qn
q5 7 50 52 qn
q6 4 51 53 qp
ros1 52 6 25
ros2 6 53 25
```

*** Power Supply Current**

```
ips 7 4 1.8mA
```

*** Models**

```
.model qn npn(is=800E-18 bf=100 tf=0.2nS)
.model qpa pnp(is=864E-18 bf=120 tf=0.2nS)
.model qp pnp(is=800E-18 bf=50 tf=0.2nS)
.ends
```

1

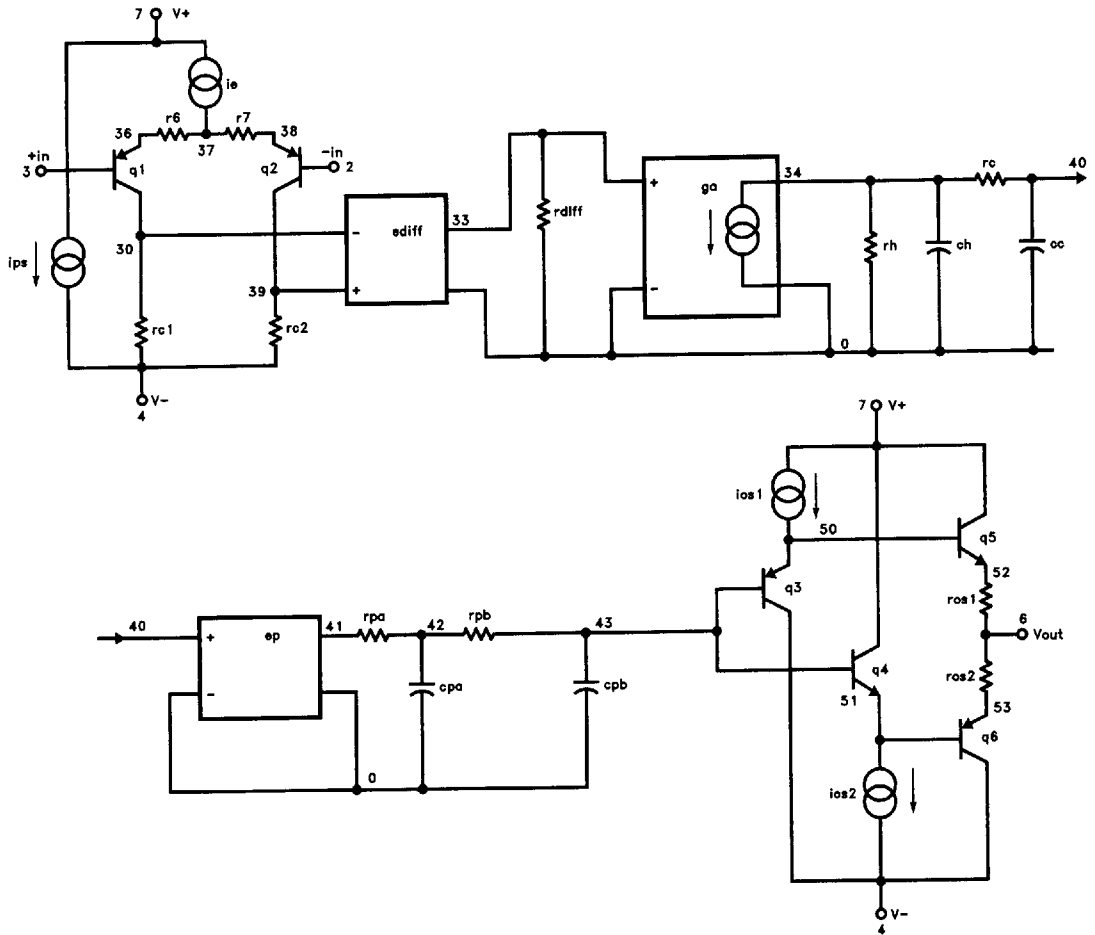
EL2242C**Dual Fast Single-Supply Unity-Gain Stable Op Amp****EL2242 Macromodel — Contd.**

2242-17