



## USB PORT TRANSIENT SUPPRESSORS

### FEATURES

- Design to Protect Submicron 3-V or 5-V Circuits from Noise Transients
- Port ESD Protection Capability Exceeds:
  - 15-kV Human Body Model
  - 2-kV Machine Model
- Available in a WCSP Chip-Scale Package
- Stand-Off Voltage . . . 6.0 V Min
- Low Current Leakage . . . 1  $\mu$ A Max at 6 V
- Low Capacitance . . . 35 pF Typ

### DESCRIPTION

The SN65220 is a single transient voltage suppressor and the SN65240 and SN75240 are dual transient voltage suppressors designed to provide electrical noise transient protection to Universal Serial Bus (USB) 1.1 ports. Note that the input capacitance of the device makes it unsuitable for high-speed USB 2.0 applications.

Any cabled I/O can be subjected to electrical noise transients from various sources. These noise transients can cause damage to the USB transceiver and/or the USB ASIC if they are of sufficient magnitude and duration.

USB ports are typically implemented in 3-V or 5-V digital CMOS with very limited ESD protection. The SN65220, SN65240, and SN75240 can significantly increase the port ESD protection level and reduce the risk of damage to the circuits of the USB port.

The IEC1000-4-2 ESD performance of the SN65220, SN65240, and SN75240 is measured at the system level. Therefore, system design impacts the results of these tests. A high compliance level may be attained with proper board design and layout.

**EQUIVALENT SCHEMATIC DIAGRAM**

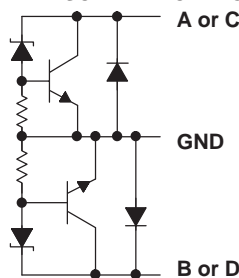

(One Suppressor Shown)

NOTE: All GND terminals should be connected to ground.

### APPLICATIONS

- USB 1.1 Host, Hub, or Peripheral Ports

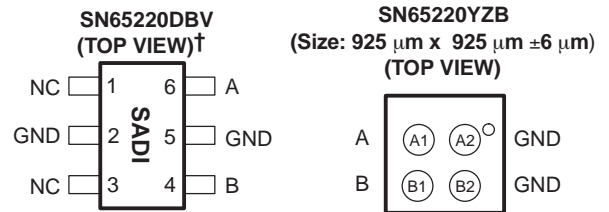

NC – No internal connection  
†When read horizontally, Pin 1 is the bottom left pin.

**SN65240P, SN65240PW  
SN75240P, SN75240PW  
(TOP VIEW)**

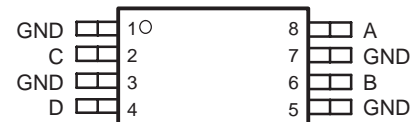

**CURRENT vs VOLTAGE**

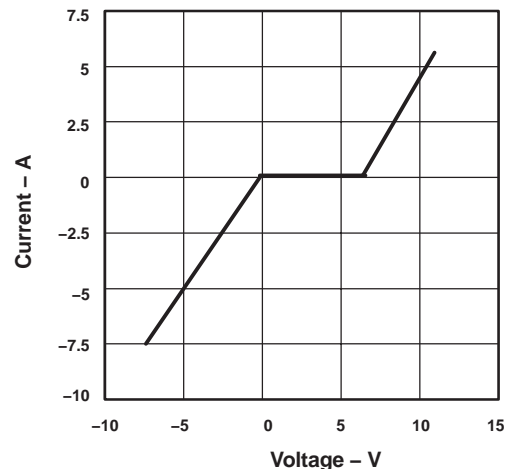

NOTE A: Typical current versus voltage curve was derived using the IEC 1.2/50- $\mu$ s surge waveform.



Please be aware that an important notice concerning availability, standard warranty, and use in critical applications of Texas Instruments semiconductor products and disclaimers thereto appears at the end of this data sheet.



This integrated circuit can be damaged by ESD. Texas Instruments recommends that all integrated circuits be handled with appropriate precautions. Failure to observe proper handling and installation procedures can cause damage.

**IEC1000-4-2 COMPLIANCE LEVEL**

IEC1000-4-2 COMPLIANCE LEVEL	MAXIMUM TEST VOLTAGE	
	CONTACT DISCHARGE (kV)	AIR DISCHARGE (kV)
1	2	2
2	4	4
3	6	8
4	8	15

**PACKAGE/ORDERING INFORMATION**

PRODUCT	SUPRESSORS	T <sub>A</sub>	PACKAGE	PACKAGE DESIGNATOR	MARKED AS	ORDER NUMBER
SN65220	1	-40°C to 85°C	WCSP-4	YZB	NWP or 65220	SN65220YZBR (Reel)
						SN65220YZBT (Mini Reel)
			SOT23-6	DBV	SADI	SN65220DBVR (Mini Reel)
						SN65220DBVT (Mini Reel)
SN65240	2	-40°C to 85°C	DIP-8	P	A65240	SN65240P (Rail)
			TSSOP-8	PW		SN65240PW (Rail)
						SN65240PWR (Reel)
SN75240	2	0°C to 70°C	DIP-8	P	A75240	SN75240P (Rail)
			TSSOP-8	PW		SN75240PW (Rail)
						SN75240PWR (Reel)

**ABSOLUTE MAXIMUM RATINGS**

over operating free-air temperature range unless otherwise noted<sup>(1)</sup>

	UNIT
Continuous power dissipation	See Dissipation Rating Table
Electrostatic discharge	15 kV <sup>(2)</sup> , 2 kV <sup>(3)</sup>
Peak power dissipation, P <sub>D(peak)</sub>	60 W
Peak forward surge current, I <sub>FSM</sub>	3 A
Peak reverse surge current, I <sub>RSM</sub>	-9 A
Storage temperature range, T <sub>stg</sub>	-65°C to 150°C

(1) Stresses above these ratings may cause permanent damage. Exposure to absolute maximum conditions for extended periods may degrade device reliability. These are stress ratings only, and functional operation of the device at these or any other conditions beyond those specified is not implied.

(2) Human Body Model – Tested in accordance with JEDEC Standard 22, Test Method A114-A.

(3) Charged Device Model – Tested in accordance with JEDEC Standard 22, Test Method C101.

DISSIPATION RATING TABLE

PACKAGE	T <sub>A</sub> ≤ 25°C POWER RATING	DERATING FACTOR ABOVE T <sub>A</sub> = 25°C‡	T <sub>A</sub> = 70°C POWER RATING	T <sub>A</sub> = 85°C POWER RATING
DBV	385 mW	3.1 mW/°C	246 mW	200 mW
P	1150 mW	9.2 mW/°C	736 mW	598 mW
PW	520 mW	4.2 mW/°C	331 mW	268 mW

‡ This is the inverse of the junction-to-ambient thermal resistance when board-mounted and with no air flow.

recommended operating conditions

		MIN	MAX	UNIT
Operating free-air temperature, T <sub>A</sub>	SN75240	0	70	°C
	SN65220, SN65240	-40	85	

electrical characteristics over recommended operating conditions (unless otherwise noted)

PARAMETER	TEST CONDITIONS	MIN	TYP	MAX	UNIT
I <sub>lkg</sub> Leakage current	V <sub>I</sub> = 6 V at A, B, C, or D terminals			1	μA
V <sub>(BR)</sub> Breakdown voltage	V <sub>I</sub> = 1 mA at A, B, C, or D terminals	6.5	7	8	V
C <sub>IN</sub> Input capacitance to ground	V <sub>I</sub> = 0.4 sin(4E6πt) + 0.5 V		35		pF

APPLICATION INFORMATION

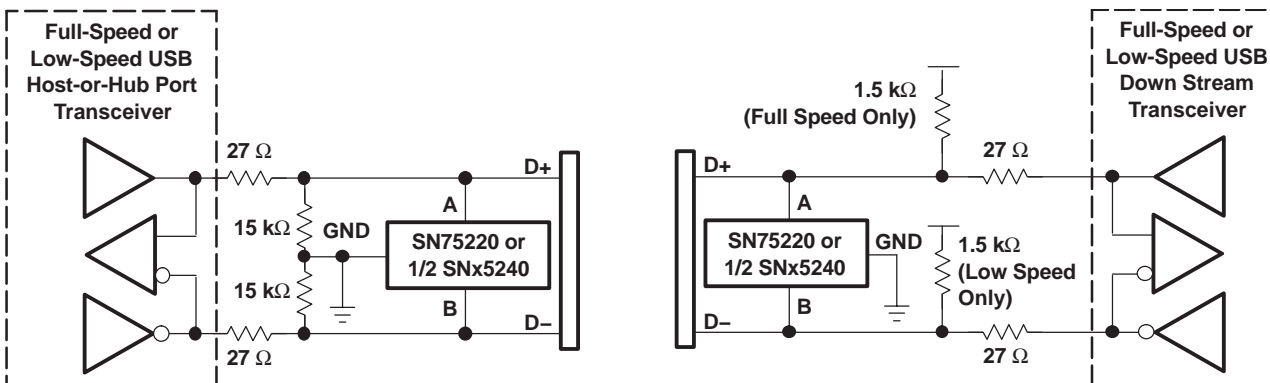

**PACKAGING INFORMATION**

Orderable Device	Status <sup>(1)</sup>	Package Type	Package Drawing	Pins	Package Qty	Eco Plan <sup>(2)</sup>	Lead/Ball Finish	MSL Peak Temp <sup>(3)</sup>
SN65220DBVR	ACTIVE	SOT-23	DBV	6	3000	Green (RoHS & no Sb/Br)	CU NIPDAU	Level-1-260C-UNLIM
SN65220DBVT	ACTIVE	SOT-23	DBV	6	250	Green (RoHS & no Sb/Br)	CU NIPDAU	Level-1-260C-UNLIM
SN65220YZBR	ACTIVE	DSBGA	YZB	4	3000	None	Call TI	Level-1-260C-UNLIM
SN65220YZBT	ACTIVE	DSBGA	YZB	4	250	None	Call TI	Level-1-260C-UNLIM
SN65240P	ACTIVE	PDIP	P	8	50	Pb-Free (RoHS)	CU NIPDAU	Level-NC-NC-NC
SN65240PW	ACTIVE	TSSOP	PW	8	150	None	CU NIPDAU	Level-1-220C-UNLIM
SN65240PWR	ACTIVE	TSSOP	PW	8	2000	None	CU NIPDAU	Level-1-220C-UNLIM
SN75240P	ACTIVE	PDIP	P	8	50	Pb-Free (RoHS)	CU NIPDAU	Level-NC-NC-NC
SN75240PW	ACTIVE	TSSOP	PW	8	150	None	CU NIPDAU	Level-1-220C-UNLIM
SN75240PWLE	OBSOLETE	TSSOP	PW	8		None	Call TI	Call TI
SN75240PWR	ACTIVE	TSSOP	PW	8	2000	None	CU NIPDAU	Level-1-220C-UNLIM
SN75240PWRG4	PREVIEW	TSSOP	PW	8	2000	None	Call TI	Call TI

<sup>(1)</sup> The marketing status values are defined as follows:

**ACTIVE:** Product device recommended for new designs.

**LIFEBUY:** TI has announced that the device will be discontinued, and a lifetime-buy period is in effect.

**NRND:** Not recommended for new designs. Device is in production to support existing customers, but TI does not recommend using this part in a new design.

**PREVIEW:** Device has been announced but is not in production. Samples may or may not be available.

**OBSOLETE:** TI has discontinued the production of the device.

<sup>(2)</sup> Eco Plan - May not be currently available - please check <http://www.ti.com/productcontent> for the latest availability information and additional product content details.

**None:** Not yet available Lead (Pb-Free).

**Pb-Free (RoHS):** TI's terms "Lead-Free" or "Pb-Free" mean semiconductor products that are compatible with the current RoHS requirements for all 6 substances, including the requirement that lead not exceed 0.1% by weight in homogeneous materials. Where designed to be soldered at high temperatures, TI Pb-Free products are suitable for use in specified lead-free processes.

**Green (RoHS & no Sb/Br):** TI defines "Green" to mean "Pb-Free" and in addition, uses package materials that do not contain halogens, including bromine (Br) or antimony (Sb) above 0.1% of total product weight.

<sup>(3)</sup> MSL, Peak Temp. -- The Moisture Sensitivity Level rating according to the JEDEC industry standard classifications, and peak solder temperature.

**Important Information and Disclaimer:** The information provided on this page represents TI's knowledge and belief as of the date that it is provided. TI bases its knowledge and belief on information provided by third parties, and makes no representation or warranty as to the accuracy of such information. Efforts are underway to better integrate information from third parties. TI has taken and continues to take reasonable steps to provide representative and accurate information but may not have conducted destructive testing or chemical analysis on incoming materials and chemicals. TI and TI suppliers consider certain information to be proprietary, and thus CAS numbers and other limited information may not be available for release.

In no event shall TI's liability arising out of such information exceed the total purchase price of the TI part(s) at issue in this document sold by TI to Customer on an annual basis.

P (R-PDIP-T8)

PLASTIC DUAL-IN-LINE



4040082/D 05/98

- NOTES: A. All linear dimensions are in inches (millimeters).  
 B. This drawing is subject to change without notice.  
 C. Falls within JEDEC MS-001

For the latest package information, go to [http://www.ti.com/sc/docs/package/pkg\\_info.htm](http://www.ti.com/sc/docs/package/pkg_info.htm)





PW (R-PDSO-G\*\*)

PLASTIC SMALL-OUTLINE PACKAGE

14 PINS SHOWN



4040064/F 01/97

- NOTES: A. All linear dimensions are in millimeters.  
 B. This drawing is subject to change without notice.  
 C. Body dimensions do not include mold flash or protrusion not to exceed 0,15.  
 D. Falls within JEDEC MO-153

YZB (S-XBGA-N4)

DIE-SIZE BALL GRID ARRAY

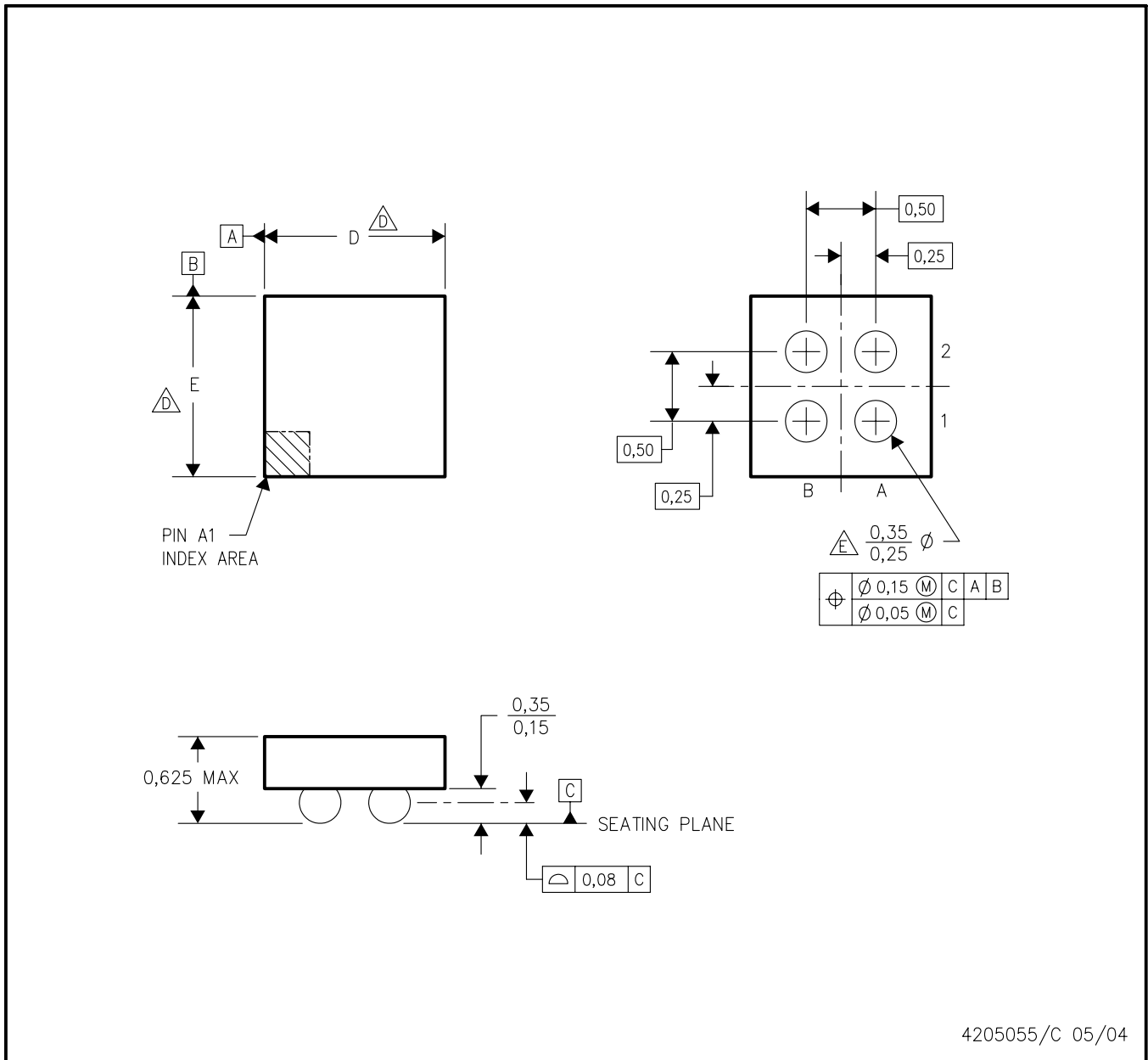

- NOTES:
- A. All linear dimensions are in millimeters.
  - B. This drawing is subject to change without notice.
  - C. NanoFree™ package configuration.
  - $\triangle D$  Devices in YZB package can have dimension D ranging from 0.85 to 1.65 mm and dimension E ranging from 0.85 to 1.65 mm. To determine the exact package size of a particular device, refer to the device datasheet or contact a local TI representative.
  - $\triangle E$  Reference Product Data Sheet for array population.  
2 x 2 matrix is shown for illustration only.
  - F. This package contains lead-free balls.  
Refer to YEB (Drawing #4204178) for tin-lead (SnPb) balls.



## IMPORTANT NOTICE

Texas Instruments Incorporated and its subsidiaries (TI) reserve the right to make corrections, modifications, enhancements, improvements, and other changes to its products and services at any time and to discontinue any product or service without notice. Customers should obtain the latest relevant information before placing orders and should verify that such information is current and complete. All products are sold subject to TI's terms and conditions of sale supplied at the time of order acknowledgment.

TI warrants performance of its hardware products to the specifications applicable at the time of sale in accordance with TI's standard warranty. Testing and other quality control techniques are used to the extent TI deems necessary to support this warranty. Except where mandated by government requirements, testing of all parameters of each product is not necessarily performed.

TI assumes no liability for applications assistance or customer product design. Customers are responsible for their products and applications using TI components. To minimize the risks associated with customer products and applications, customers should provide adequate design and operating safeguards.

TI does not warrant or represent that any license, either express or implied, is granted under any TI patent right, copyright, mask work right, or other TI intellectual property right relating to any combination, machine, or process in which TI products or services are used. Information published by TI regarding third-party products or services does not constitute a license from TI to use such products or services or a warranty or endorsement thereof. Use of such information may require a license from a third party under the patents or other intellectual property of the third party, or a license from TI under the patents or other intellectual property of TI.

Reproduction of information in TI data books or data sheets is permissible only if reproduction is without alteration and is accompanied by all associated warranties, conditions, limitations, and notices. Reproduction of this information with alteration is an unfair and deceptive business practice. TI is not responsible or liable for such altered documentation.

Resale of TI products or services with statements different from or beyond the parameters stated by TI for that product or service voids all express and any implied warranties for the associated TI product or service and is an unfair and deceptive business practice. TI is not responsible or liable for any such statements.

Following are URLs where you can obtain information on other Texas Instruments products and application solutions:

<b>Products</b>		<b>Applications</b>	
Amplifiers	<a href="http://amplifier.ti.com">amplifier.ti.com</a>	Audio	<a href="http://www.ti.com/audio">www.ti.com/audio</a>
Data Converters	<a href="http://dataconverter.ti.com">dataconverter.ti.com</a>	Automotive	<a href="http://www.ti.com/automotive">www.ti.com/automotive</a>
DSP	<a href="http://dsp.ti.com">dsp.ti.com</a>	Broadband	<a href="http://www.ti.com/broadband">www.ti.com/broadband</a>
Interface	<a href="http://interface.ti.com">interface.ti.com</a>	Digital Control	<a href="http://www.ti.com/digitalcontrol">www.ti.com/digitalcontrol</a>
Logic	<a href="http://logic.ti.com">logic.ti.com</a>	Military	<a href="http://www.ti.com/military">www.ti.com/military</a>
Power Mgmt	<a href="http://power.ti.com">power.ti.com</a>	Optical Networking	<a href="http://www.ti.com/opticalnetwork">www.ti.com/opticalnetwork</a>
Microcontrollers	<a href="http://microcontroller.ti.com">microcontroller.ti.com</a>	Security	<a href="http://www.ti.com/security">www.ti.com/security</a>
		Telephony	<a href="http://www.ti.com/telephony">www.ti.com/telephony</a>
		Video & Imaging	<a href="http://www.ti.com/video">www.ti.com/video</a>
		Wireless	<a href="http://www.ti.com/wireless">www.ti.com/wireless</a>

Mailing Address: Texas Instruments  
Post Office Box 655303 Dallas, Texas 75265

This datasheet has been download from:

[www.datasheetcatalog.com](http://www.datasheetcatalog.com)

Datasheets for electronics components.